

Introduction to Machine Guarding

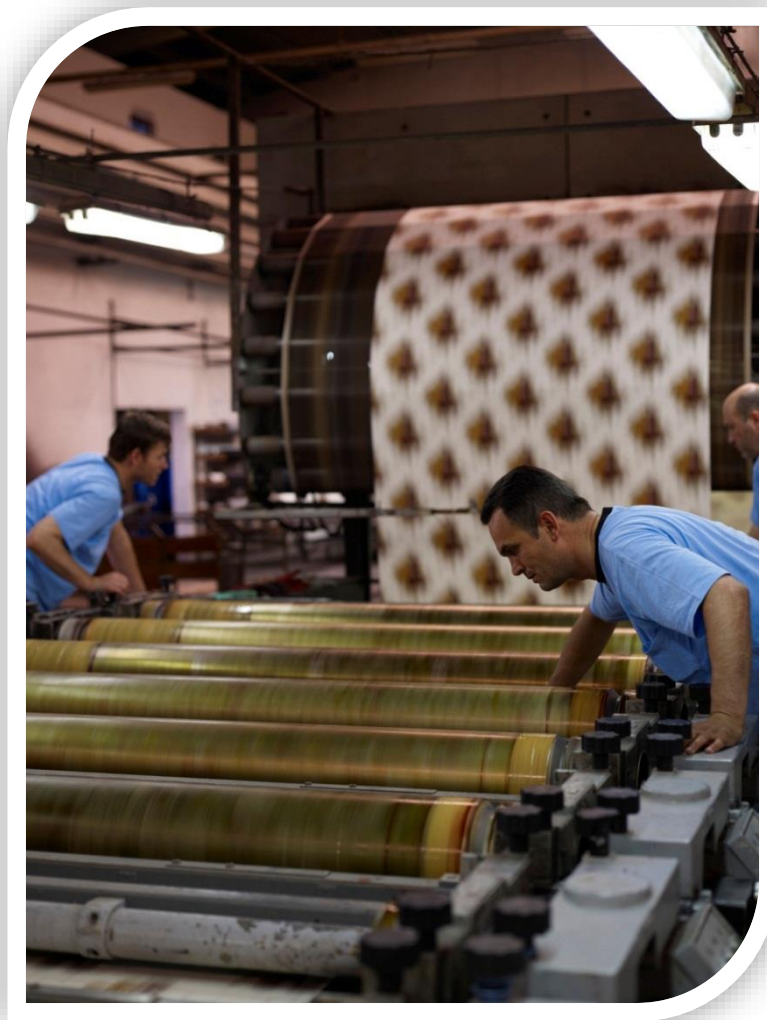

This page intentionally blank

OSHAcademy Course 726 Study Guide

Introduction to Machine Guarding

Copyright © 2015 Geigle Safety Group, Inc.

No portion of this text may be reprinted for other than personal use. Any commercial use of this document is strictly forbidden.

Contact OSHAcademy to arrange for use as a training document.

This study guide is designed to be reviewed off-line as a tool for preparation to successfully complete OSHAcademy Course 726.

Read each module, answer the quiz questions, and submit the quiz questions online through the course webpage. You can print the post-quiz response screen which will contain the correct answers to the questions.

The final exam will consist of questions developed from the course content and module quizzes.

We hope you enjoy the course and if you have any questions, feel free to email or call:

OSHAcademy

1915 NW Amberglen Parkway, Suite 400

Beaverton, Oregon 97006

www.oshatrain.org

instructor@oshatrain.org

+1 (888) 668-9079

Disclaimer

This document does not constitute legal advice. Consult with your own company counsel for advice on compliance with all applicable state and federal regulations. Neither Geigle Safety Group, Inc., nor any of its employees, subcontractors, consultants, committees, or other assignees make any warranty or representation, either express or implied, with respect to the accuracy, completeness, or usefulness of the information contained herein, or assume any liability or responsibility for any use, or the results of such use, of any information or process disclosed in this publication. GEIGLE SAFETY GROUP, INC., DISCLAIMS ALL OTHER WARRANTIES EXPRESS OR IMPLIED INCLUDING, WITHOUT LIMITATION, ANY WARRANTIES OF MERCHANTABILITY OR FITNESS FOR A PARTICULAR PURPOSE. Taking actions suggested in this document does not guarantee that an employer, employee, operator or contractor will be in compliance with applicable regulations. Ultimately every company is responsible for determining the applicability of the information in this document to its own operations. Each employer's safety management system will be different. Mapping safety and environmental management policies, procedures, or operations using this document does not guarantee compliance regulatory requirements.

This page intentionally blank

Contents

Introduction	1
The Purpose for machine guarding.....	1
Module 1: The Basics of Machine Guarding	2
Where Mechanical Hazards Occur.....	2
Hazardous Mechanical Motions and Actions	2
Motions.....	3
Actions	6
Requirements for Safeguards	8
Non-Mechanical Hazards	9
Training	11
Protective Clothing and Personal Protective Equipment	11
Module 1 Quiz.....	13
Module 2: Methods of Machine Safeguarding - Guards	15
Introduction	15
The Five General Classifications of Safeguards.....	15
Guards.....	17
Fixed Guards	17
Interlocked Guards.....	18
Adjustable Guards.....	19
Self-Adjusting Guards.....	21
Module 2 Quiz.....	22
Module 3: Methods of Machine Safeguarding - Devices	24
Introduction	24

Presence-Sensing Devices	24
Pullback Devices.....	26
Restraint Devices	27
Safety Trip Controls.....	28
Two-Hand Control Devices	29
Two-Hand Trip Devices	30
Module 3 Quiz.....	31
Module 4: More Safeguarding Methods	33
Safeguarding by Location and Distance.....	33
Feeding the Ejection Methods.....	34
Automatic Feed Systems.....	34
Semi-Automatic Feeding Systems	35
Semi-Automatic Ejection Systems	36
Robot Systems	37
Miscellaneous Aids.....	40
Module 4 Quiz.....	43
Module 5: Machine Guard Construction	45
Guard Construction.....	45
Advantages of Builder-Designed Guards	45
Advantages of User-Built Guards.....	45
Disadvantages of User-Built Guards	45
Point-of-Operation Guards	46
Mechanical Power Transmission Apparatus Guarding.....	46
Guard Material.....	46

Module 5 Quiz.....	47
Module 6: Machinery Maintenance and Repair.....	48
Machinery Maintenance and Repair	48
Hazard Identification and Reporting.....	48
Machine Guard Design Considerations	48
Sources of Hazardous Energy during Maintenance and Repair	49
Electrical Energy Hazards.....	49
Mechanical Energy Hazards.....	49
Pneumatic and Hydraulic Energy Hazards	50
Performing Lockout/Tagout (LOTO) Procedures	50
Release from Lockout/Tagout Procedures	51
Scenario: Mine Fatality	52
Module 6 Quiz.....	54

This page intentionally blank

Introduction

The Purpose for machine guarding

Unguarded machinery claims far too many limbs and lives from workers around the world. Such tragedies can be avoided by better training for machine operators, and most importantly, by making machines in the workplace safer.



This course examines dozens of possible ways to safeguard machinery.

This course has been prepared as an aid to employers, employees, machine manufacturers, machine guard designers and fabricators, and all others with an interest in protecting workers against the hazards of moving machine parts. It identifies the major mechanical motions and the general principles of safeguarding them.

Current applications of each technique are shown in accompanying illustrations of specific operations and machines. The methods described here may be transferred, with due care, to different machines with similar hazards. To determine whether or not safeguarding meets the requirements of the standard, any mechanical motion that threatens a worker's safety should not remain unguarded.

The approaches to machine safeguarding discussed in this course are not the only solutions which meet the requirements of the OSHA Machine Guarding standard. Why? Because practical solutions to safeguarding moving machine parts are as numerous as the people working on them. No course or publication could keep pace with all of these solutions or attempt to depict them all.

In machine safeguarding, as in other regulated areas of the American workplace, to a certain extent OSHA standards govern function and practice. This course, however, is not a substitute for the standards. It provides basic technical information and workable ideas which the employer may use as a guide to achieve compliance. It offers an overview of the machine safeguarding problem in the industrial setting, an assortment of solutions in popular use, and a challenge to all whose work involves machines.

Module 1: The Basics of Machine Guarding

Crushed hands and arms, severed fingers, blindness -- the list of possible machinery-related injuries is as long as it is horrifying. There seem to be as many hazards created by moving machine parts as there are types of machines. Safeguards are essential for protecting workers from needless and preventable injuries.

A good rule to remember is: **Any machine part, function, or process which may cause injury must be safeguarded.** When the operation of a machine or accidental contact with it can injure the operator or others in the vicinity, the hazards must be either controlled or eliminated.



This course describes the various hazards of mechanical motion and presents some techniques for protecting workers from these hazards. General information covered in this chapter includes -- where mechanical hazards occur, the hazards created by different kinds of motions and the requirements for effective safeguards, as well as a brief discussion of non-mechanical hazards.

Where Mechanical Hazards Occur

Dangerous moving parts in three basic areas require safeguarding:

The point of operation: that point where work is performed on the material, such as cutting, shaping, boring, or forming of stock.

Power transmission apparatus: all components of the mechanical system which transmit energy to the part of the machine performing the work. These components include flywheels, pulleys, belts, connecting rods, couplings, cams, spindles, chains, cranks, and gears.

Other moving parts: all parts of the machine which moves while the machine is working. These can include reciprocating, rotating, and transverse moving parts, as well as feed mechanisms and auxiliary parts of the machine.

Hazardous Mechanical Motions and Actions

A wide variety of mechanical motions and actions may present hazards to the worker. These can include the movement of rotating members, reciprocating arms, moving belts, meshing gears, cutting teeth, and any parts that impact or shear. These different types of hazardous

mechanical motions and actions are basic in varying combinations to nearly all machines, and recognizing them is the first step toward protecting workers from the danger they present.

The basic types of hazardous mechanical motions and actions are:

Motions

- rotating (including in-running nip points)
- reciprocating
- transversing

Actions

- cutting
- punching
- shearing
- bending

Motions

Rotating motion can be dangerous; even smooth, slowly rotating shafts can grip clothing, and through mere skin contact force an arm or hand into a dangerous position. Injuries due to contact with rotating parts can be severe.

Collars, couplings, cams, clutches, flywheels, shaft ends, spindles, meshing gears, and horizontal or vertical shafting are some examples of common rotating mechanisms which may be hazardous. The danger increases when projections such as set screws, bolts, nicks, abrasions, and projecting keys or set screws are exposed on rotating parts, as shown in Figure below.

In-running nip point hazards are caused by the rotating parts on machinery. There are three main types of in-running nips.

Parts can rotate in opposite directions while their axes are parallel to each

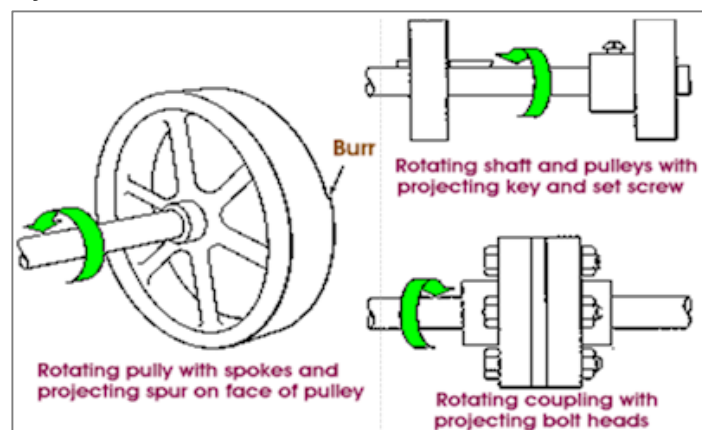

other. These parts may be in contact (producing a “nip point”) or in close proximity. In the latter case the stock fed between the rolls produces the nip points. This danger is common on machines with intermeshing gears, rolling mills, and calendars. See the figure below.

Parts rotating in opposite direction

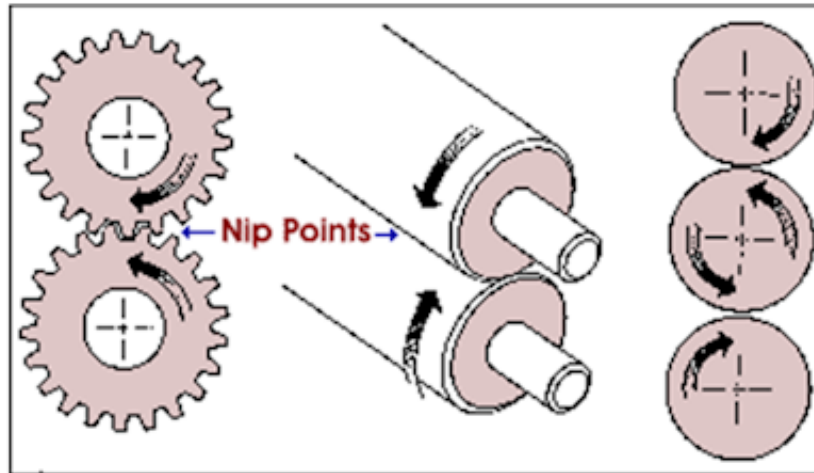

Rotating and tangentially moving parts

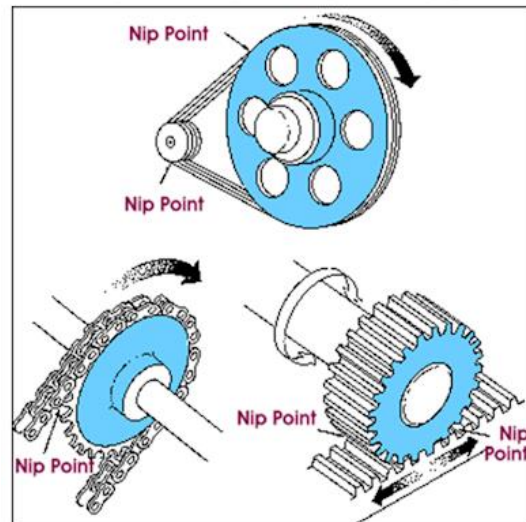

Nip points are also created between rotating and tangentially moving parts. Some examples would be: the point of contact between a power transmission belt and its pulley, a chain and a sprocket, and a rack and pinion. See Figure Right.

Nip points can occur between rotating and fixed parts which create a shearing, crushing, or abrading action. Examples are: spoked-handwheels or flywheels, screw conveyors, or the periphery of an abrasive wheel and an incorrectly adjusted work rest. See Figure below.

Rotating and fixed parts

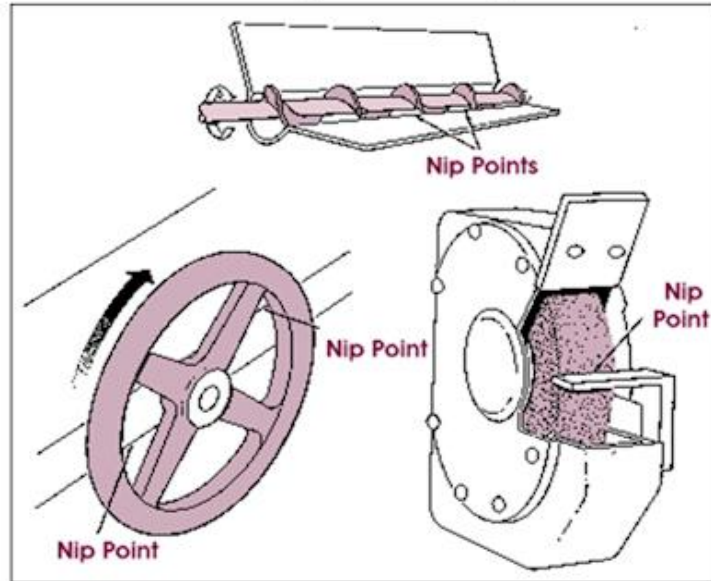

Reciprocating motions may be hazardous because, during the back-and-forth or up-and-down motion, a worker may be struck by or caught between a moving and a stationary part. See the figure to the right for an example of a reciprocating motion.

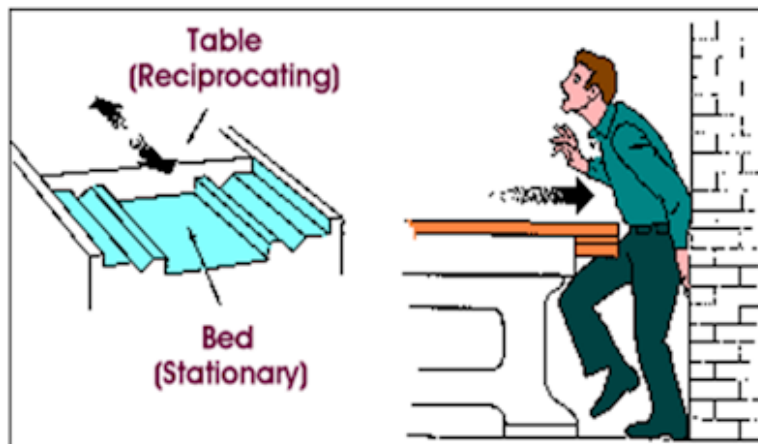

Transverse motion (movement in a straight, continuous line) creates a hazard because a worker may be struck or caught in a **pinch or shear point** by the moving part. See figure to the right.

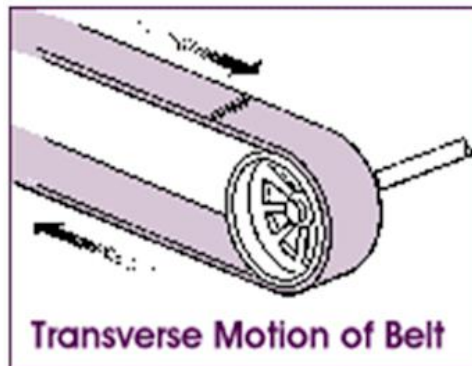

Actions

Cutting action may involve rotating, reciprocating, or transverse motion. The danger of cutting action exists at the point of operation where finger, arm and body injuries can occur and where flying chips or scrap material can strike the head, particularly in the area of the eyes or face. Such hazards are present at the point of operation in cutting wood, metal, or other materials.

Examples of mechanisms involving cutting hazards include band saws, circular saws, boring or drilling machines, turning machines (lathes), or milling machines. See Figure below.

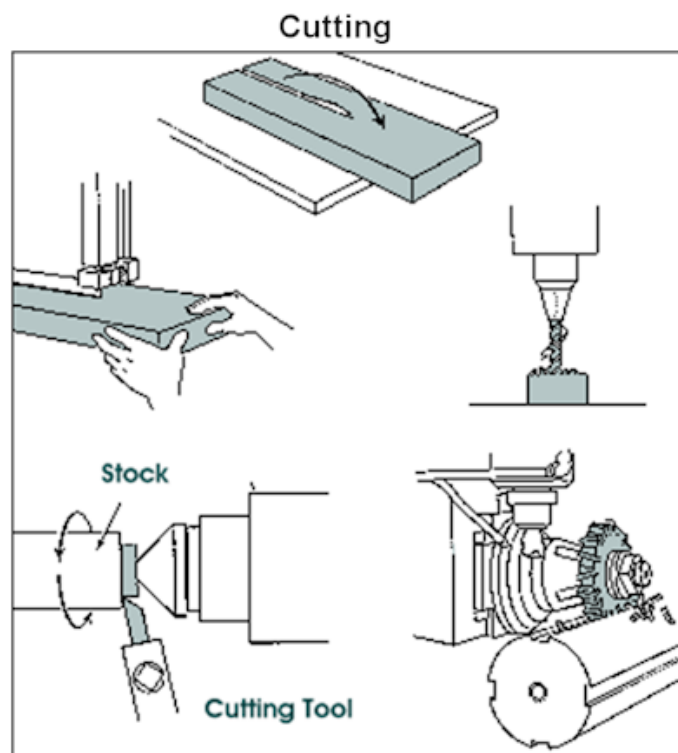

Punching action happens when power is applied to a slide (ram) for the purpose of blanking, drawing, or stamping metal or other materials. The danger of this type of action occurs at the point of operation where stock is inserted, held, and withdrawn by hand.

Typical machines used for punching operations are power presses and iron workers. See Figure below.

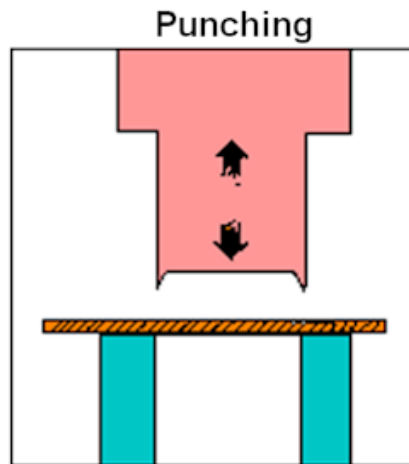

Shearing action involves applying power to a slide or knife in order to trim or shear metal or other materials. A hazard occurs at the point of operation where stock is actually inserted, held, and withdrawn.

Examples of machines used for shearing operations are mechanically, hydraulically, or pneumatically powered shears. See Figure below.

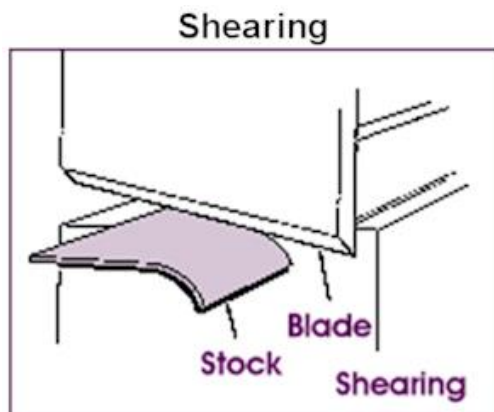

Bending action results when power is applied to a slide in order to draw or stamp metal or other materials. A hazard occurs at the point of operation where stock is inserted, held, and withdrawn.

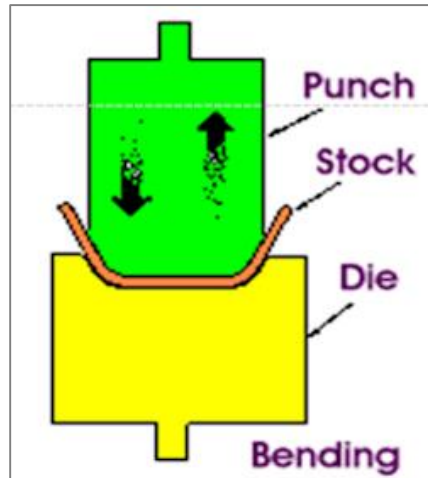

Equipment that uses bending action includes power presses, press brakes, and tubing benders. See Figure above.

Requirements for Safeguards

What must a safeguard do to protect workers against mechanical hazards? Safeguards must meet these minimum general requirements:

Prevent contact: The safeguard must prevent hands, arms, and any other part of a worker's body from making contact with dangerous moving parts. A good safeguarding system eliminates the possibility of the operator or another worker placing parts of their bodies near hazardous moving parts.

Secure: Workers should not be able to easily remove or tamper with the safeguard, because a safeguard that can easily be made ineffective is no safeguard at all. Guards and safety devices should be made of durable material that will withstand the conditions of normal use. They must be firmly secured to the machine.

Protect from falling objects: The safeguard should ensure that no objects can fall into moving parts. A small tool which is dropped into a cycling machine could easily become a projectile that could strike and injure someone.

Create no new hazards: A safeguard defeats its own purpose if it creates a hazard of its own such as a shear point, a jagged edge, or an unfinished surface which can cause a

laceration. The edges of guards, for instance, should be rolled or bolted in such a way that they eliminate sharp edges.

Create no interference: Any safeguard which impedes a worker from performing the job quickly and comfortably might soon be overridden or disregarded. Proper safeguarding can actually enhance efficiency since it can relieve the worker's apprehensions about injury.

Allow safe lubrication: If possible, one should be able to lubricate the machine without removing the safeguards. Locating oil reservoirs outside the guard, with a line leading to the lubrication point, will reduce the need for the operator or maintenance worker to enter the hazardous area.

Non-Mechanical Hazards

While this course concentrates attention on concepts and techniques for safeguarding mechanical motion, machines obviously present a variety of other hazards which cannot be ignored. Full discussion of these matters is beyond the scope of this course, but some non-mechanical hazards are briefly mentioned below to remind you of things other than safeguarding moving parts that can affect the safe operation of machines.

All power sources for machines are potential sources of danger.

When using electrically powered or controlled machines, for instance, the equipment as well as the electrical system itself must be properly grounded. Replacing frayed, exposed, or old wiring will also help to protect the operator and others from electrical shocks or electrocution. High pressure systems, too, need careful inspection and maintenance to prevent possible failure from pulsation, vibration, or leaks. Such a failure could cause, among other things, explosions or flying objects.

Machines often produce noise (unwanted sound) which can result in a number of hazards to workers.

Noise can startle and disrupt concentration, and can interfere with communications, thus hindering the worker's safe job performance. Research has linked noise to a whole range of harmful health effects, from hearing loss and aural pain to nausea, fatigue, reduced muscle control, and emotional disturbance. Engineering controls such as the use of sound-dampening materials, and personal protective equipment, such as ear plugs and muffs, can help control the harmful effects of noise. Also, administrative controls that involve removing the worker from the noise source can be an effective measure when feasible. See figure below.

Examples of Engineering Controls

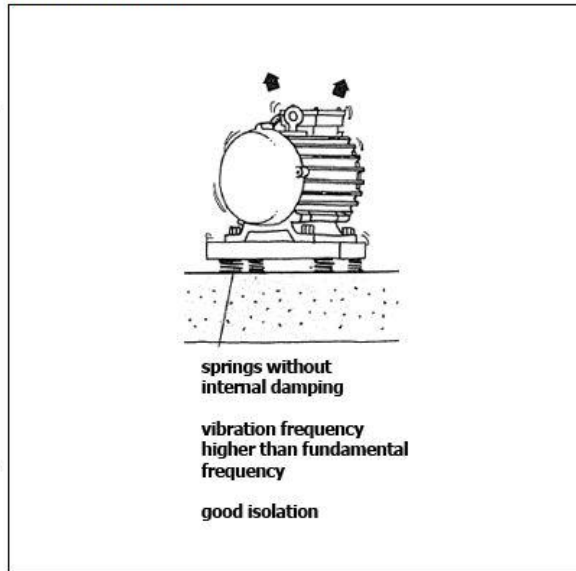
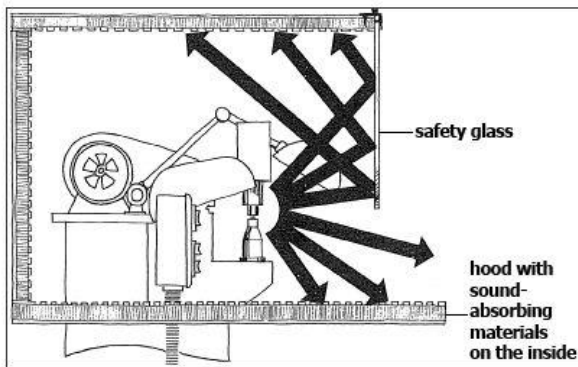

Because some machines require the use of cutting fluids, coolants, and other potentially harmful substances, operators, maintenance workers, and others in the vicinity may need protection.

These substances can cause ailments ranging from dermatitis to serious illnesses and disease. Specially constructed safeguards, ventilation, and protective equipment and clothing are possible temporary solutions to the problem of machinery-related chemical hazards until these hazards can be better controlled or eliminated from the workplace.

Training

Even the most elaborate safeguarding system cannot offer effective protection unless the worker knows how to use it and why. Specific and detailed training is therefore a crucial part of any effort to provide safeguarding against machine-related hazards. Thorough operator training should involve instruction or hands-on training in the following:

1. a description and identification of the hazards associated with particular machines
2. the safeguards themselves, how they provide protection, and the hazards for which they are intended
3. how to use the safeguards and why
4. how and under what circumstances safeguards can be removed, and by whom (in most cases, repair or maintenance personnel only)
5. what to do (e.g., contact the supervisor) if a safeguard is damaged, missing, or unable to provide adequate protection

This kind of safety training is necessary for new operators and maintenance or setup personnel, when any new or altered safeguards are put in service, or when workers are assigned to a new machine or operation.

Protective Clothing and Personal Protective Equipment

Using engineering controls to eliminate the hazard at the source, and not relying on the worker's behavior, offer the best and most reliable means of safeguarding. Therefore, engineering controls must be the employer's first choice for eliminating machine hazards. But whenever engineering controls are not available or are not fully capable of protecting the employee (an extra measure of protection is necessary), operators must wear protective clothing or personal protective equipment.

If it is to provide adequate protection, the protective clothing and equipment selected must always be:

1. appropriate for the particular hazards
2. maintained in good condition
3. properly stored when not in use, to prevent damage or loss
4. kept clean, fully functional, and sanitary

Protective clothing is, of course, available for different parts of the body. Hard hats can protect the head from the impact of bumps and falling objects; caps and hair nets can help keep the worker's hair from being caught in machinery. If machine coolants could splash or particles could fly into the operator's eyes or face, face shields, safety goggles, glasses, or similar kinds of protection may be necessary. Hearing protection may be needed when workers operate noisy machines. To guard the trunk of the body from cuts or impacts, there are certain protective coveralls, jackets, vests, aprons, and full-body suits. Workers can protect their hands and arms from the same kinds of injury with special sleeves and gloves. Safety shoes and boots, or other acceptable foot guards, can shield the feet against injury in case the worker needs to handle heavy objects which might drop on their feet.

It is important to note that protective clothing and equipment can create hazards. A protective glove which can become caught between rotating parts, or a respirator face piece which hinders the wearer's vision, for example, require alertness and continued attentiveness whenever they are used.

Other parts of the worker's clothing may present additional safety hazards. For example, loose-fitting shirts might possibly become entangled in rotating spindles or other kinds of moving machinery. Jewelry, such as bracelets and rings, can catch on machine parts or stock and lead to serious injury by pulling a hand into the danger area.

Module 1 Quiz

Use this quiz to self-check your understanding of the module content. You can also go online and take this quiz within the module. The online quiz provides the correct answer once submitted.

- 1. According to the text, any machine part, function, or process which may cause injury must be _____.**
 - a. reported to OSHA
 - b. safeguarded
 - c. de-energized
 - d. taken out of service

- 2. That point where work is performed on the material, such as cutting, shaping, boring, or forming of stock is called _____.**
 - a. the point of operation
 - b. transmission apparatus point
 - c. action point
 - d. the point at which work is performed

- 3. According to the text, power transmission apparatus components include all of the following, EXCEPT?**
 - a. flywheels
 - b. pulleys
 - c. slip joints
 - d. belts

- 4. Which of the following is an example of a nip point?**
 - a. the point of contact between a power transmission belt and its pulley
 - b. a chain and sprocket
 - c. a rack and pinion
 - d. each of the above

5. A safeguard need NOT do which of the following to protect workers against mechanical hazards?

- a. prevent contact
- b. protect from falling temperatures
- c. create no new hazards
- d. create no interference

Module 2: Methods of Machine Safeguarding - Guards

Introduction

There are many ways to safeguard machines. The type of operation, size or shape of stock, method of handling, physical layout of the work area, type of material, and production requirements or limitations will help to determine the appropriate safeguarding method for the individual machine.

As a general rule, power transmission apparatus is best protected by fixed guards that enclose the danger areas. For hazards at the point of operation, where moving parts actually perform work on stock, several kinds of safeguarding may be possible. One must always choose the most effective and practical means available.

The Five General Classifications of Safeguards

We can group safeguards under five general classifications.

1. Guards

- a. Fixed
- b. Interlocked
- c. Adjustable
- d. Self-adjusting

2. Devices

- a. Presence Sensing
 - i. Photoelectrical (optical)
 - ii. Radiofrequency (capacitance)
 - iii. Electromechanical
- b. Pullback
- c. Restraint
- d. Safety Controls
 - i. Safety trip control

1. Pressure-sensitive body bar
 2. Safety tripod
 3. Safety tripwire cable
- ii. Two-hand control
- iii. Two-hand trip
- e. Gates
 - i. Interlocked
 - ii. Other

3. Location/Distance

4. Potential Feeding and Ejection Methods to Improve Safety for the Operator

- a. Automatic feed
- b. Semi-automatic feed
- c. Automatic ejection
- d. Semi-automatic ejection
- e. Robot

5. Miscellaneous Aids

- a. Awareness barriers
- b. Miscellaneous protective shields
- c. Hand-feeding tools and holding fixtures

Guards

Guards are barriers which prevent access to danger areas. There are four general types of guards:

Fixed Guards

As its name implies, a fixed guard is a permanent part of the machine. It is not dependent upon moving parts to perform its intended function. It may be constructed of sheet metal, screen, wire cloth, bars, plastic, or any other material that is substantial enough to withstand whatever impact it may receive and to endure prolonged use. This guard is usually preferable to all other types because of its relative simplicity and permanence.

Examples of fixed guards

The figure to the right is an example of a fixed guard on a power press that completely encloses the point of operation. The stock is fed through the side of the guard into the die area, with the scrap stock exiting on the opposite side.

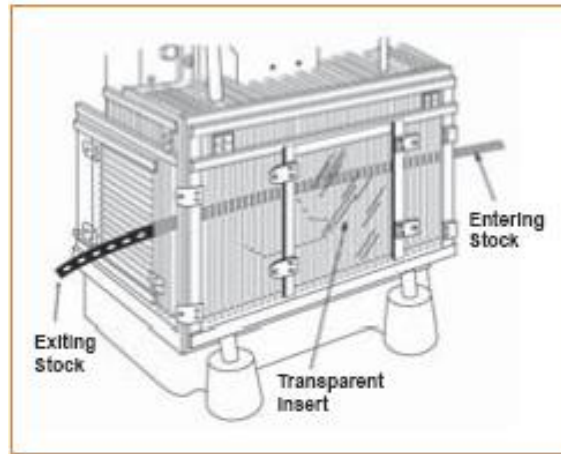

The figure below shows a fixed guard enclosing a belt and pulley system. Note the inspection panel allowing inspection of the system without exposure to the point of operation.

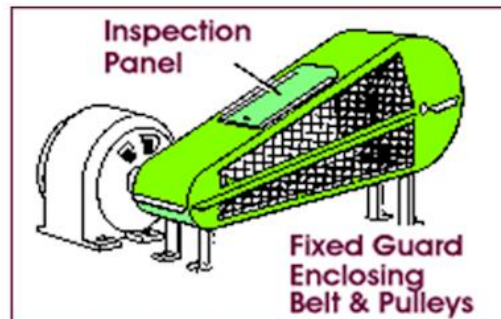

The figure below shows a fixed guard enclosing a band saw.

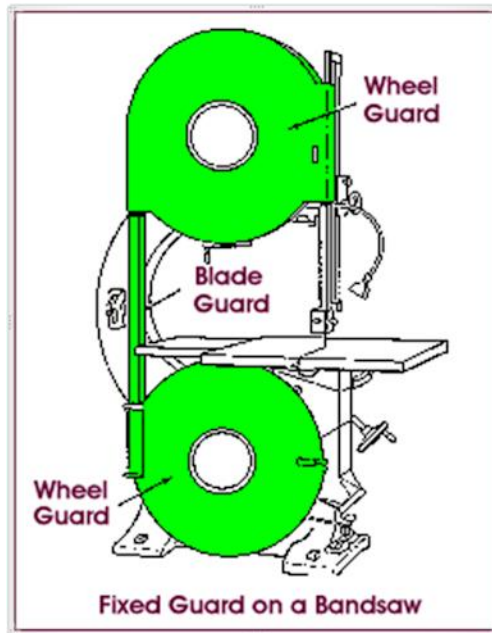

Interlocked Guards

When this type of guard is opened or removed, the tripping mechanism and/or power automatically shut off or disengage, and the machine cannot cycle or be started until the guard is back in place.

An interlocked guard may use electrical, mechanical, hydraulic, or pneumatic power or any combination of these. Interlocks should not prevent "inching" by remote control if required. Replacing the guard should not automatically restart the machine. To be effective, all movable guards should be interlocked to prevent occupational hazards.

In the figure below, the beater mechanism of a picker machine (used in the textile industry) is covered by an interlocked barrier guard. This guard cannot be raised while the machine is running, nor can the machine be restarted with the guard in the raised position.

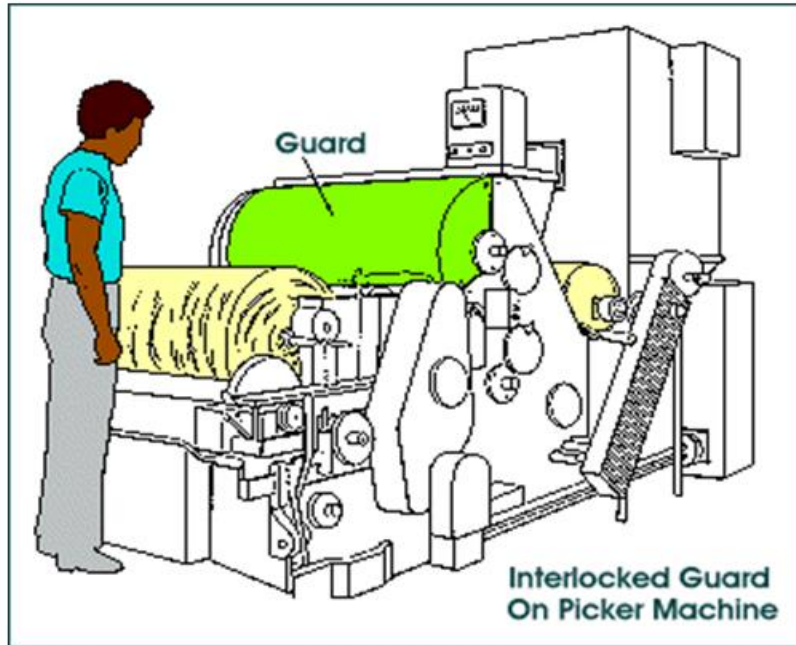

Adjustable Guards

Adjustable guards are useful because they allow flexibility in accommodating various sizes of stock.

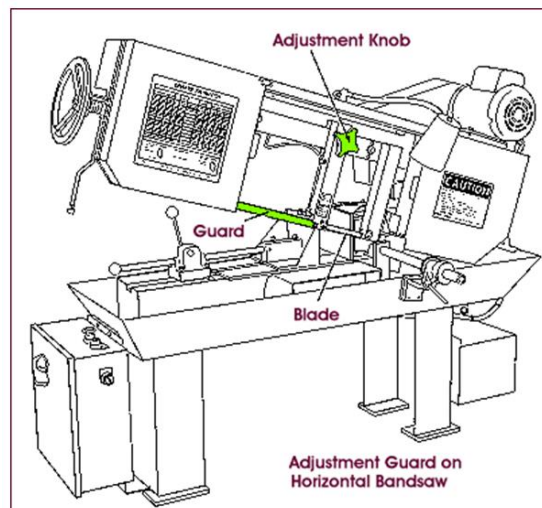

The figure below shows an adjustable enclosure guard on a band saw.

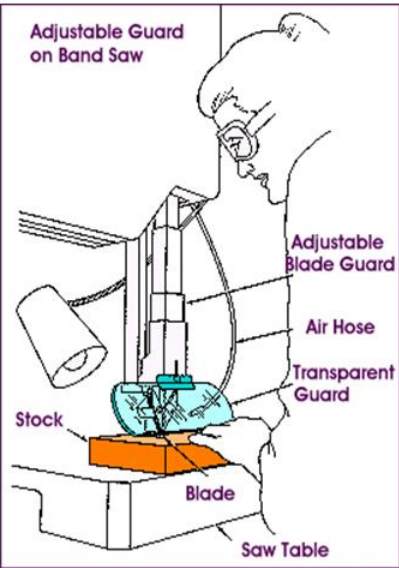

Self-Adjusting Guards

The openings of these barriers are determined by the movement of the stock. As the operator moves the stock into the danger area, the guard is pushed away, providing an opening which is only large enough to admit the stock. After the stock is removed, the guard returns to the rest position. This guard protects the operator by placing a barrier between the danger area and the operator. The guards may be constructed of plastic, metal, or other substantial material. Self-adjusting guards offer different degrees of protection.

The figure below shows a radial arm saw with a self-adjusting guard. As the blade is pulled across the stock, the guard moves up, staying in contact with the stock.

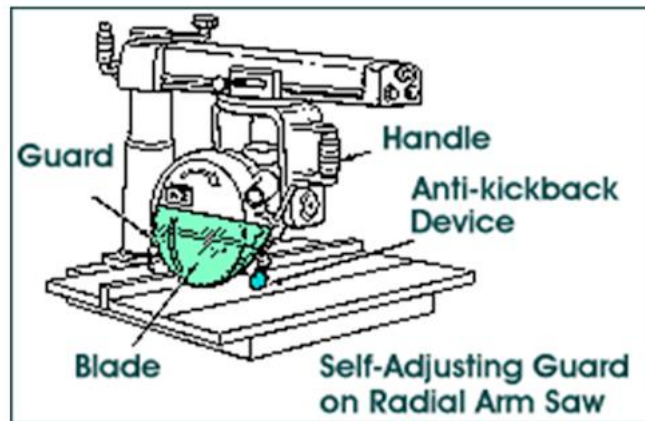

The figure to the right shows a self-adjusting enclosure guard mounted on a jointer. This guard is moved from the cutting head by the stock. After the stock is removed, the guard will return, under spring tension, to the rest position.

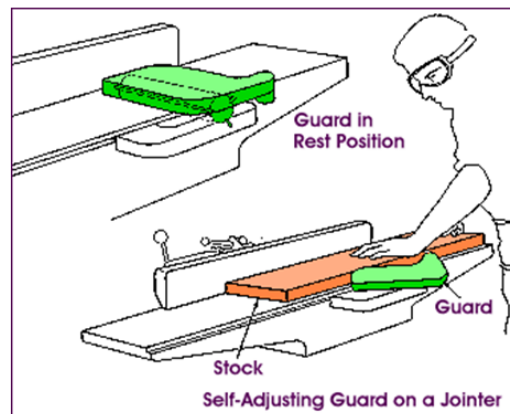

Module 2 Quiz

Use this quiz to self-check your understanding of the module content. You can also go online and take this quiz within the module. The online quiz provides the correct answer once submitted.

- 1. As a general rule, power transmission apparatus is best protected by which of the following?**
 - a. presence-sensing devices
 - b. warning signs placed between the worker and the work
 - c. fixed guards that enclose the danger area
 - d. mechanical arm restraints

- 2. Each of the following is one of the five general methods for safeguarding machinery, EXCEPT.**
 - a. timing and location
 - b. devices
 - c. guards
 - d. feeding and ejection methods

- 3. Which of the following is NOT one of the four types of machine guards?**
 - a. fixed
 - b. adjustable
 - c. interlocked
 - d. flexible

- 4. When this type of guard is opened or removed, the tripping mechanism and/or power automatically shut off or disengage, and the machine cannot cycle or be started until the guard is back in place.**
 - a. fixed
 - b. adjustable
 - c. interlocked
 - d. flexible

- 5. This guard is usually preferable to all other types because of its relative simplicity and permanence.**
- a. fixed
 - b. adjustable
 - c. interlocked
 - d. flexible

Module 3: Methods of Machine Safeguarding - Devices

Introduction

A safety device may perform one of several functions. It may stop the machine if a hand or any part of the body is inadvertently placed in the danger area; restrain or withdraw the operator's hands from the danger area during operation; require the operator to use both hands on machine controls, thus keeping both hands and body out of danger; or provide a barrier which is synchronized with the operating cycle of the machine in order to prevent entry to the danger area during the hazardous part of the cycle.

Presence-Sensing Devices

The photoelectric (optical) presence-sensing device uses a system of light sources and controls which can interrupt the machine's operating cycle; if the light field is broken, the machine stops and will not cycle.

This device must be used only on machines which can be stopped before the worker can reach the danger area. The design and placement of the guard depends upon the time it takes to stop the mechanism and the speed at which the employee's hand can reach across the distance from the guard to the danger zone.

The figure below shows a photoelectric presence-sensing device on a part-revolution power press. When the light beam is broken, either the ram will not start to cycle, or, if the cycle has begun, the stopping mechanism will be activated so that the press stops before the operator's hand can enter the danger zone.

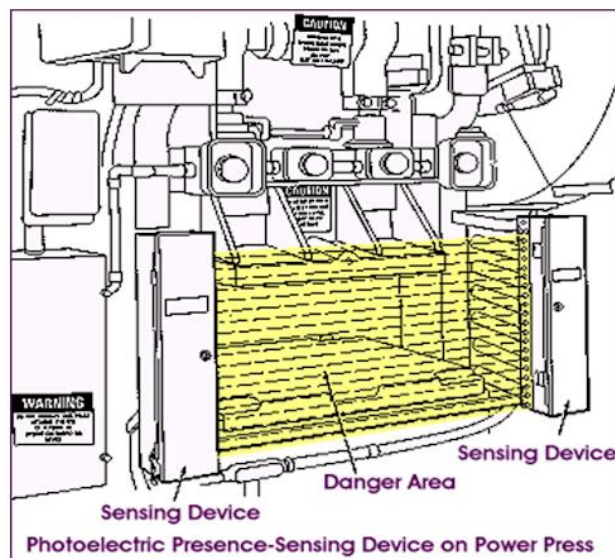

The figure below shows a radiofrequency presence-sensing device mounted on a part-revolution power press. The electromechanical sensing device has a probe or contact bar which descends to a predetermined distance when the operator initiates the machine cycle. If there is an obstruction preventing it from descending its full predetermined distance, the control circuit does not actuate the machine cycle.

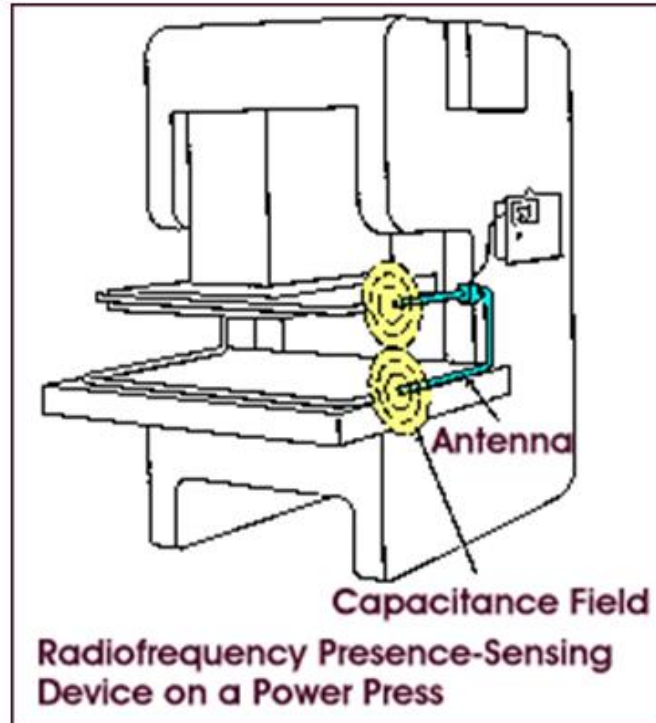

Pullback Devices

Pullback devices utilize a series of cables attached to the operator's hands, wrists, and/or arms. This type of device is primarily used on machines with stroking action. When the slide/ram is up between cycles, the operator is allowed access to the point of operation. When the slide/ram begins to cycle by starting its descent, a mechanical linkage automatically assures withdrawal of the hands from the point of operation.

The figure below shows a pullback device on a power press. When the slide/ram is in the "up" position, the operator can feed material by hand into the point of operation. When the press cycle is actuated, the operator's hands and arms are automatically withdrawn.

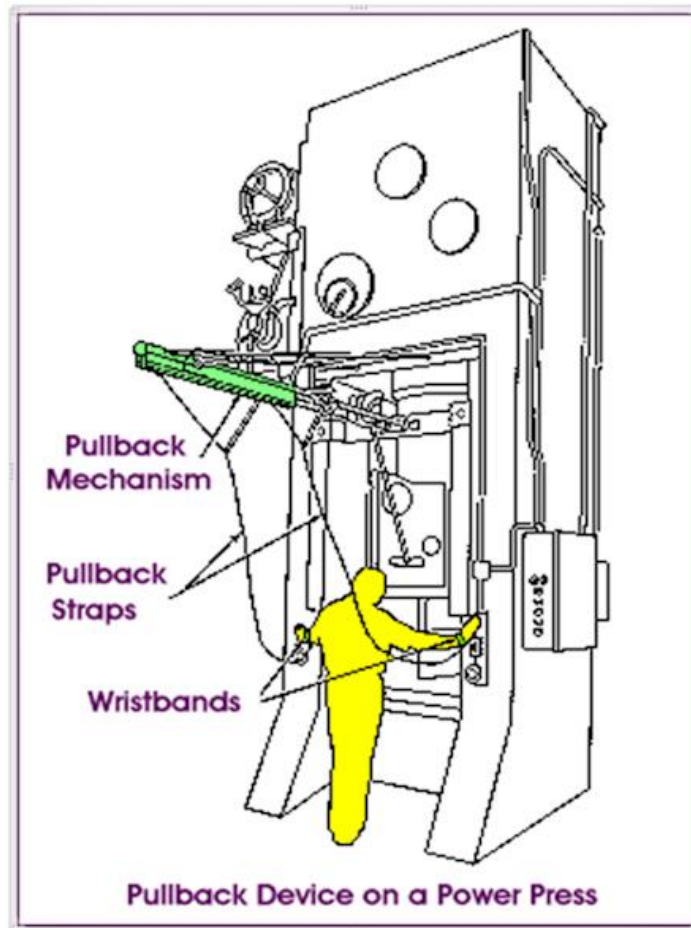

Restraint Devices

The restraint (holdout) device in the figure below uses cables or straps that are attached to the operator's hands at a fixed point. The cables or straps must be adjusted to let the operator's hands travel within a predetermined safe area. There is no extending or retracting action involved. Consequently, hand-feeding tools are often necessary if the operation involves placing material into the danger area.



Safety Trip Controls

Safety trip controls provide a quick means for deactivating the machine in an emergency situation.

A pressure-sensitive body bar, when depressed, will deactivate the machine. If the operator or anyone trips, loses balance, or is drawn toward the machine, applying pressure to the bar will stop the operation. The positioning of the bar, therefore, is critical. It must stop the machine before a part of the employee's body reaches the danger area. The figure here shows a pressure-sensitive body bar located on the front of a rubber mill.

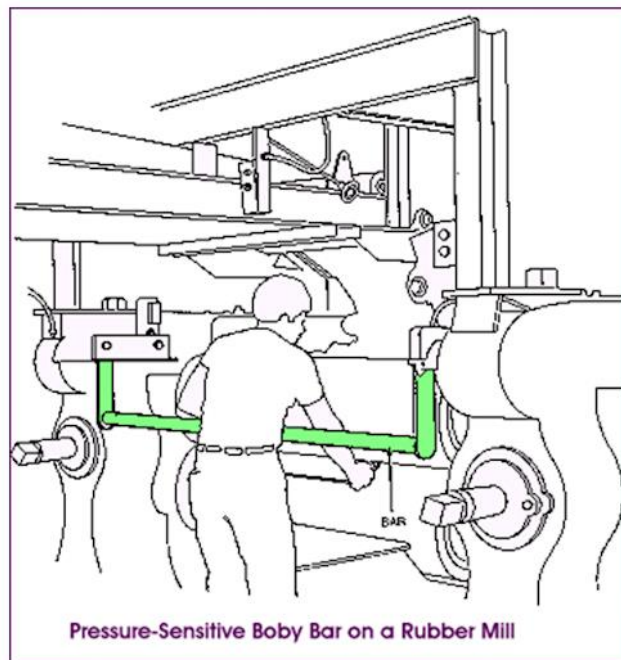

Two-Hand Control Devices

The two-hand control requires constant, concurrent pressure by the operator to activate the machine. This kind of control requires a part-revolution clutch, brake, and a brake monitor if used on a power press as shown in the figure below. With this type of device, the operator's hands are required to be at a safe location (on control buttons) and at a safe distance from the danger area while the machine completes its closing cycle.

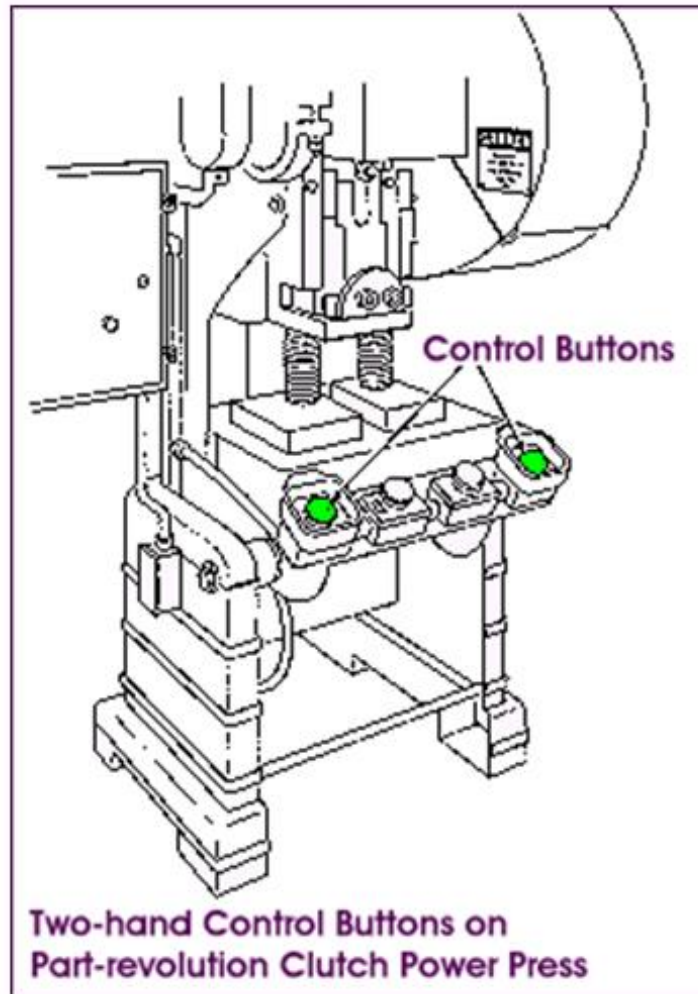

Two-Hand Trip Devices

The two-hand trip in the figure below requires concurrent application of both the operator's control buttons to activate the machine cycle, after which the hands are free. This device requires the joint operation of two trigger buttons located away from the "danger zone" of the press. To be effective, both two-hand controls and trips must be located so that the operator cannot use two hands or one hand and another part of his/her body to trip the machine.

Activation of the machine stroke requires only a "trip" of the controls whereas a two-hand control requires continued pressure. The two-hand trip requires the operator's hands to be away from the point of operation to activate the machine stroke.

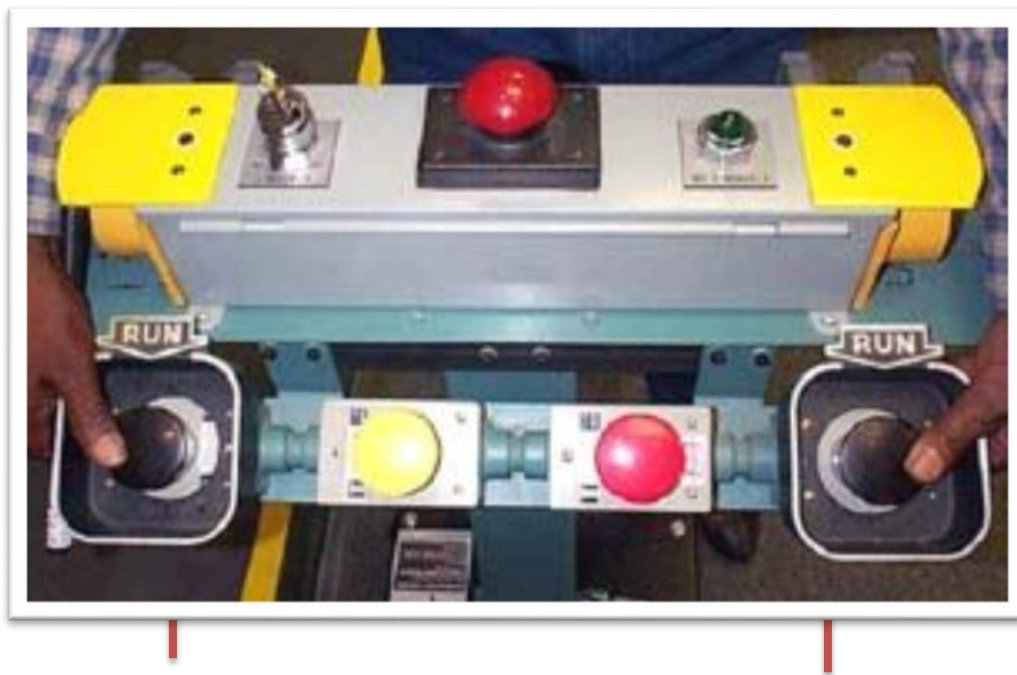

Module 3 Quiz

Use this quiz to self-check your understanding of the module content. You can also go online and take this quiz within the module. The online quiz provides the correct answer once submitted.

- 1. What happens when the light field is broken while using a photoelectric presence-sensing device?**
 - a. an alarm sounds
 - b. the machine works since no one is present
 - c. the machine stops and will not cycle
 - d. strobe lights begin flashing

- 2. These devices use a series of cables attached to the operator's hands, wrists, and/or arms.**
 - a. pullback devices
 - b. presence-sensing devices
 - c. two-hand trip devices
 - d. restraint devices

- 3. These devices require concurrent application of both the operator's control buttons to activate the machine cycle, after which the hands are free.**
 - a. pullback devices
 - b. presence-sensing devices
 - c. two-hand trip devices
 - d. restraint devices

- 4. These devices use cables or straps that are attached to the operator's hands at a fixed point.**
 - a. pullback devices
 - b. safety trip controls
 - c. restraint devices
 - d. fixed devices

- 6. These devices require constant, concurrent pressure by the operator to activate the machine.**
- a. pullback devices
 - b. safety trip controls
 - c. restraint devices
 - d. two-hand control

Module 4: More Safeguarding Methods

Safeguarding by Location and Distance

In order for a machine to be considered “safeguarded by location,” the dangerous moving part of the machine must be positioned so those “guarded” areas are not accessible or do not present a hazard to a worker during the normal operation of the machine.

This may be accomplished by locating a machine so that the hazardous parts of the machine are located away from operator work stations or other areas where employees walk or work. This can be accomplished by positioning a machine with its power transmission apparatus against a wall and leaving all routine operations conducted on the other side of the machine. Additionally, enclosure walls or fences can restrict access to machines. Another possible solution is to have dangerous parts located high enough to be out of the normal reach of any worker.

The feeding process can be safeguarded by location if a safe distance can be maintained to protect the worker's hands. The dimensions of the stock being worked on may provide adequate safety.

For instance, if the stock is several feet long and only one end of the stock is being worked on, the operator may be able to hold the opposite end while the work is being performed. An example would be a single-end punching machine. However, depending upon the machine, protection might still be required for other personnel.

The positioning of the operator's control station provides another potential approach to safeguarding by location. Operator controls may be located at a safe distance from the machine if there is no reason for the operator to tend it.

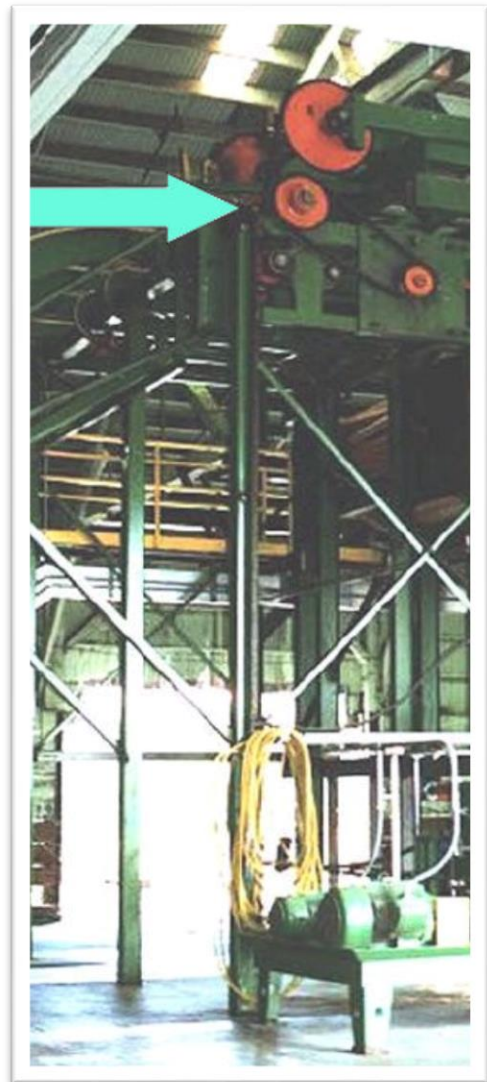

Feeding the Ejection Methods

Many feeding and ejection methods do not require the operator to place his or her hands in the danger area. In some cases, no operator involvement is necessary after the machine is set up. In other situations, operators can manually feed the stock with the assistance of a feeding mechanism. Properly designed ejection methods do not require any operator involvement after the machine starts to function.

Some feeding and ejection methods may even create hazards themselves. For instance, a robot may eliminate the need for an operator to be near the machine but may create a new hazard itself by the movement of its arm.

Using these feeding and ejection methods does not eliminate the need for guards and devices. Guards and devices must be used wherever they are necessary and possible in order to provide protection from exposure to hazards.

Automatic Feed Systems

Automatic feeds such as the figure to the right reduce the exposure of the operator during the work process, and sometimes do not require any effort by the operator after the machine is set up and running.

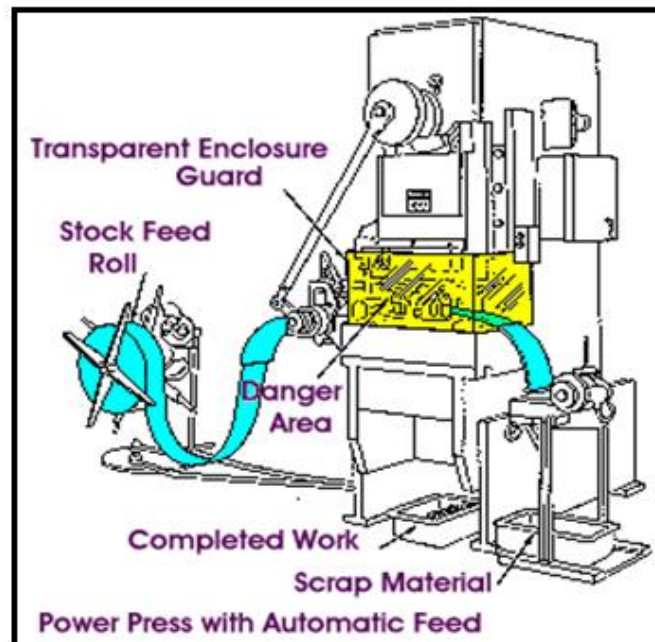

Semi-Automatic Feeding Systems

With semiautomatic feeding, as in the case of a power press, the operator uses a mechanism to place the piece being processed under the ram at each stroke. The operator does not need to reach into the danger area, and the danger area is completely enclosed.

The figure to the right shows a chute feed. It may be either a horizontal or an inclined chute into which each piece is placed by hand. Using a chute feed on an inclined press not only helps center the piece as it slides into the die, but may also simplify the problem of ejection.



Semi-Automatic Ejection Systems

The figure to the right shows a semiautomatic ejection mechanism used on a power press. When the plunger is withdrawn from the die area, the ejector leg, which is mechanically coupled to the plunger, kicks the completed work out.

Semiautomatic Ejection

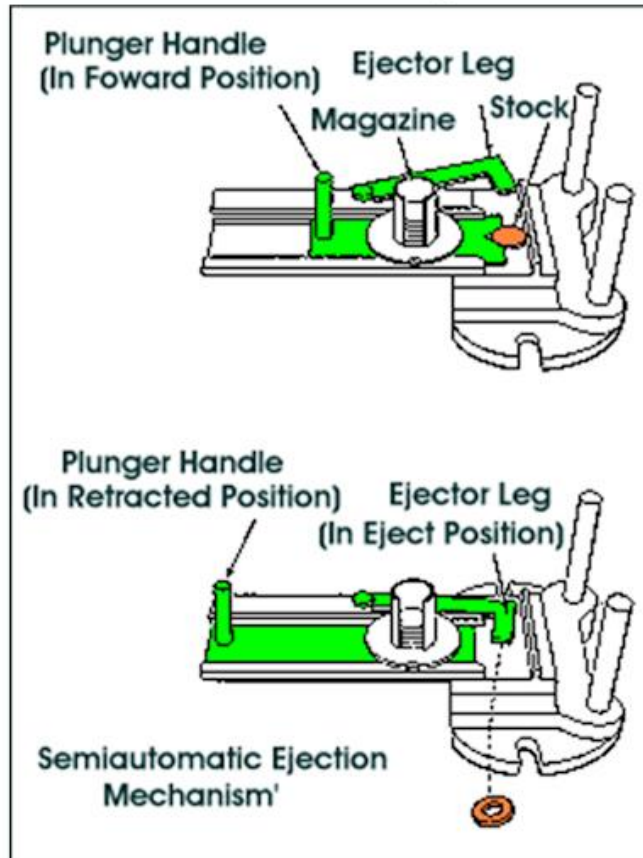

Robot Systems

Essentially, robots perform work that would otherwise have to be done by an operator. They are best used in high-production processes requiring repeated routines where they prevent other hazards to employees. However, they may create hazards themselves, and if they do, appropriate guards must be used.

Robots are machines that load and unload stock, assemble parts, transfer objects, or perform other tasks.

Robots are used for replacing humans who were performing unsafe, hazardous, highly repetitive, and unpleasant tasks. They are utilized to accomplish many different types of application functions such as material handling, assembly, arc welding, resistance welding, machine tool load/unload functions, painting/spraying, etc.

All industrial robots are either servo or non-servo controlled.

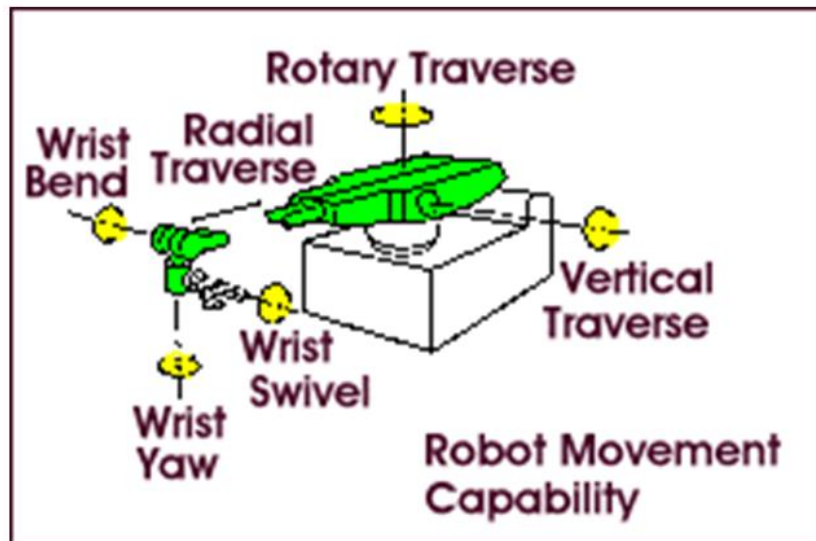

Servo robots are controlled through the use of sensors which are employed to continually monitor the robot's axes for positional and velocity feedback information. This feedback information is compared on an on-going basis to pre-taught information which has been programmed and stored in the robot's memory.

Non-servo robots do not have the feedback capability of monitoring the robot's axes and velocity and comparing with a pre-taught program. Their axes are controlled through a system of mechanical stops and limit switches to control the robot's movement.

Types of Robot Hazards

The use of robotics in the workplace also can pose potential mechanical and human hazards.

Mechanical hazards might include workers colliding with equipment, being crushed, or trapped by equipment, or being injured by falling equipment components. For example, a worker could collide with the robot's arm or peripheral equipment as a result of unpredicted movements, component malfunctions, or unpredicted program changes.

A worker could be injured by being trapped between the robot's arm and other peripheral equipment or being crushed by peripheral equipment as a result of being impacted by the robot into this equipment.

Mechanical hazards also can result from the mechanical failure of components associated with the robot or its power source, drive components, tooling or end-effector, and/or peripheral equipment. The failure of gripper mechanisms with resultant release of parts, or the failure of end-effector power tools such as grinding wheels, buffing wheels, de-burring tools, power screwdrivers, and nut runners to name a few.

Human errors can result in hazards both to personnel and equipment. Errors in programming, interfacing peripheral equipment, connecting input/output sensors, can all result in unpredicted movement or action by the robot which can result in personnel injury or equipment breakage.

Human errors in judgment result frequently from incorrectly activating the teach pendant or control panel. The greatest human judgment error results from becoming so familiar with the robot's redundant motions that personnel are too trusting in assuming the nature of these motions and place themselves in hazardous positions while programming or performing maintenance within the robot's work envelope.

The figures below show a type of robot in operation, the danger areas it can create, and an example of the kind of task (feeding a press) it can perform.

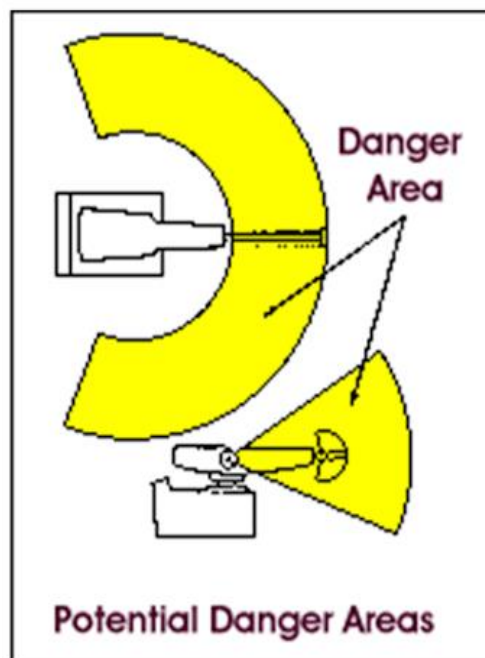
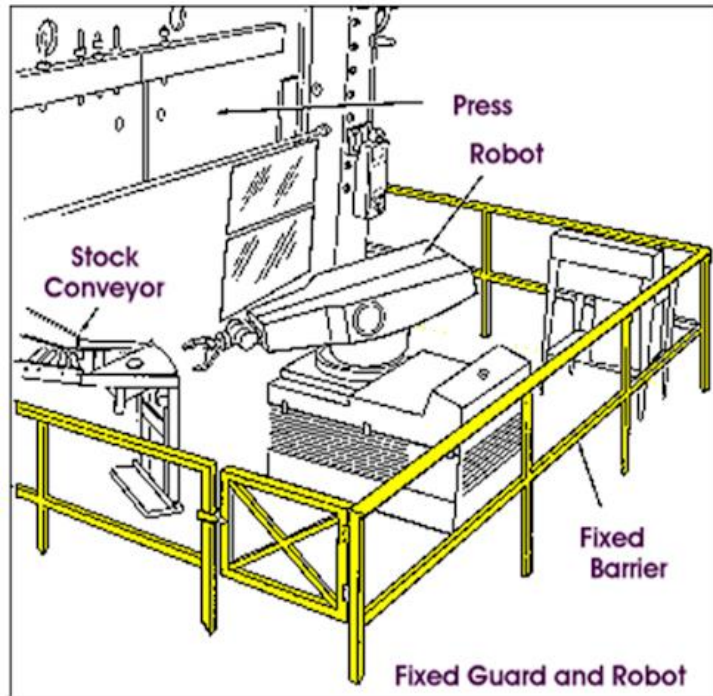

Miscellaneous Aids

While these aids do not give complete protection from machine hazards, they may provide the operator with an extra margin of safety. Sound judgment is needed in their application and usage. Below are several examples of possible applications.

An **awareness barrier** does not provide physical protection, but serves only to remind a person that he or she is approaching the danger area. Generally, awareness barriers are not considered adequate when continual exposure to the hazard exists.

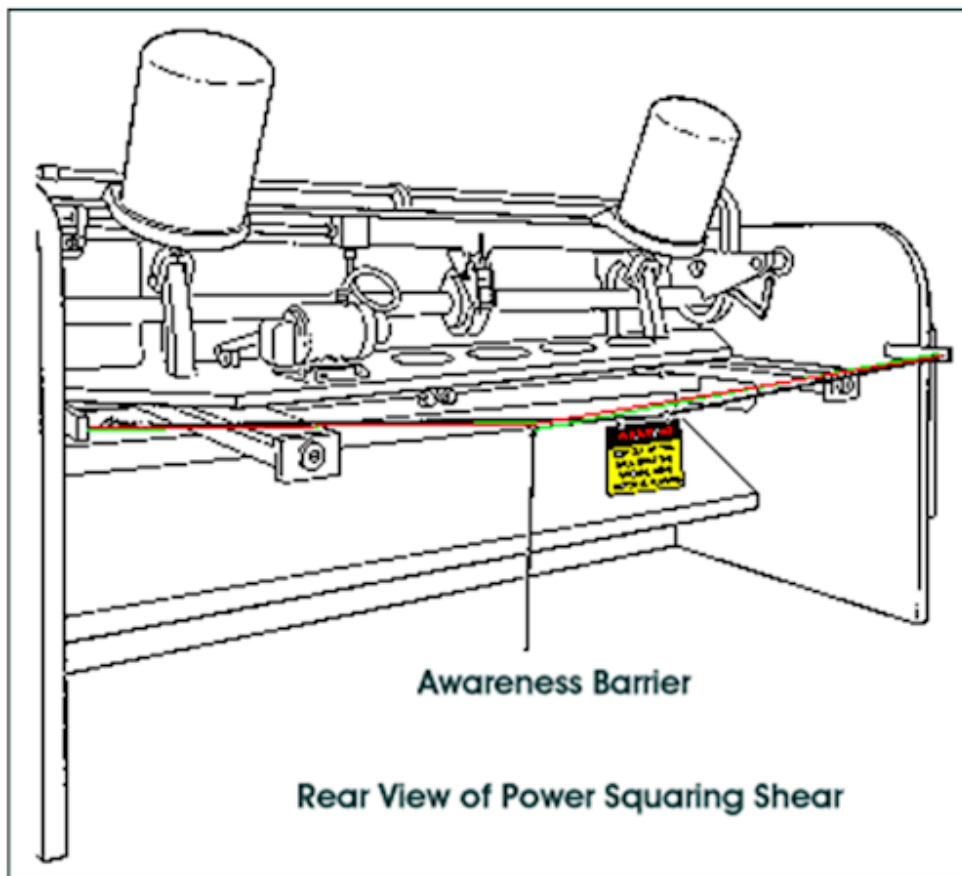

The figure above shows a rope used as an awareness barrier on the rear of a power squaring shear. Although the barrier does not physically prevent a person from entering the danger area, it calls attention to it. For an employee to enter the danger area an overt act must take place, that is, the employee must either reach or step over, under or through the barrier.

Shields, another aid, may be used to provide protection from flying particles, splashing cutting oils, or coolants. The figure below shows more potential applications.

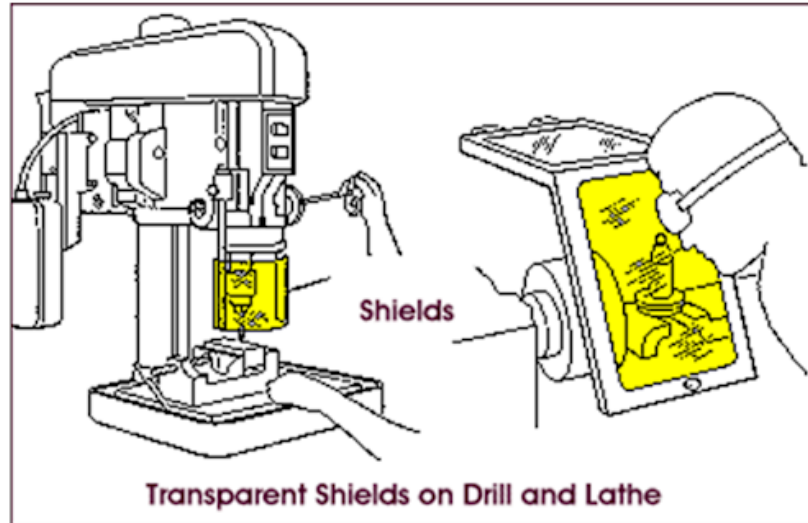

Special hand tools may be used to place or remove stock, particularly from or into the point of operation of a machine. A typical use would be for reaching into the danger area of a press or press brake. The figure to the right shows an assortment of tools for this purpose. Holding tools should not be used instead of other machine safeguards; they are merely a supplement to the protection that other guards provide.

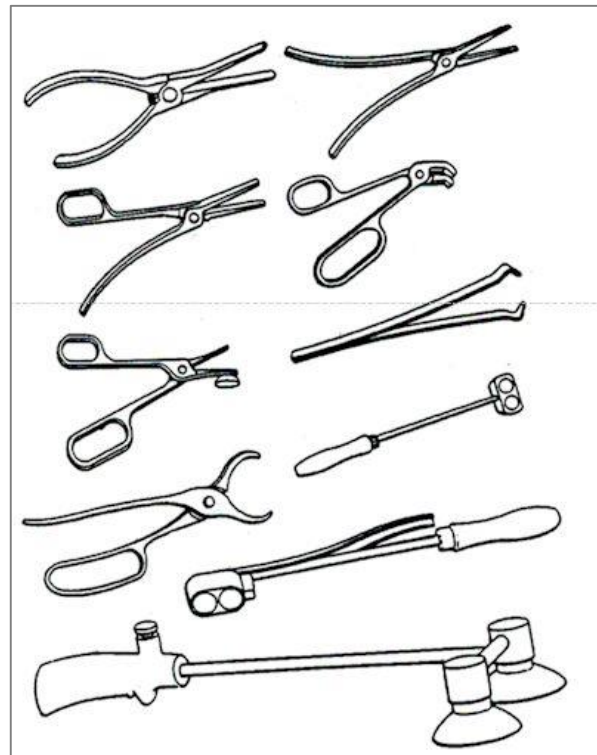

A push stick or block, may be used when feeding stock into a saw blade. When it becomes necessary for hands to be in close proximity to the blade, the push stick or block may provide a few inches of safety and prevent a severe injury. In the illustration to the right the push block fits over the fence.

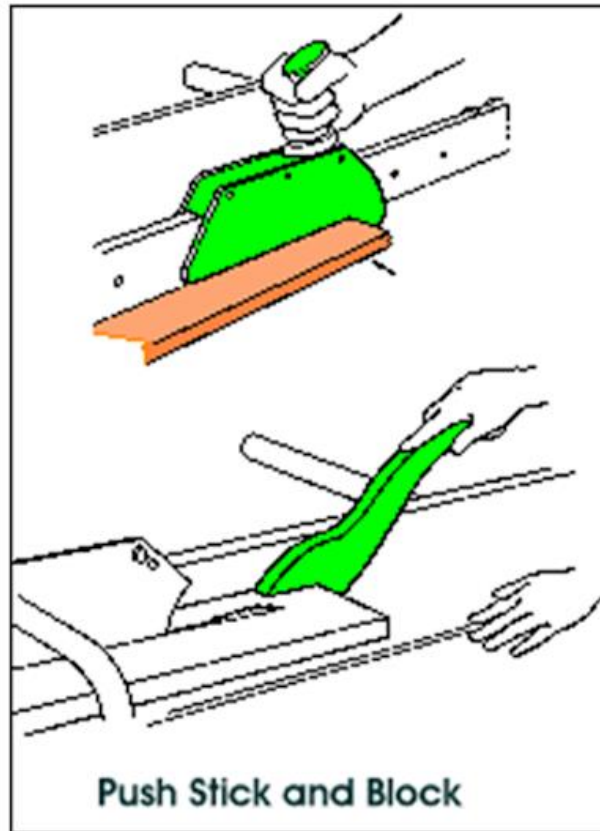

Module 4 Quiz

Use this quiz to self-check your understanding of the module content. You can also go online and take this quiz within the module. The online quiz provides the correct answer once submitted.

- 1. To consider a part of a machine to be safeguarded by location, the dangerous moving part of a machine must be so positioned that those areas _____.**
 - a. are not accessible
 - b. are not within arm's length
 - c. do not present a hazard during normal operation
 - d. a and c above

- 2. These feed methods sometimes do not require any effort by the operator after the machine is set up and running.**
 - a. semi-automatic feeds
 - b. semi-automatic ejection
 - c. Automatic feeds
 - d. Automatic injection

- 3. These methods do not provide physical protection, but serve only to remind a person that he or she is approaching the danger area.**
 - a. awareness barriers
 - b. transparent shields
 - c. miscellaneous aids
 - d. hand tools

- 4. These devices may be used to place or remove stock, particularly from or into the point of operation of a machine.**
 - a. awareness barriers
 - b. transparent shields
 - c. miscellaneous aids
 - d. hand tools

5. **A push stick or block, such as those in the below figure may be used when feeding stock into a saw blade.**
- a. True
 - b. False

Module 5: Machine Guard Construction

Guard Construction

Today many builders of single-purpose machines provide point-of-operation and power transmission safeguards as standard equipment. However, not all machines in use have built-in safeguards provided by the manufacturer.

Advantages of Builder-Designed Guards

Guards designed and installed by the builder offer two main advantages:

- They usually conform to the design and function of the machine.
- They can be designed to strengthen the machine in some way or to serve some additional functional purposes.

Advantages of User-Built Guards

User-built guards are sometimes necessary for a variety of reasons. They provide the following advantages:

- Often, with older machinery, they are the only practical safeguarding solution.
- They may be the only choice for mechanical power transmission apparatus in older plants, where machinery is not powered by individual motor drives.
- They permit options for point-of-operation safeguards when skilled personnel design and make them.
- They can be designed and built to fit unique and even changing situations.
- They can be installed on individual dies and feeding mechanisms.
- Design and installation of machine safeguards by plant personnel can help to promote safety consciousness in the workplace.

Disadvantages of User-Built Guards

User-built guards also have disadvantages:

- User-built guards may not conform well to the configuration and function of the machine.

- There is a risk that user-built guards may be poorly designed or built.

Point-of-Operation Guards

Point-of-operation guards are designed to prevent workers from accidentally or intentionally inserting a finger, hand, foot, or any other body part into the operating machine.

Point-of-operation safeguarding is complicated by the number and complexity of machines and also by the different uses for individual machines. For these reasons, not all machine builders provide point-of-operation guards on their products.

In many cases a point-of-operation guard can only be made and installed by the user after a thorough hazard analysis of the work requirements. Poorly designed, built or installed guards may create a hazard rather than eliminate one.

To be effective they must safeguard the employee while allowing the work to continue with minimum disruption to the production process.

Mechanical Power Transmission Apparatus Guarding

A significant difference between power transmission guards and point-of-operation guards is that the former type needs no opening for feeding stock. The only openings necessary for power transmission guards are those for lubrication, adjustment, repair, and inspection. These openings should be provided with interlocked covers that cannot be removed except by using tools for service or adjustment.

To be effective, power transmission guards should cover all moving parts in such a manner that no part of the operator's body can come in contact with them.

Guard Material

Under many circumstances, metal is the best material for guards. Guard framework is usually made from structural shapes, pipe, bar, or rod stock. Filler material generally is expanded or perforated or solid sheet metal or wire mesh. It may be feasible to use plastic or safety glass where visibility is required.

Guards made of wood generally are not recommended because of their flammability and lack of durability and strength. However, in areas where corrosive materials are present, wooden guards may be the better choice.

Module 5 Quiz

Use this quiz to self-check your understanding of the module content. You can also go online and take this quiz within the module. The online quiz provides the correct answer once submitted.

- 1. Guards designed and installed by the builder offer two main advantages:**
 - a. They conform to design and function
 - b. They can strengthen the machine
 - c. They may be more costly to build
 - d. both a and b above

- 2. Which of the following is an advantage of installing user-built guards?**
 - a. They may be the only practical solution
 - b. They can be designed to fit unique situations
 - c. They can be installed on individual dies and feeding mechanisms
 - d. All of the above

- 3. To be effective, power transmission guards should cover all moving parts in such a manner that _____ cannot come in contact with them.**
 - a. any part of the operator's body
 - b. fingers and hands
 - c. the head or hair
 - d. feet or legs

- 4. Design and installation of machine safeguards by plant personnel can help to promote safety consciousness in the workplace.**
 - a. True
 - b. False

- 5. Guards made of wood generally are recommended because of their low flammability and high durability and strength.**
 - a. True
 - b. False

Module 6: Machinery Maintenance and Repair

Machinery Maintenance and Repair

Good maintenance and repair procedures contribute significantly to the safety of the maintenance crew as well as that of machine operators. The variety and complexity of machines to be serviced, the hazards associated with their power sources, the special dangers that may be present during machine breakdown, and the severe time constraints often placed on maintenance personnel all make safe maintenance and repair work difficult.

Hazard Identification and Reporting

Training and aptitude of people assigned to these jobs should make them alert for the intermittent electrical failure, the worn part, the inappropriate noise, the cracks or other signs that warn of impending breakage or that a safeguard has been damaged, altered, or removed.

By observing machine operators at their tasks and listening to their comments, maintenance personnel may learn where potential trouble spots are and give them early attention before they develop into sources of accidents and injury.

Sometimes all that is needed to keep things running smoothly and safely is machine lubrication or adjustment. Any damage observed or suspected should be reported to the supervisor; if the condition impairs safe operation, the machine should be out of service for repair. Safeguards that are missing, altered, or damaged also should be reported so appropriate action can be taken to insure against worker injury.

Machine Guard Design Considerations

If possible, machine design should permit routine lubrication and adjustment without removal of safeguards. But when safeguards must be removed, and the machine serviced, the lockout procedure of 29 CFR 1910.147 must be adhered to. The maintenance and repair crew must never fail to replace the guards before the job is considered finished and the machine released from lockout.

Is it necessary to oil machine parts while a machine is running? If so, special safeguarding equipment may be needed solely to protect the oiler from exposure to hazardous moving parts. Maintenance personnel must know which machines can be serviced while running and which cannot. "If in doubt, lock it out." Obviously, the danger of accident or injury is reduced by shutting off and locking out all sources of energy.

Sources of Hazardous Energy during Maintenance and Repair

In situations where the maintenance or repair worker would necessarily be exposed to electrical elements or hazardous moving machine parts in the performance of the job, there is no question that all power sources must be shut off and locked out before work begins. Warning signs or tags are inadequate insurance against the untimely energizing of mechanical equipment.

Thus, one of the first procedures for the maintenance person is to disconnect and lock out the machine from all of its power sources, whether the source is electrical, mechanical, pneumatic, hydraulic, or a combination of these. Energy accumulation devices must be "bled down."

Electrical Energy Hazards

Unexpected energizing of any electrical equipment that can be started by automatic or manual remote control may cause electric shock or other serious injuries to the machine operator, the maintenance worker, or others operating adjacent machines controlled by the same circuit.

For this reason, when maintenance personnel must repair electrically powered equipment, they should open the circuit at the switch box and padlock the switch (lock it out) in the "off" position.

This switch should be tagged with a description of the work being done, the name of the maintenance person, and the department involved. When more than one worker is to be engaged in the servicing/maintenance function a lockout hasp may be used to which each may affix a personal lock.

Mechanical Energy Hazards

The figure to the right shows safety blocks being used as an additional safeguard on a mechanical power press, even though the machine has been locked out. The safety blocks prevent the ram from coming down under its own weight.



Pneumatic and Hydraulic Energy Hazards

The figure to the right shows a lockout valve. The lever-operated valve used during repair or shutdown to keep a machine or its components from operating can be locked open or shut. Before the valve can be opened, everyone working on the machine must use his or her own key to release the lockout.

A sliding-sleeve valve exhausts line pressure at the same time it cuts off the air supply. Valves used to lock out pneumatic or hydraulic-powered machines should be designed to accept locks or lockout adapters and should be capable of "bleeding off" pressure residues that could cause any part of the machine to move.

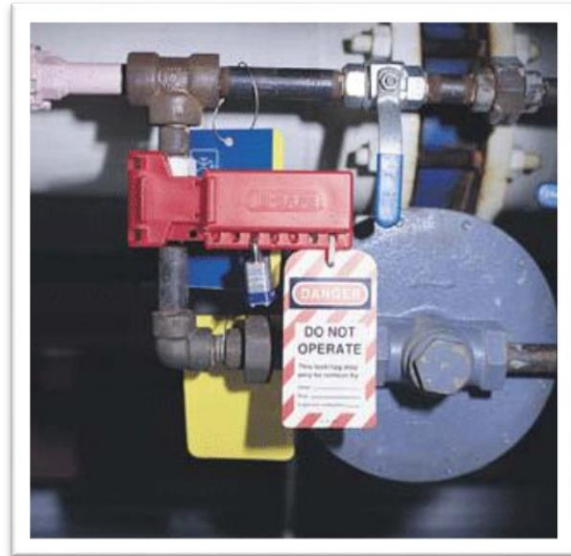

Performing Lockout/Tagout (LOTO) Procedures

In order to prevent the hazards we have discussed, each machine or piece of equipment should be safeguarded during the conduct of servicing or maintenance by:

1. notifying all affected employees (usually machine or equipment operators or users) that the machine or equipment must be shut down to perform some maintenance or servicing
2. stopping the machine
3. isolating the machine or piece of equipment from its energy source
4. locking out or tagging out the energy source
5. relieving any stored or residual energy
6. verifying the machine or equipment is isolated from the energy source

Although this is the general rule, exceptions can be made when the servicing or maintenance is not hazardous for an employee, is minor in nature, and is done as an integral part of production and the employer utilizes alternative safeguards which provide effective protection as is required by OSHA standards.

Release from Lockout/Tagout Procedures

When the servicing or maintenance is completed, there are specific steps which must be taken to return the machine or piece of equipment to service. These steps include:

1. inspection of the machine or equipment to ensure that all guards and other safety devices are in place and functional
2. checking the area to ensure that energization and start-up of the machine or equipment will not endanger employees
3. removal of the lockout devices
4. re-energization of the machine or equipment
5. notification of affected employees that the machine or equipment may be returned to service

The steps to lockout described above are only a part of the total energy control program which must exist in the workplace. In addition, the employer should:

- develop procedures for all machines and equipment
- train employees in their duties and responsibilities under the energy control program, and
- periodically inspect performance to maintain the effectiveness of the program.

Scenario: Mine Fatality

Introduction

On May 26, 1998, a 56-year old crusher operator with 5 days experience at this mine and 20 years total mining experience was killed at a sand and gravel operation. The victim was walking toward the crushing plant and apparently passed too close to the rotating drive shaft and coupling that connected the crusher to the drive unit. He became entangled in the drive shaft and coupling, which were not guarded.

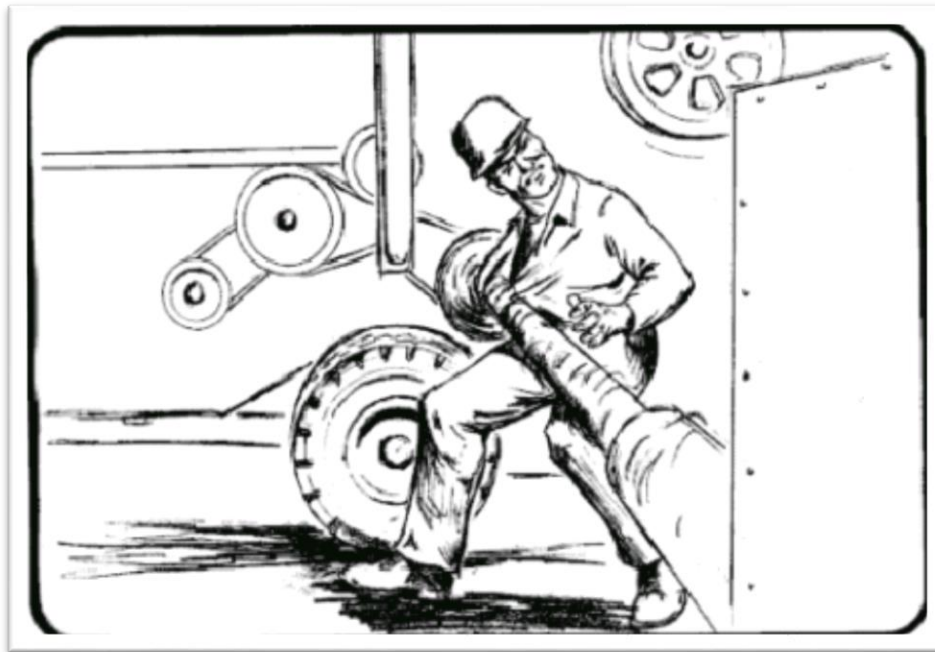

Best Practices

Moving machine parts must be guarded to protect persons from inadvertent contact.

New employees should be indoctrinated in safety rules and safe work procedures.

Examinations of working places should be performed at least once each shift and corrections should be initiated by the operator to address safety and health hazards.

Description of the Accident

On the day of the accident, Deloy Stewart (victim) reported to the main shop at Bicknell, Utah, for work at 8:00 a.m., his regular starting time. Stewart and Bill Jones, front-end loader operator, drove to the crusher, arriving about 8:30 a.m. Stewart started the plant while Jones

dumped one bucket of pit run material in the plant feed hopper. Jones changed front-end loaders at this time because a window was missing from the cab. He discovered that the loader he had switched to was low on crankcase oil and informed Stewart of the problem. Stewart brought Jones the oil and then returned to monitor the plant.

Jones needed a funnel to add oil to the loader and when he left to get a funnel, he discovered that Stewart was caught in the rotating shaft at the universal joint. Jones moved Stewart away from the shaft and placed him on the ground. Realizing that Stewart was seriously injured, Jones called for help on his CB radio. A truck driver intercepted Jones's call and subsequently notified the local Sheriff's office. Arrangements were made to air lift the victim to a hospital; however, he died on site a short time later.

Conclusion

The primary cause of the accident was failure to guard the drive shaft. Failure to indoctrinate the victim in safety rules and safe work procedures may have been a contributing factor.

Module 6 Quiz

Use this quiz to self-check your understanding of the module content. You can also go online and take this quiz within the module. The online quiz provides the correct answer once submitted.

- 1. According to the text, what should the worker do first if he or she discovers or suspects any damage to machinery?**
 - a. bypass reporting and immediately fix the problem
 - b. report it immediately to the supervisor
 - c. immediately place the machinery out of service
 - d. if it's not in your department, just ignore it

- 2. What is required when safeguards must be removed, and the machine serviced?**
 - a. Lockout/Tagout (LOTO) procedures
 - b. maintenance inspection of all parts
 - c. thorough lubrication and cleaning
 - d. Job Hazard Analysis (JHA)

- 3. Which of the following is a possible source of hazardous energy during maintenance and repair of machinery?**
 - a. Electrical
 - b. Mechanical
 - c. Pneumatic and Hydraulic
 - d. All of the above

- 4. Warning signs or tags are inadequate insurance against the untimely energizing of mechanical equipment during maintenance.**
 - a. True
 - b. False

- 5. Maintenance personnel must know which machines can be serviced while running and which cannot. Remember, "If in doubt, _____."**
- a. report it to someone
 - b. leave it alone
 - c. lock it out
 - d. take a chance