

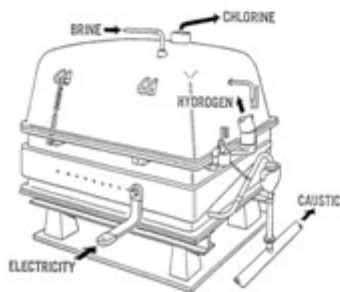

OXYCHEM

# CHLORINE HANDBOOK

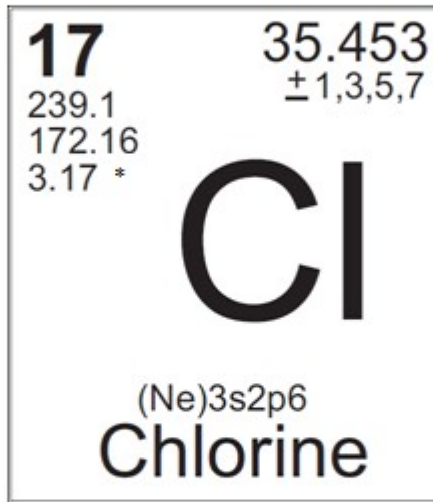



Occidental Chemical Corporation (OxyChem) is a leading North American manufacturer of polyvinyl chloride (PVC) resins, chlorine and caustic soda, key building blocks for a variety of indispensable products such as plastics, pharmaceuticals and water treatment chemicals. Other OxyChem products include caustic potash, chlorinated organics, sodium silicates, chlorinated isocyanurates and calcium chloride. For every product it makes, OxyChem's market position is No. 1 or No. 2 in the U.S. and No. 1, 2 or 3 in the world. Based in Dallas, Texas, the company has manufacturing facilities in the United States, Canada, Chile and Brazil.

OxyChem has been an active participant in the American Chemistry Council's Responsible Care® initiative since its inception in 1988. Demonstrating their commitment to attaining the highest levels of safety and environmental achievement, Responsible Care companies implement world-class management systems, measure performance based on industry wide metrics, and are subject to review by independent auditors.

#### Foreword

This handbook outlines recommended methods for handling, storing, and using chlorine. It also includes information on the manufacture and physical properties of chlorine. Additional information and contacts can be found on the internet at [www.oxychem.com](http://www.oxychem.com)

**"IMPORTANT: THE INFORMATION PRESENTED HEREIN, WHILE NOT GUARANTEED, WAS PREPARED BY TECHNICAL PERSONNEL AND IS TRUE AND ACCURATE TO THE BEST OF OUR KNOWLEDGE. NO WARRANTY OF MERCHANTABILITY OR OF FITNESS FOR A PARTICULAR PURPOSE, OR WARRANTY OR GUARANTY OF ANY OTHER KIND, EXPRESS OR IMPLIED, IS MADE REGARDING PERFORMANCE, SAFETY, SUITABILITY, STABILITY OR OTHERWISE. THIS INFORMATION IS NOT INTENDED TO BE ALL-INCLUSIVE AS TO THE MANNER AND CONDITIONS OF CHLORINE USE, HANDLING, STORAGE, DISPOSAL AND OTHER FACTORS THAT MAY INVOLVE OTHER OR ADDITIONAL LEGAL, ENVIRONMENTAL, SAFETY OR PERFORMANCE CONSIDERATIONS, AND OXYCHEM ASSUMES NO LIABILITY WHATSOEVER FOR THE USE OF OR RELIANCE UPON THIS INFORMATION. WHILE OUR TECHNICAL PERSONNEL WILL BE HAPPY TO RESPOND TO QUESTIONS, SAFE HANDLING AND USE OF THE PRODUCT REMAINS THE RESPONSIBILITY OF THE CHLORINE USER. NO SUGGESTIONS FOR USE ARE INTENDED AS, AND NOTHING HEREIN SHALL BE CONSTRUED AS, A RECOMMENDATION TO INFRINGE ANY EXISTING PATENTS OR TO VIOLATE ANY FEDERAL, STATE, LOCAL OR FOREIGN LAWS."**

## THE COMMANDMENTS OF CHLORINE USAGE

- Only properly trained personnel wearing approved personal protective equipment should handle chlorine equipment, piping and containers.
- Every site using chlorine should have an emergency response plan in place that protects both the employees and the community. All employees should receive training on the emergency response plan.
- No one should respond to a chlorine emergency or leak if he or she is not a trained responder or does not have all of the necessary tools, equipment and PPE to respond safely.
- Nitrogen trichloride (NCl<sub>3</sub>) is an unstable compound that can self-detonate at relatively low concentrations. Very small concentrations can detonate with tremendous force. Systems where NCl<sub>3</sub> may accumulate or concentrate must be actively monitored and managed to maintain NCl<sub>3</sub> at safe levels.
- Chlorine will react violently with many different chemicals and materials. It is essential that all equipment, piping and valves be properly cleaned and dried for chlorine service before introducing any chlorine into the system.
- Chlorine will react with many metals, especially at elevated temperatures. It is critical that the material of construction be consistent with the operation conditions and that excessive external heat is not applied to chlorine containing systems.
- Dry chlorine will react violently with titanium. Systems must be in place to protect titanium equipment from exposure to dry chlorine and ensure titanium is not used in dry chlorine service.
- Many grades of carbon steel can become brittle when exposed to temperatures below -20F. It is essential that low-temperature carbon steel or a suitable alloy is used for continuous chlorine operation below -20F.
- Moisture in dry chlorine systems will rapidly increase carbon steel corrosion rates to dangerous levels. The possibility of generating hydrogen also exists. Moisture concentrations must be continuously monitored and controlled using moisture analyzers and drying systems.
- Liquid chlorine has a high coefficient of expansion. Any system where liquid chlorine can be trapped must have expansion protection.



## TABLE OF CONTENTS

History and Growth of Chlorine	<b>5</b>
Production Process	<b>6</b>
Characteristics	<b>7</b>
Chlorine Container—Tank Trucks	<b>8</b>
Chlorine Containers—Rail Cars	<b>9</b>
Handling Equipment	<b>12</b>
Safety and Emergency Information	<b>14</b>
Technical Data	<b>17</b>
Bibliography	<b>29</b>
Chlorine Institute	<b>30</b>

## THE HISTORY AND GROWTH OF CHLORINE

The earliest annals of chemistry mention chlorine compounds. In 77 A.D., Pliny the Elder published one of the first practical collections of chemical reactions. His formula for gold purification generated chlorine as a by-product in the form of hydrogen chloride. But more than 800 years passed before written records showed that Arab cultures had learned to react chlorine with water to produce hydrochloric acid.

Around 1200 A.D., alchemists discovered that a mixture of hydrochloric and nitric acids dissolved gold. This procedure generates chlorine, but there is no record that a heavy greenish gas was evolved. In 1630, Belgian Jean Baptiste van Helmont wrote of a "salt gas" that we know contained chlorine, but it wasn't until 1774 that Swedish apothecary, Carl Wilhelm Scheele, generated, collected, and studied chlorine as an end in itself.

Even Scheele's discovery was nearly accidental. He collected chlorine out of simple curiosity. Perhaps he too would have treated the gas casually if he hadn't, on some impulse, placed some leaves and flowers into a bottle of chlorine. Within minutes the plants had turned white, and man had the first historical record of the bleaching action of chlorine.

Scheele's discovery came when both modern chemistry and the industrial revolution were taking their first halting steps down paths that would soon change the course of history. Antoine Lavoisier, the father of modern chemistry, took note of Scheele's work and quickly became embroiled in a controversy over whether chlorine was an element or a compound. Meanwhile, textile producers in the French town of Javelle heard of the bleaching action of this gas, and in 1789 bubbled it through a potash solution producing *eau de Javelle*, (*Javelle Water*), the first commercial liquid chlorine bleach.

The eruption of the French Revolution cut short the intellectual ferment begun by Lavoisier and his followers. Lavoisier himself was guillotined in 1793, but his chemistry had crossed the English Channel. Once again, scientific curiosity paralleled commercial necessity. Humphry Davy, the English father of electrolysis, demonstrated that chlorine was an element with properties useful to Britain's rapidly expanding textile and paper industries.

In the 1830s Michael Faraday, Davy's lab assistant, produced a definitive work on both

the electrolytic generation of chlorine and the ease of its liquefaction. In 1851, Charles Watt obtained the first English patent for an electrolytic chlorine production cell.

Through the 1880s and 1890s producers in Germany, England, Canada, and the United States refined chlorine technology. Around 1890, German producers learned that, while wet liquid chlorine was almost impossible to package, removal of all water allowed safe shipment in ordinary iron or steel pressure vessels.

In the early 1900s, chlorine was produced in mercury and diaphragm electrolytic cells and shipped in liquid form as a matter of course. A modern chlorine industry had formed. By 1913, the first permanent liquid chlorine water purification system had been installed in Philadelphia. The following year, Altoona, Pennsylvania, became the first city to treat sewage with liquid chlorine.

World War I brought added impetus to North American chlorine production. Submarine warfare practically eliminated imports of chemicals from Europe at a time when markets for many chemicals, including chlorine, were growing rapidly. By the end of the war, the United States had a large and firmly entrenched domestic chlorine industry.

In the 1930s, the world's chemical industry erupted in a period of extraordinary growth that still continues. Bleaching properties of chlorine became just one of its major uses. Its disinfecting properties remained vital to health, but became a minor market for a chemical that would soon affect almost every human activity.

Today, we use chlorine as a raw material in the manufacture of polyvinyl chloride, a plastic used in fabricating flooring, pipe, wallpaper, clothing, furniture, and a wide range of household products. We treat our illnesses with complex drugs and treat our crops with insecticides, herbicides and fungicides that contain chlorine as part of their basic structure. Chlorinated chemicals also enable us to refrigerate and freeze our food, cool our homes, offices and cars, and even insulate our buildings from the heat and cold.

One of the most important uses of chlorine is helping produce chemicals that contain no chlorine at all. Chlorine and chlorine chemicals help promote reactions that produce a host of useful products.

**Production Process**

The basic raw material for the process, salt, comes from either mines or underground wells. Mined salt is dissolved with water to form raw brine. In other cases, water is pumped into salt deposits, forming brine in the earth that is tapped and drawn off from the resulting brine well.

Raw brine contains impurities that interfere with chlorine caustic production. They are removed by chemical treatment, settling, and filtration. The purified brine is pumped to the cell room. The cell room contains one of three types of electrolytic cells for decomposing brine into chlorine, caustic soda or caustic potash, and hydrogen. These three cell types are diaphragm, membrane and mercury cells. OxyChem no longer utilizes mercury cells in the production of chlorine and caustic soda in the United States.

The chlorine that leaves the cell is hot and wet, and very corrosive. It must be cooled and

dried in specially designed equipment before it can be processed in ordinary steel equipment. Additionally, the chlorine stream contains small amounts of air, hydrogen and some carbon dioxide (due to small amounts of carbon bearing chemicals in the brine).

Once the chlorine stream is cooled and dried, compressors and refrigeration machines are used to liquefy the gas. Chlorine is most easily handled as a liquid in specially designed pressure containers.

Any gaseous contaminants in the chlorine stream are removed. Small amounts of chlorine mixed with them are nearly completely recovered. The recovered chlorine is then returned to the liquefaction process.

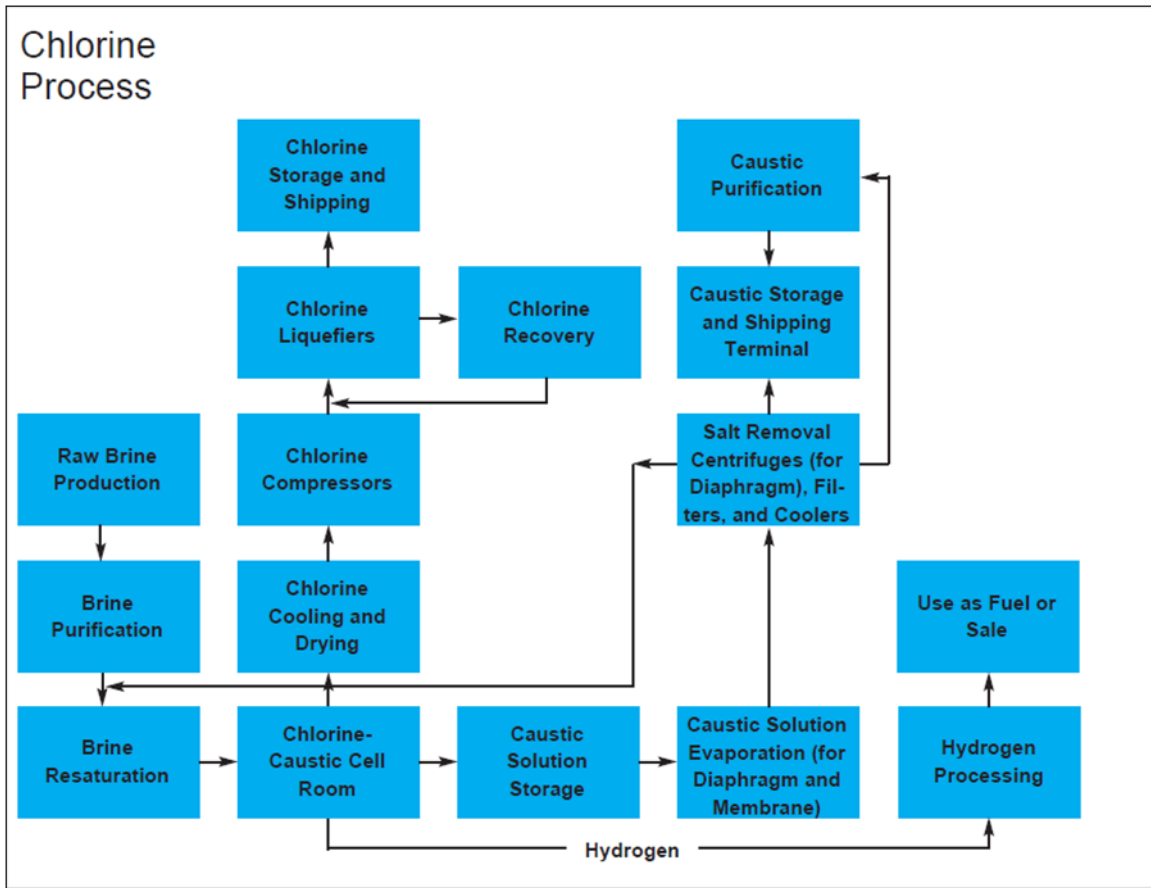

## Characteristics

Chlorine, at ambient conditions of temperature and pressure, is a greenish yellow gas with a pungent and irritating odor. Since chlorine is very active chemically, it is found in nature only in combination with other elements. Sodium chloride, for example, is widely and abundantly distributed in nature and constitutes the chief source of chlorine. Because gaseous chlorine is approximately two-and-one-half times as heavy as air, it is slow to diffuse into the air. It tends to accumulate in low places.

Gaseous chlorine can be liquefied by the application of pressure at reduced temperatures to form a clear, amber-colored liquid. Liquid chlorine is approximately one-and-one-half times as heavy as water.

In the presence of moisture, both gaseous and liquid chlorine are extremely corrosive to common metals of construction. At low pressures, wet chlorine can be handled in equipment made of glass, chemical stoneware, titanium and certain plastics. Installations employing wet chlorine require special care and recommendations can be made only after a thorough and careful investigation. Platinum, tantalum and titanium are some of the metals resistant to moist chlorine.

Dry chlorine, both gaseous and liquid, can be handled safely in equipment fabricated from iron, steel, certain stainless steels, Monel® metal, nickel, copper, brass, bronze and

lead. These metals are not aggressively attacked by dry chlorine but the slightest trace of moisture will cause severe corrosion.

However, dry chlorine attacks metals at elevated temperatures. Chlorine reacts with carbon steel at elevated temperatures. Operations above 250°F should be avoided. Dry chlorine will also react violently with titanium. Titanium should never be used in dry chlorine service.

Since chlorine boils at about -30° F, under certain conditions it can embrittle ordinary carbon steels. If temperatures below -20° F are expected to occur, special carbon steels, or other materials of construction should be considered.

Chlorine is an excellent oxidizing agent, which accounts for its widespread use as a bleaching agent.

Liquid and gaseous chlorine are nonflammable and will not support combustion in the normal sense. However, chlorine will support the combustion of certain materials under special conditions.

Dry chlorine has an extremely high affinity for moisture. Regardless of the environmental conditions of temperature and humidity, all open ends of chlorine pipelines should be closed, moisture tight, when not in use. An open end of a chlorine delivery line will, within a time interval of only a few minutes, pick up sufficient moisture from the atmosphere to cause severe corrosion.



## CHLORINE CONTAINERS



OxyChem supplies chlorine in rail cars to a variety of industries. Occasionally, the chlorine is repackaged into smaller, easier to manage containers depending on the application. Tank trucks, ton containers and cylinders of chlorine may be encountered. Please contact your supplier or the Chlorine Institute for information on the proper handling and use of these containers.





## TANK CARS



OxyChem supplies liquid chlorine in 90-ton rail tank cars. OxyChem's fleet of chlorine tank cars complies with all specifications and regulations of the U.S. Department of Transportation (DOT). Chlorine tank cars are constructed of fusion welded steel, built according to DOT specification 105J500W. The tank is provided with head protection and insulating material which, is protected by a steel jacket. The only opening in the tank is in the dome, which contains all of the valves on the tank. Figure 1 shows typical rail car dimensions.

The two angle valves parallel to the length of the tank car deliver liquid chlorine. The liquid valves are connected to education pipes, which are equipped with excess flow valves. The excess flow valve is designed to stop flow if the angle valve is sheared off the railcar. It is not designed to stop chlorine flow in the event of a ruptured delivery line. The excess flow valves are designed to stop the flow of liquid chlorine if the delivery rate exceeds 15,000 or 32,000 pounds/hour for a 90-ton car. Figure 2 shows a typical tank dome arrangement.

The two angle valves at right angles to the longitudinal axis of the tank car can be used to apply dry air or nitrogen padding. Figure 3 shows the valve arrangement under the tank car dome cover.

The outlet of each angle valve on a tank car has one inch standard tapered female pipe threads. This outlet is protected by a one inch pipe plug which must be kept in place whenever the valve is not in use.

The safety valve is located at the center of the dome. On DOT 105J500W tank cars, the safety valve is designed to initially relieve at a pressure of 375 psig and then it operates as a regular spring-loaded valve set to discharge at 351 psig. Safety valves on chlorine tank cars must never be disturbed or tampered with under any circumstances.

Each time a tank car is returned to OxyChem, it undergoes a thorough inspection. Any damaged tank car is immediately removed from service until repairs can be made.

Midland angle valves are replaced on a routine schedule in accordance to OxyChem's quality standards. The tank car safety valves and excess flow valves are inspected and cleaned at the same time.

Tank cars must be unloaded only on the consumer's protected private track. When a tank car of chlorine is placed on a private siding for unloading, the brakes must be set and the wheels blocked. The following precautions are required by DOT Hazardous Materials Regulation, CFR Title 49, Paragraph 174.67, governing the transportation of hazardous materials: "Caution" signs must be placed in such a position on the track or car to warn persons approaching the car from the open end or ends of the siding and must be left up until after the car is unloaded and disconnected from the discharge connection. Signs must be made of metal and be at least 12 by 15 inches in size and bear

the words “Stop-Car Connected” or “STOP—Men at Work.” The word “STOP” must be in letters at least 4 inches high and the other words in letters at least 2 inches high. The letters must be white on a blue background. Tank cars should be protected by a preferably locked derail at the switch end or ends of a siding and be a minimum of 50 feet away.

Shipping a leaking or defective tank car containing any chlorine is a DOT violation. If a tank car is defective, call your supplier. Oxy-Chem’s 24-hour emergency number is (800) 733-3665.

Use a flexible connection for unloading chlorine as outlined in The Chlorine Institute, Inc. Pam-phlet No. 6 and 57, DWG No. 118.

Opening a liquid chlorine valve too rapidly could cause the excess flow valve to function and stop the flow of liquid chlorine. The excess flow valve can be unchecked by closing the

chlorine valve completely and waiting until a noticeable click is heard, indicating that the metal ball has fallen back into place.

In many chlorine handling systems, additional pressure is necessary for unloading at a normal or accelerated rate. Under these conditions, dry air (dew point of  $< -40^{\circ}\text{F}$ ) must be used. A separate plant air drying system is needed for this operation. Safe padding pressure limits are defined by the setting of the pressure relief valve and the temperature of the liquid chlorine. Padding pressure limits for chlorine tank cars can be found in The Chlorine Institute, Inc., Drawing # 201. For additional information on the handling and use of tank cars refer to The Chlorine Institute, Inc., Pamphlet # 66

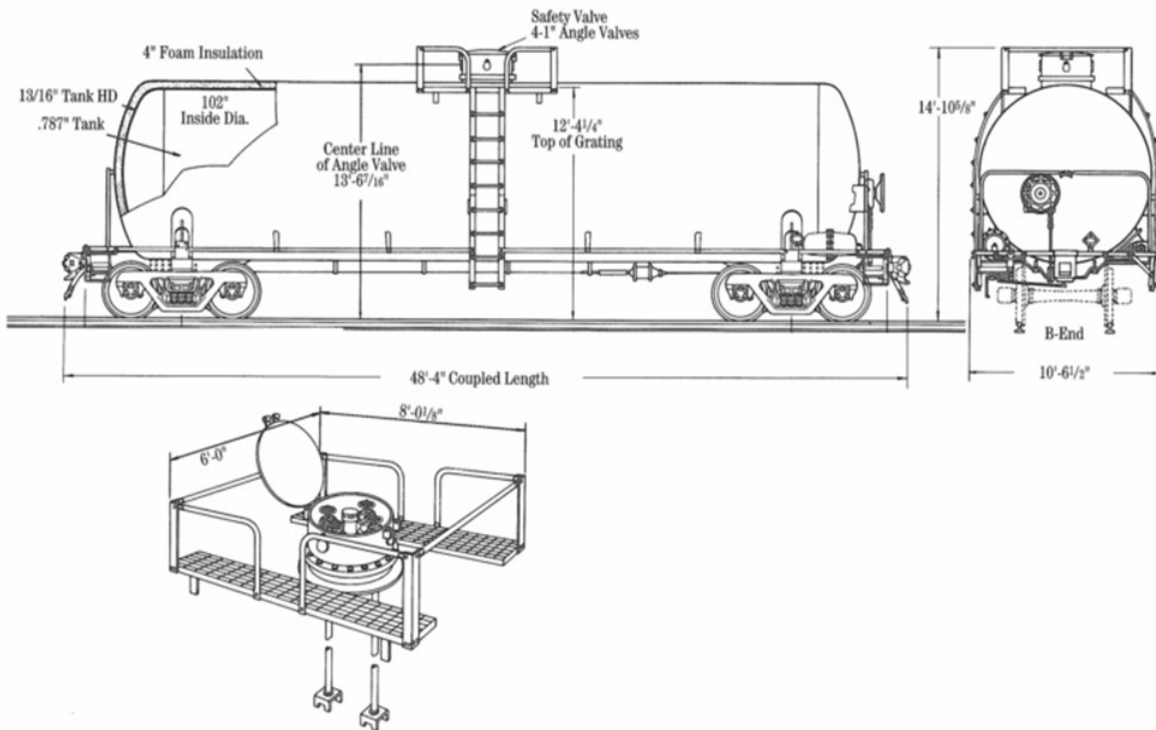

Figure 1 Typical Rail Car Dimensions

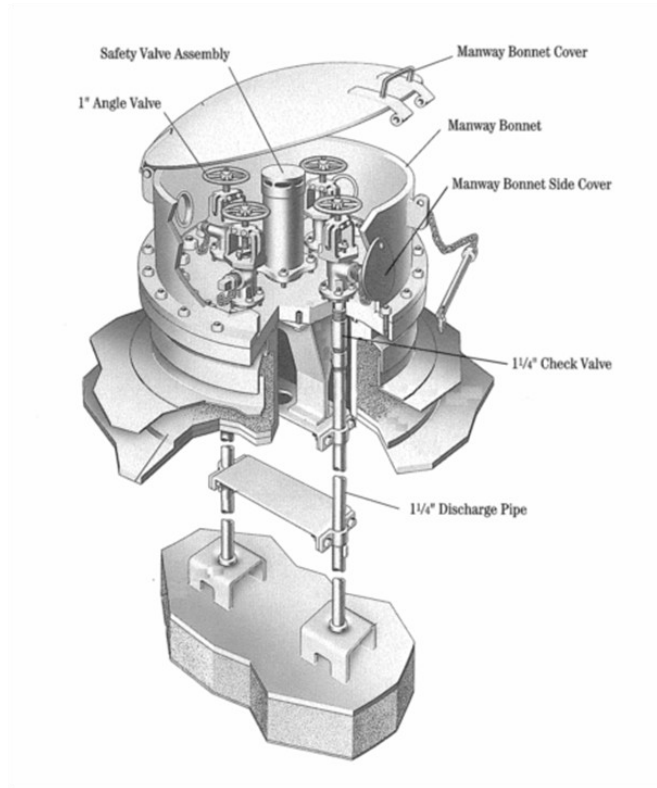

Figure 2 Typical Tank Car Dome Assembly

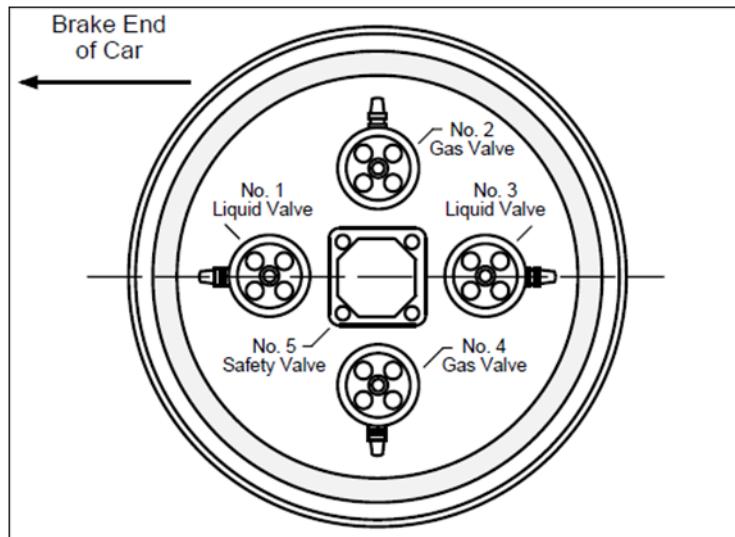

Figure 3 Tank Car Valve Arrangement

### Handling Equipment

In general, pipelines for handling chlorine should be fabricated from extra heavy, black iron pipe. Joints must be welded or flanged. Fittings must be eliminated wherever possible.

Valves used in chlorine service should be manufactured specifically for use with chlorine. For additional information on valves for chlorine service please consult The Chlorine Institute, Inc., Pamphlet # 6.

The use of valves in pipelines must balance minimizing accidental release and reducing fugitive emissions.

Liquid chlorine has a high coefficient of thermal expansion. If liquid chlorine is trapped between two valves, high hydraulic pressure may develop and lead to a rupture of the line or its fittings. Expansion chambers should be installed any place liquid chlorine can be trapped between two valves. Expansion chambers are fabricated from extra heavy pipe and have a capacity equal to at least 20 volume percent of the protected section of pipe.

For more information on piping systems, consult The Chlorine Institute, Inc., Pamphlets # 6 and 60.

Chlorine unloading systems should include an emergency shut off system to remotely isolate both ends of the flexible transfer hose. See The Chlorine Institute, Inc., Pamphlet #57 for additional information.

When large amounts of gaseous chlorine are required for a specific process, it is advisable to remove the chlorine from the manufacturer's container as a liquid and pass it through a vaporizer to convert it to a gas. In this manner,

much more gaseous chlorine can be sent to process than would otherwise be possible. Rapid removal of gaseous chlorine from a container will cool the remaining liquid chlorine to a point where the generation of chlorine vapor will be greatly reduced and little or no chlorine vapor will flow into the process. The use of a vaporizer supplies sufficient heat to the liquid chlorine from an outside source so that the temperature and pressure of the chlorine supply remains relatively constant. For more information on Chlorine Vaporizers, consult The Chlorine Institute, Inc., Pamphlet No. 9

Any liquid passing through a pipeline suffers a loss in pressure due to the resistance to flow offered by the pipeline. A further loss in pressure or head is experienced when the liquid is elevated. For every foot in elevation that liquid chlorine is raised, there is a loss in pressure of about 0.635 psi which should be added to the pressure losses due to the resistance of the piping.

The graph on page 13 shows the calculated pressure drop for liquid chlorine flowing through SCH 80 pipe of various dimensions. When valves and fittings are included in the piping system, the additional pressure loss can be readily computed by converting the friction loss in the valves and fittings to equivalent lengths of straight pipe. The data below can be used to calculate the pressure drop from various types of fittings.

### Equivalent Length of Pipe in Feet

Fitting	1"	¾"	½"
Globe Valve (full open)	28.3	21.3	14.2
Angle Valve (full open)	12.0	9.0	6.0
Standard T (through the branch)	4.8	3.6	2.7
Long Radius Elbow	1.6	1.2	0.9

Taken from the Crane Company Technical Paper No. 409

### Pressure Drop for Liquid Chlorine Flowing in New Steel Pipe

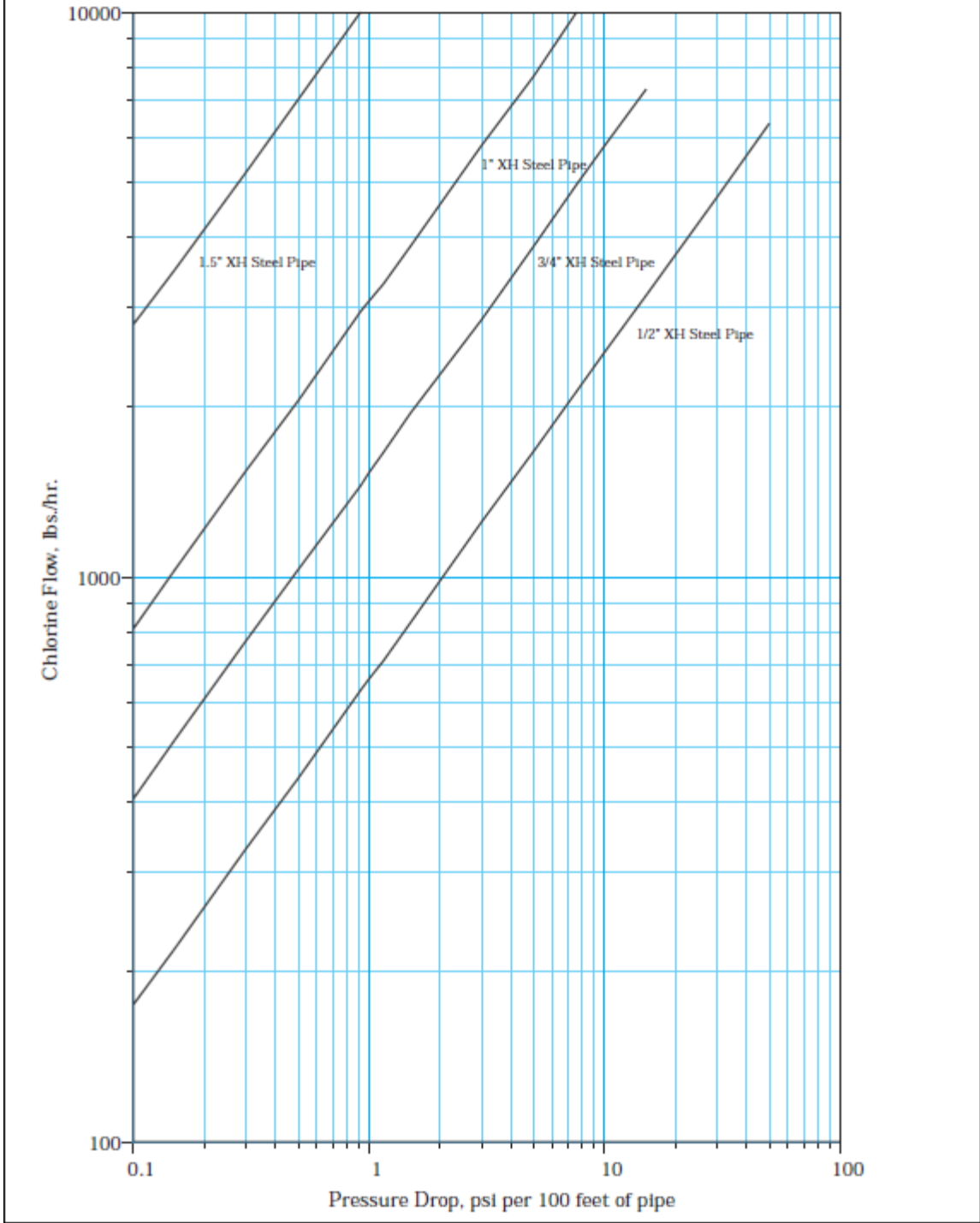

## **Safety and Emergency Information**

*All personnel engaged in handling chlorine must be thoroughly instructed in the necessary precautions for the safe handling, storage and use of chlorine. Carefully study everything in this manual.*

*Read the MSDS before use.*

*Neither the gas nor the liquid alone is explosive or flammable. Both react chemically with many substances, especially at elevated temperatures. The gas is greenish yellow in color at high concentrations. It has a penetrating odor, and is two-and-one-half times as heavy as air. If it escapes from a container or system, it will seek the lowest level in the building or area in which the leak occurs. Training should include the use of safety equipment and first-aid procedures.*

### **Employee Protection**

Do not breathe chlorine vapors. Chlorine irritates the mucous membranes, respiratory tract and eyes. Smoking can aggravate the respiratory symptoms which result from chlorine exposure. Prolonged exposure to the gas causes coughing and gagging, and may result in pulmonary edema and death. Individuals with respiratory problems should consult a physician before working with chlorine.

Avoid contact with eyes, skin and clothing. Gaseous chlorine hydrolyzes in the presence of moisture, forming hydrochloric acid, which irritates the eyes and skin. Liquid chlorine removes body heat, freezing exposed skin. Wash thoroughly after handling chlorine. Shower, using plenty of soap and water.

### **Safety Equipment**

Use goggles, rubber gloves, rubber shoes, hard hat and a NIOSH approved respirator with an acid gas cartridge where airborne concentrations are expected to exceed exposure limits or when symptoms have been observed that are indicative of overexposure. It is essential that each individual who may be exposed to chlorine carry, at all times, a respirator approved for chlorine use. For re-entry into an emergency area, self contained breathing equipment must be used.

### **Ventilation**

Provide adequate ventilation to reduce the accumulation of gaseous chlorine in low areas.

In some cases, natural ventilation may be adequate; in others, artificial ventilation, such as forced air through a system of ducts, must be provided. A one-to-four-minute rate of air change is required in an emergency. Precautions must be taken to avoid discharging chlorine into areas where it can cause damage or personal injury.

### **Eye Wash Fountains and Deluge Showers**

Readily accessible eye wash fountains and deluge showers must be provided in strategic locations wherever chlorine is used. Personnel should test equipment on a routine basis to ensure adequate water flow and temperature.

### **Emergency Respiratory Protection**

Severe exposure to chlorine may occur whenever chlorine is handled or used. Therefore, self-contained positive pressure breathing apparatus, approved for emergency chlorine use, should be located strategically outside chlorine work areas, near entrances and away from contamination. Such equipment shall have a rating of at least 30 minutes use, and be equipped with a low-pressure warning bell. Any person entering a chlorine emergency area must be protected by this respiratory protective equipment.

### **Emergency Kits**

In an emergency involving chlorine cylinders, ton containers, tank cars or barges, kits are available to stop leaks. All chlorine users should have access to the appropriate kits. Chlorine emergency kits are maintained by producers and are located strategically throughout the United States and Canada. In addition, kits can be borrowed in an emergency situation from other chlorine users, distributors and some fire departments.

### **Other Emergency Measures**

The Chlorine Institute, Inc. was formed in 1924 by chlorine producers to promote the safe use of chlorine and to standardize chlorine handling equipment. The Institute also sponsors a mutual assistance program in which trained teams respond to chlorine emergencies on a 24-hour-a-day, 7-day-a-week basis. In the United States, this response program is known as CHLOREP (Chlorine Emergency Plan). CHLOREP can be activated by contacting CHEM-TREC (Chemical Transportation

Emergency Center), at 1-800-424-9300, or by contacting the appropriate CHLOREP team.

Canada is divided into 10 regions with teams available from 13 plant sites as established by TEAP (Transportation Emergency Assistance Plan) of the Canadian Chemical Producers' Association. In Canada, assistance is available by calling either the TEAP regional number or the appropriate response team.

In both the United States and Canada, these teams provide assistance in any chlorine emergency whether a transportation incident or problem at the point of usage. Chlorine users must have the telephone numbers of their response teams readily available for use in chlorine emergency situations.

Chlorine users must accept responsibility for taking all proper precautions to prevent accidents with chlorine. The fact that emergency assistance is available should not encourage carelessness in the use of this chemical.

#### In Case of Fire

Chlorine itself will not burn, but it does act as an oxidizer and supports combustion even in the absence of oxygen. Cool the affected containers with large amounts of water ONLY if the containers are not leaking. Never apply water directly on a chlorine leak. Use any other extinguishing medium appropriate for the surround-

ing fire. Use self-contained breathing apparatus and full protective equipment.

#### Leaks

Do not apply water directly on a chlorine leak. Moisture hydrolyzes chlorine, forming hydrochloric acid which attacks the metal, thus enlarging the leak. If a container is leaking chlorine position the container so the liquid remains inside and allows the gas to vent. The quantity of escaping chlorine is significantly less from a gas than a liquid leak, since one volume of liquid is equal to about 460 volumes of gas. Evacuate the area and keep all personnel upwind of leaks, preferably on high ground.

#### Chemical Neutralization

Absorb chlorine in an alkaline solution (caustic soda, soda ash or hydrated lime) while maintaining an excess of base at all times (see chart below). Destroy resulting hypochlorite by adding sodium bisulfite or treating the basic hypochlorite at 122-158F in the presence of copper, nickel or iron. Control pH at the discharge to sewer or the receiving water and comply with all federal, state, and local regulations.

**Recommended Alkaline Solutions for Absorbing Chlorine**

Size of Chlorine Container (Pounds Net)	100% Caustic Soda		100% Soda Ash		100% Hydrated Lime	
	Pounds	Water (gallons)	Pounds	Water (gallons)	Pounds	Water (gallons)
100	125	60	300	200	115	125
150	188	90	450	300	175	188
2000	2500	1200	5980	4000	2325	2500

\* Slurry must be continuously and vigorously agitated if chlorine is to be absorbed 100%.

## **FIRST AID**

### **Exposure Symptoms**

Liquid chlorine is an inhalation, skin and eye irritant. Prolonged contact can produce burns and possibly frostbite. Liquid chlorine vaporizes to gas in the open atmosphere. At detectable odor levels, the gas will irritate the mucous membranes and respiratory tract. (Detectable odor levels range from 0.3 to 3.0 ppm depending on the individual.) With excessive exposure to chlorine, the individual exhibits excitement, accompanied by restlessness, sneezing and copious salivation. In extreme cases, retching, pulmonary edema and even death may occur.

There are no specific known antidotes for chlorine. Effective medical management is necessary for relief of symptoms with proper treatment. Complete recovery normally occurs.

### **Inhalation**

If adverse effects occur, move to an uncontaminated area. Give artificial respiration if a person is not breathing. If breathing is difficult, humidified oxygen should be administered by qualified personnel. If respiration or pulse has stopped, have a trained person administer Basic Life Support (Cardio-Pulmonary Resuscitation/Automatic External Defibrillator) and CALL EMERGENCY SERVICES IMMEDIATELY.

### **Skin**

Immediately flush contaminated areas with water. Remove contaminated clothing, jewelry and shoes immediately. Do not attempt to remove frozen clothing from frostbitten areas. Wash contaminated areas with soap and water. Thoroughly clean and dry contaminated clothing and shoes before reuse. GET MEDICAL ATTENTION IMMEDIATELY.

### **Eyes**

Immediately flush eyes with a directed stream of water for at least 15 minutes, forcibly holding eyelids apart to ensure complete irrigation of all eye and lid tissues. Washing eyes within several seconds is essential to achieve maximum effectiveness. GET MEDICAL ATTENTION IMMEDIATELY.

### **Ingestion**

Due to its physical properties, swallowing liquid chlorine is extremely unlikely. In such an instance, call a physician immediately.

### **Notes to Physician**

Because there is no known antidote for chlorine gas inhalation, treatment is symptomatic. The effective and immediate relief of symptoms is the primary goal. Steroid therapy, if given early, has been re-

ported effective in preventing pulmonary edema.

## **EMPLOYEE TRAINING FOR SAFE OPERATIONS**

Safety in handling chlorine depends, to a great extent, upon the effectiveness of employee education, proper safety instructions, effective supervision and the use of proper personal protective equipment.

Supervisory personnel are responsible for providing proper instruction and training of employees. Training for all employees should be conducted periodically to reinforce correct methods and to maintain a high degree of competence in handling procedures. All new employees must be trained in handling and using chlorine before operating equipment. Employees should be thoroughly familiar with the hazards that may result from improper handling of chlorine. Each employee should know emergency and first aid measures, and how to use associated equipment.

As a minimum, employee training should include the following:

Instruction with periodic drills regarding the locations, purpose, limitations and use of chlorine emergency kits, firefighting equipment, fire alarms, and shutdown equipment such as valves and switches.

Instruction with periodic drills regarding the locations, purpose, limitations and use of personal protective equipment, both normal and emergency.

Instruction with periodic drills regarding the locations, purpose and use of safety showers, eye washes, or the closest source of water for use in emergencies.

Instruction with periodic drills for specified employees regarding the purpose and use of respiratory first aid equipment.

Instruction on avoiding inhalation of chlorine gas and contact with the liquid. Emphasis should be placed on chlorine's effect on the human body at different exposure levels.

Instruction on procedures for reporting all equipment failures to the proper authority.

Instruction on procedures for conducting inspections before working with equipment and, periodically, during operations. This instruction should include procedures for recognizing leaks and other potential problems.

Instruction on the proper actions to take when leaks occur and procedures for evacuating affected areas.



### Physical Properties of Chlorine

Atomic weight: 35.453  
 Boiling point: -34.05°C (-29.29°F)  
 Freezing point: -100.98°C (-149.76°F)  
 Critical temperature: 144.0°C (291.2°F)  
 Critical pressure: 7711 kPa (76.1 atm, 1118 psi)  
 Critical volume:  $1.745 \times 10^{-3} \text{ m}^3/\text{kg}$  (0.02796 cu ft/lb)  
 Heat of fusion at the melting point:  $6405 \pm 5 \text{ J/mol}$   
 (38.86 Btu/lb)

Viscosity of Chlorine Gas at 1 Atm	
°C	cp.
-30	0.0112
0	0.0126
100	0.0169
200	0.021
300	0.025

Thermal Conductivity of Chlorine Gas at 1 Atm	
°C	Btu/(hr-ft-°F)
-30	0.0042
0	0.0048
100	0.0067
200	0.0086
300	0.0103

Thermal Conductivity of Liquid Chlorine	
°C	Btu/(hr-ft-°F)
-100	0.1149
0	0.0847
100	0.0532
144	0.0230

### Conversion of Units

Physical Quantity	SI Unit	Conversion
Concentration	kilograms per cubic meter	$1 \text{ kg/m}^3 = 0.008345 \text{ lbs/gal}$
Density	kilograms per cubic meter	$1 \text{ kg/m}^3 = 0.062428 \text{ lbs/cu ft}$
Energy	joules per kilogram	$1 \text{ J/kg} = 0.000430 \text{ Btu/lb}$
Entropy	joules per kilogram-Kelvin	$1 \text{ J/kg-}^\circ\text{K} = 0.000239 \text{ Btu/lb-}^\circ\text{F}$
Pressure	Pascals (Newtons per square meter)	$1 \text{ Pa} = 0.000145 \text{ psi}$ $1 \text{ Pa} = 9.86923 \times 10^{-6} \text{ atm}$
Surface Tension	joules per square meter	$1 \text{ J/m}^2 = 0.068522 \text{ lb(force)/ft}$ $1 \text{ J/m}^2 = 1000 \text{ ergs/cm}^2$
Temperature	Kelvin	$^\circ\text{K} = ^\circ\text{C} + 273.15$ $^\circ\text{C} = (^\circ\text{F} - 32) / 1.8$
Thermal Conductivity	watts per meter-Kelvin	$1 \text{ W/m-}^\circ\text{K} = 0.577797 \text{ Btu/(hr-ft-}^\circ\text{F)}$
Viscosity	Pascal-second	$1 \text{ Pa-s} = 0.671969 \text{ lb/ft-sec}$ $1 \text{ Pa-s} = 1000 \text{ centipoise}$
Volume	cubic meters per kilogram	$1 \text{ m}^3/\text{kg} = 16.0185 \text{ cu ft/lb}$

## Thermodynamic Properties of Saturated Chlorine

(Base:  $h = 0, s = 0$  for solid  $Cl_2$  at  $0^\circ R$ )

Temp (°F)	Absolute Pressure (psi)	Volume (cu ft/lb)		Enthalpy (Btu/lb)			Entropy (Btu/lb-°R)		
		Liquid	Vapor	Liquid	Vaporization	Vapor	Liquid	Vaporization	Vapor
t	p	$v_l$	$v_g$	$h_l$	$h$	$h_g$	$s_l$	$s$	$s_g$
-130	0.51902	0.0093981	95.993	78.488	137.13	215.57	0.37472	0.41593	0.79065
-120	0.80251	0.0094727	63.930	80.890	135.72	216.61	0.38201	0.39956	0.78158
-110	1.2055	0.0095492	43.776	83.305	134.35	217.65	0.38901	0.38420	0.77322
-100	1.7643	0.0096277	30.738	85.697	133.00	218.69	0.39575	0.36976	0.76551
-90	2.5213	0.0097083	22.081	88.067	131.66	219.73	0.40225	0.35615	0.75840
-80	3.5258	0.0097911	16.193	90.420	130.34	220.78	0.40852	0.34328	0.75181
-70	4.8336	0.0098761	12.101	92.759	129.02	221.78	0.41459	0.33110	0.74570
-60	6.5073	0.0099636	9.1996	95.087	127.71	222.80	0.42048	0.31954	0.74003
-50	8.6157	0.010053	7.1037	97.406	126.40	223.81	0.42620	0.30854	0.73474
-40	11.234	0.010146	5.5642	99.719	125.08	224.80	0.43177	0.29805	0.72982
-30	14.443	0.010242	4.4156	102.02	123.76	225.79	0.43719	0.28802	0.72522
-29.29	14.696	0.010248	4.3457	102.19	123.66	225.86	0.43757	0.28732	0.72490
-20	18.329	0.010340	3.5462	104.33	122.41	226.75	0.44248	0.27842	0.72090
-10	22.984	0.010442	2.8793	106.64	121.05	227.70	0.44765	0.26920	0.71686
0	28.504	0.010547	2.3613	108.95	119.67	228.63	0.45271	0.26033	0.71305
10	34.987	0.010656	1.9544	111.27	118.26	229.53	0.45767	0.25179	0.70946
20	42.538	0.010768	1.6313	113.59	116.82	230.41	0.46252	0.24354	0.70606
30	51.265	0.010885	1.3722	115.92	115.34	231.26	0.46729	0.23555	0.70284
40	61.276	0.011006	1.1625	118.25	113.83	232.09	0.47196	0.22781	0.69978
50	72.684	0.011132	0.99128	120.59	112.28	232.88	0.47656	0.22029	0.69686
60	85.606	0.011263	0.85030	122.95	110.68	233.63	0.48109	0.21297	0.69406
70	100.15	0.011399	0.73335	125.32	109.02	234.35	0.48555	0.20583	0.69138
80	116.45	0.011541	0.63565	127.71	107.31	235.02	0.48994	0.19885	0.68879
90	134.63	0.011690	0.55346	130.11	105.54	235.65	0.49428	0.19200	0.68629
100	154.80	0.011846	0.48388	132.53	103.70	236.23	0.49857	0.18528	0.68385
110	177.09	0.012009	0.42462	134.98	101.78	236.76	0.50281	0.17866	0.68148
120	201.64	0.012181	0.37386	137.45	99.782	237.24	0.50702	0.17213	0.67915
130	228.57	0.012362	0.33014	139.96	97.685	237.65	0.51121	0.16565	0.67686
140	258.03	0.012554	0.29228	142.51	95.483	237.99	0.51537	0.15922	0.67459
150	290.14	0.012758	0.25934	145.09	93.162	238.26	0.51953	0.15280	0.67233
160	325.05	0.012975	0.23052	147.73	90.709	238.44	0.52368	0.14637	0.67006
170	362.91	0.013208	0.20520	150.43	88.105	238.54	0.52786	0.13991	0.66778
180	403.86	0.013458	0.18285	153.20	85.328	238.53	0.53206	0.13339	0.66545
190	448.07	0.013728	0.16301	156.06	82.354	238.41	0.53631	0.12676	0.66307
200	495.68	0.014023	0.14533	159.01	79.150	238.16	0.54063	0.11998	0.66061
210	546.88	0.014348	0.12947	162.07	75.677	237.75	0.54504	0.11300	0.65805
220	601.82	0.014710	0.11518	165.28	71.882	237.16	0.54958	0.10575	0.65534
230	660.70	0.015118	0.10221	168.66	67.696	236.36	0.55428	0.098155	0.65243
240	723.69	0.015587	0.090340	172.25	63.022	235.28	0.55919	0.090072	0.64926
250	790.99	0.016143	0.079352	176.13	57.713	233.84	0.56440	0.081322	0.64573
260	862.81	0.016827	0.069011	180.38	51.528	231.90	0.57004	0.071598	0.64164
270	939.35	0.017729	0.059995	185.19	44.007	229.20	0.57635	0.060310	0.63686
280	1020.8	0.019102	0.049647	191.04	33.987	225.03	0.58393	0.045948	0.62987
290	1107.5	0.022862	0.034207	200.80	14.060	214.86	0.59658	0.018756	0.61534
291.2	1118.37	0.027960	0.027960	207.77	00.000	207.77	0.60582	0.000000	0.60582

REF: Kapoor, R.M.; Martin, J.J., Thermodynamic Properties of Chlorine, Engineering Research Institute, University of Michigan, Ann Arbor, Michigan (1957).

**Thermodynamic Properties of Superheated Chlorine**

v, volume (cu ft/lb); h, enthalpy (Btu/lb); s, entropy (Btu/lb-R)      Figures in parenthesis under the pressures are the saturation temperatures  
 Base: h = 0, s = 0 for solid Cl<sub>2</sub> at 0°F

Temp. (°F)	10 psf (-44.4°F)			14.696 psf (-29.3°F)			20 psf (-16.2°F)			25 psf (-6.1°F)		
	v	h	s	v	h	s	v	h	s	v	h	s
0	6.8782	229.30	0.74326	4.6552	229.13	0.73226	3.3996	228.94	0.72338	2.7036	228.76	0.71689
25	7.2623	232.10	0.74919	4.9185	231.94	0.73822	3.5948	231.77	0.72937	2.8610	231.60	0.72291
50	7.6458	234.92	0.75488	5.1812	234.78	0.74392	3.7892	234.61	0.73510	3.0178	234.45	0.72866
75	8.0288	237.77	0.76033	5.4434	237.63	0.74939	3.9832	237.48	0.74058	3.1739	237.33	0.73416
100	8.4113	240.63	0.76556	5.7050	240.51	0.75464	4.1766	240.36	0.74585	3.3296	240.22	0.73945
125	8.7934	243.52	0.77060	5.9663	243.40	0.75969	4.3697	243.26	0.75092	3.4849	243.13	0.74453
150	9.1752	246.42	0.77546	6.2273	246.30	0.76456	4.5624	246.17	0.75590	3.6398	246.05	0.74942
175	9.5567	249.33	0.78015	6.4879	249.23	0.76925	4.7548	249.10	0.76051	3.7944	248.98	0.75414
200	9.9380	252.27	0.78468	6.7483	252.16	0.77380	4.9469	252.05	0.76506	3.9487	251.94	0.75870
225	10.319	255.21	0.78907	7.0084	255.12	0.77819	5.1388	255.00	0.76946	4.1028	254.90	0.76311
250	10.699	258.17	0.79331	7.2684	258.08	0.78246	5.3305	257.97	0.77372	4.2566	257.87	0.76738
275	11.080	261.15	0.79743	7.5281	261.06	0.78657	5.5220	260.96	0.77785	4.4103	260.86	0.77151
300	11.460	264.13	0.80142	7.7877	264.04	0.79057	5.7133	263.95	0.78175	4.5638	263.86	0.77553
325	11.841	267.12	0.80530	8.0472	267.04	0.79445	5.9045	266.95	0.78574	4.7172	266.86	0.77942
350	12.221	270.13	0.80907	8.3065	270.05	0.79822	6.0956	269.96	0.78952	4.8704	269.88	0.78320
375	12.601	273.14	0.81273	8.5656	273.06	0.80189	6.2865	272.98	0.79319	5.0235	272.90	0.78687
400	12.981	276.15	0.81629	8.8247	276.08	0.80545	6.4773	276.00	0.79676	5.1765	275.92	0.79045

Temp. (°F)	30 psf (2.4°F)			35 psf (10.0°F)			40 psf (16.8°F)			45 psf (23.0°F)		
	v	h	s	v	h	s	v	h	s	v	h	s
25	2.3717	231.43	0.71759	2.0222	231.25	0.71306	1.7600	231.08	0.70910	1.5559	230.90	0.70558
50	2.5034	234.30	0.72336	2.1358	234.14	0.71885	1.8501	233.97	0.71492	1.5456	233.81	0.71142
75	2.6343	237.18	0.72889	2.2489	237.03	0.72440	1.9597	236.88	0.72048	1.7348	236.73	0.71701
100	2.7648	240.08	0.73419	2.3614	239.94	0.72972	2.0588	239.80	0.72582	1.8234	239.66	0.72236
125	2.8949	242.99	0.73928	2.4735	242.86	0.73483	2.1574	242.73	0.73094	1.9115	242.60	0.72750
150	3.0246	245.92	0.74419	2.5852	245.80	0.73974	2.2556	245.67	0.73588	1.9993	245.55	0.73245
175	3.1540	248.87	0.74892	2.6966	248.75	0.74449	2.3535	248.63	0.74063	2.0867	248.51	0.73721
200	3.2831	251.82	0.75349	2.8077	251.71	0.74906	2.4512	251.60	0.74522	2.1738	251.49	0.74181
225	3.4120	254.79	0.75791	2.9186	254.69	0.75349	2.5486	254.58	0.74965	2.2607	254.47	0.74625
250	3.5407	257.77	0.76218	3.0293	257.67	0.75777	2.6457	257.57	0.75394	2.3474	257.47	0.75055
275	3.6692	260.76	0.76632	3.1398	260.67	0.76192	2.7427	260.57	0.75810	2.4339	260.47	0.75471
300	3.7975	263.76	0.77034	3.2501	263.57	0.76584	2.8395	263.58	0.76213	2.5201	263.49	0.75875
325	3.9256	266.77	0.77424	3.3602	266.59	0.76985	2.9361	266.60	0.76603	2.6063	266.51	0.76266
350	4.0536	269.79	0.77802	3.4702	269.71	0.77364	3.0326	269.62	0.76983	2.6923	269.54	0.76646
375	4.1815	272.82	0.78170	3.5801	272.74	0.77732	3.1290	272.66	0.77352	2.7782	272.58	0.77015
400	4.3093	275.85	0.78528	3.6898	275.77	0.78090	3.2253	275.69	0.77710	2.8639	275.62	0.77374

Temp. (°F)	50 psf (29.6°F)			60 psf (38.8°F)			70 psf (47.7°F)			80 psf (55.8°F)		
	v	h	s	v	h	s	v	h	s	v	h	s
50	1.4740	233.65	0.70827	1.2163	233.31	0.70276	1.0321	232.97	0.69803	--	--	--
75	1.5547	236.57	0.71388	1.2846	236.26	0.70841	1.0915	235.95	0.70373	0.9465	235.62	0.69961
100	1.6350	239.51	0.71925	1.3523	239.22	0.71382	1.1503	238.93	0.70917	0.9987	238.63	0.70510
125	1.7148	242.46	0.72441	1.4196	242.19	0.71901	1.2086	241.91	0.71440	1.0503	241.63	0.71035
150	1.7941	245.42	0.72936	1.4864	245.17	0.72399	1.2665	244.91	0.71941	1.1015	244.65	0.71540
175	1.8732	248.39	0.73414	1.5529	248.15	0.72879	1.3240	247.91	0.72423	1.1523	247.66	0.72025
200	1.9519	251.37	0.73875	1.6190	251.15	0.73342	1.3812	250.92	0.72889	1.2028	250.68	0.72492
225	2.0303	254.37	0.74320	1.6850	254.15	0.73789	1.4382	253.93	0.73337	1.2530	253.71	0.72942
250	2.1087	257.37	0.74751	1.7507	257.16	0.74221	1.4949	256.96	0.73771	1.3030	256.75	0.73378
275	2.1868	260.38	0.75168	1.8161	260.18	0.74640	1.5514	259.99	0.74191	1.3528	259.79	0.73799
300	2.2647	263.40	0.75572	1.8814	263.21	0.75046	1.6077	263.03	0.74597	1.4023	262.84	0.74207
325	2.3424	266.42	0.75964	1.9466	266.25	0.75438	1.6638	266.07	0.74991	1.4517	265.89	0.74602
350	2.4200	269.46	0.76344	2.0116	269.29	0.75820	1.7198	269.12	0.75374	1.5010	268.95	0.74986
375	2.4975	272.50	0.76714	2.0764	272.33	0.76190	1.7757	272.17	0.75745	1.5501	272.01	0.75358
400	2.5748	275.54	0.77073	2.1412	275.39	0.76550	1.8315	275.23	0.76106	1.5991	275.08	0.75720

Temp. (°F)	90 psf (63.1°F)			100 psf (69.9°F)			125 psf (84.8°F)			150 psf (97.7°F)		
	v	h	s	v	h	s	v	h	s	v	h	s
75	0.83371	235.30	0.69592	0.74329	234.96	0.69258	--	--	--	--	--	--
100	0.89072	238.32	0.70146	0.79521	238.02	0.69816	0.61574	237.23	0.69100	0.50165	236.40	0.68493
125	0.92717	241.35	0.70675	0.82855	241.07	0.70349	0.65075	240.33	0.69643	0.53187	239.57	0.69048
150	0.97317	244.38	0.71182	0.87041	244.11	0.70859	0.68522	243.43	0.70162	0.56150	242.73	0.69576
175	1.01871	247.41	0.71670	0.91186	247.16	0.71349	0.71925	246.53	0.70659	0.59063	245.87	0.70081
200	1.0640	250.45	0.72139	0.95298	250.22	0.71821	0.75291	249.62	0.71137	0.61936	249.00	0.70566
225	1.1090	253.49	0.72592	0.99380	253.27	0.72275	0.78625	252.71	0.71597	0.64775	252.13	0.71031
250	1.1538	256.54	0.73029	1.03437	256.33	0.72714	0.81932	255.80	0.72040	0.67584	255.26	0.71479
275	1.1983	259.59	0.73452	1.07471	259.39	0.73139	0.85215	258.89	0.72468	0.70369	258.38	0.71912
300	1.2426	262.65	0.73861	1.11487	262.46	0.73549	0.88478	261.98	0.72883	0.73132	261.50	0.72329
325	1.2868	265.71	0.74257	1.15485	265.53	0.73947	0.91723	265.08	0.73283	0.75877	264.62	0.72734
350	1.3308	268.78	0.74642	1.19467	268.61	0.74333	0.94952	268.17	0.73672	0.78604	267.74	0.73125
375	1.3747	271.85	0.75015	1.23436	271.68	0.74707	0.98167	271.27	0.74049	0.81317	270.86	0.73504
400	1.4184	274.92	0.75378	1.27393	274.75	0.75071	1.0136	274.37	0.74414	0.84017	273.97	0.73872

Temp. (°F)	200 psf (119.4°F)			300 psf (162.9°F)			400 psf (179.1°F)			500 psf (200.9°F)		
	v	h	s	v	h	s	v	h	s	v	h	s
150	0.40616	241.25	0.68610	0.24844	237.90	0.67098	--	--	--	--	--	--
175	0.42934	244.60	0.69133	0.26630	241.48	0.67674	--	--	--	--	--	--
200	0.45202	247.73	0.69633	0.28338	244.97	0.68213	0.19729	241.80	0.67069	--	--	--
225	0.47430	250.95	0.70111	0.29987	248.40	0.68723	0.21139	245.55	0.67627	0.15684	242.26	0.66655
250	0.49625	254.14	0.70570	0.31590	251.78	0.69209	0.22479	249.19	0.68149	0.16913	246.28	0.67231
275	0.51792	257.33	0.71011	0.33155	255.12	0.69672	0.23767	252.74	0.68641	0.18064	250.13	0.67764
300	0.53934	260.51	0.71437	0.34690	258.44	0.70116	0.25015	256.23	0.69109	0.19158	253.85	0.68262
325	0.56055	263.68	0.71847	0.36199	261.74	0.70543	0.26230	259.68	0.69555	0.20211	257.48	0.68733
350	0.58160	266.85	0.72245	0.37687	265.01	0.70954	0.27419	263.08	0.69982	0.21230	261.05	0.69180
375	0.60247	270.01	0.72629	0.39155	268.27	0.71350	0.28585	266.46	0.70393	0.22222	264.56	0.69608
400	0.62321	273.17	0.73002	0.40607	271.52	0.71734	0.29732	269.81	0.70788	0.23192	268.03	0.70017

REF: Kapor, R.M.; Martin, J.J., "Thermodynamic Properties of Chlorine, Engineering Research Institute, University of Michigan, Ann Arbor, Michigan (1957).

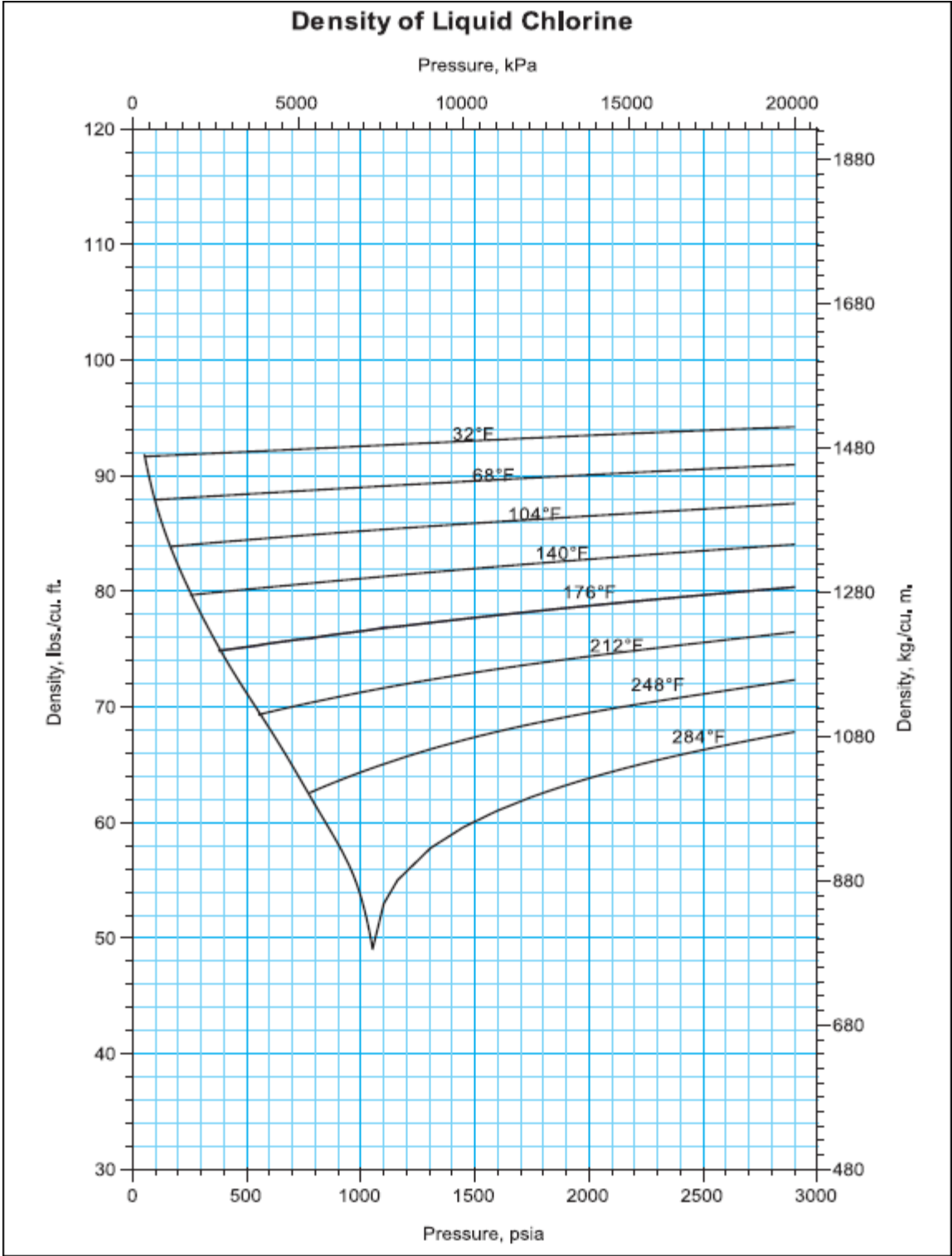

### Specific Heat (Heat Capacity) of Liquid Chlorine

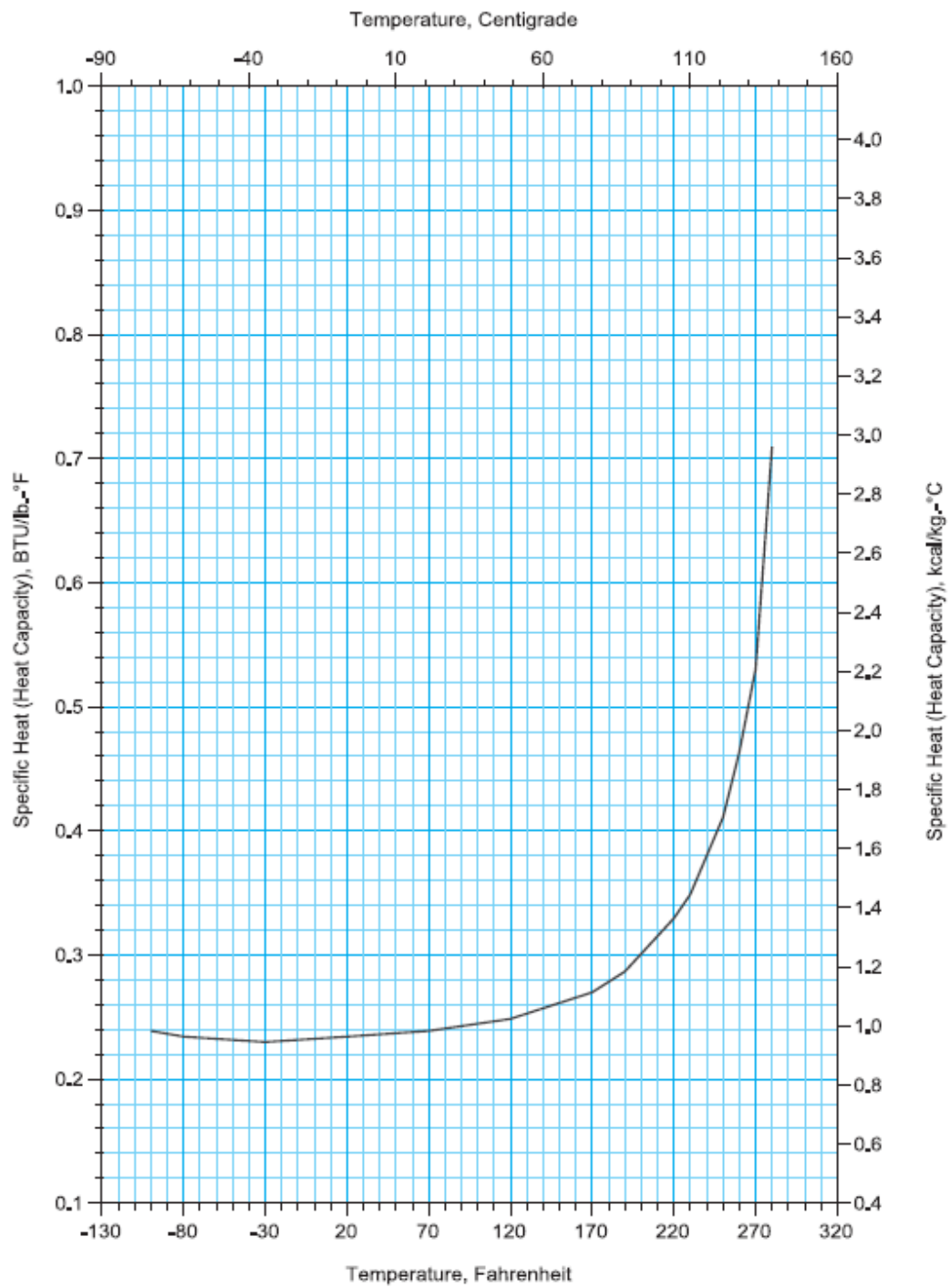

### Specific Heat (Heat Capacity) of Chlorine Gas

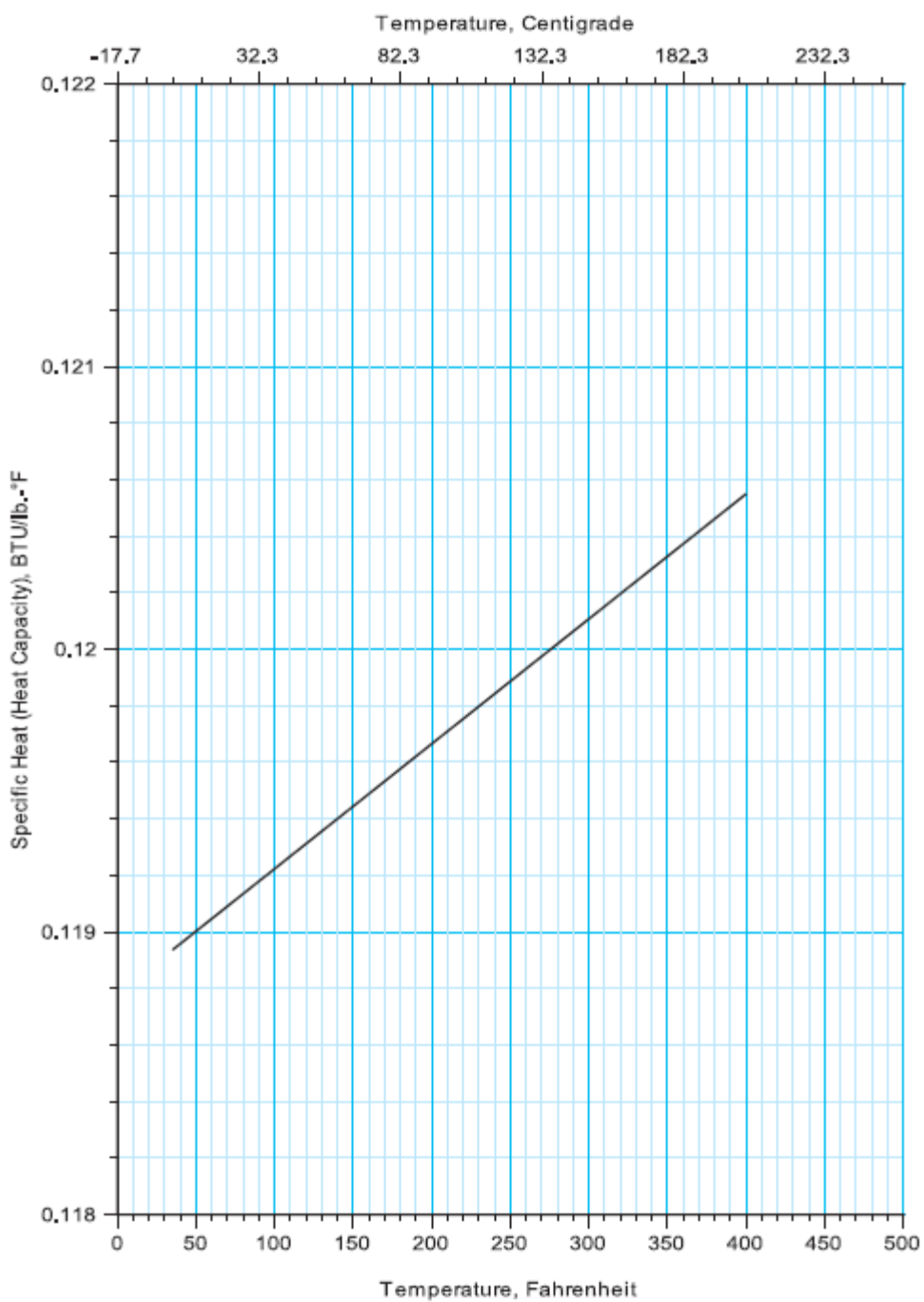

# Latent Heat of Vaporization of Chlorine

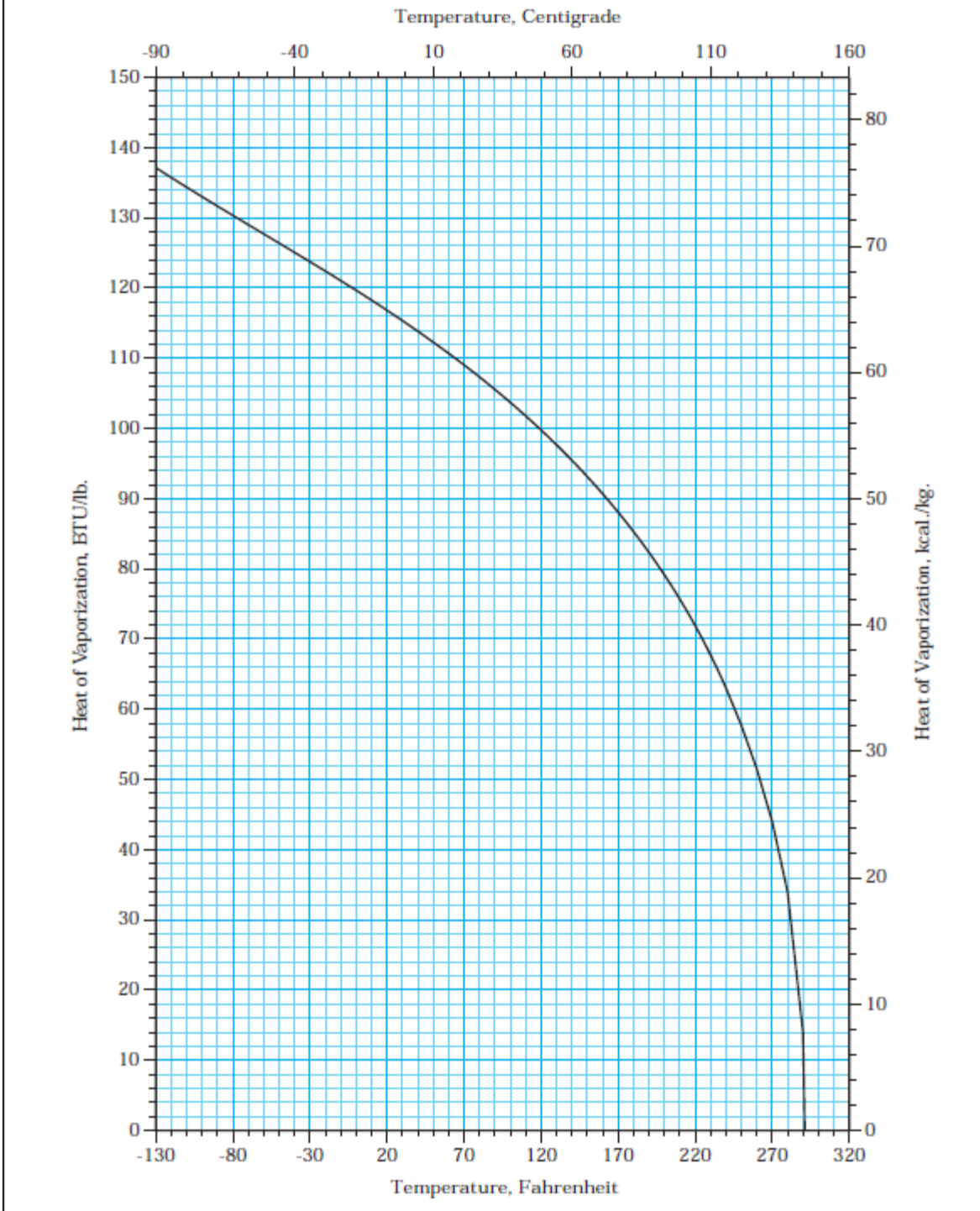

# Solubility of Chlorine in Water

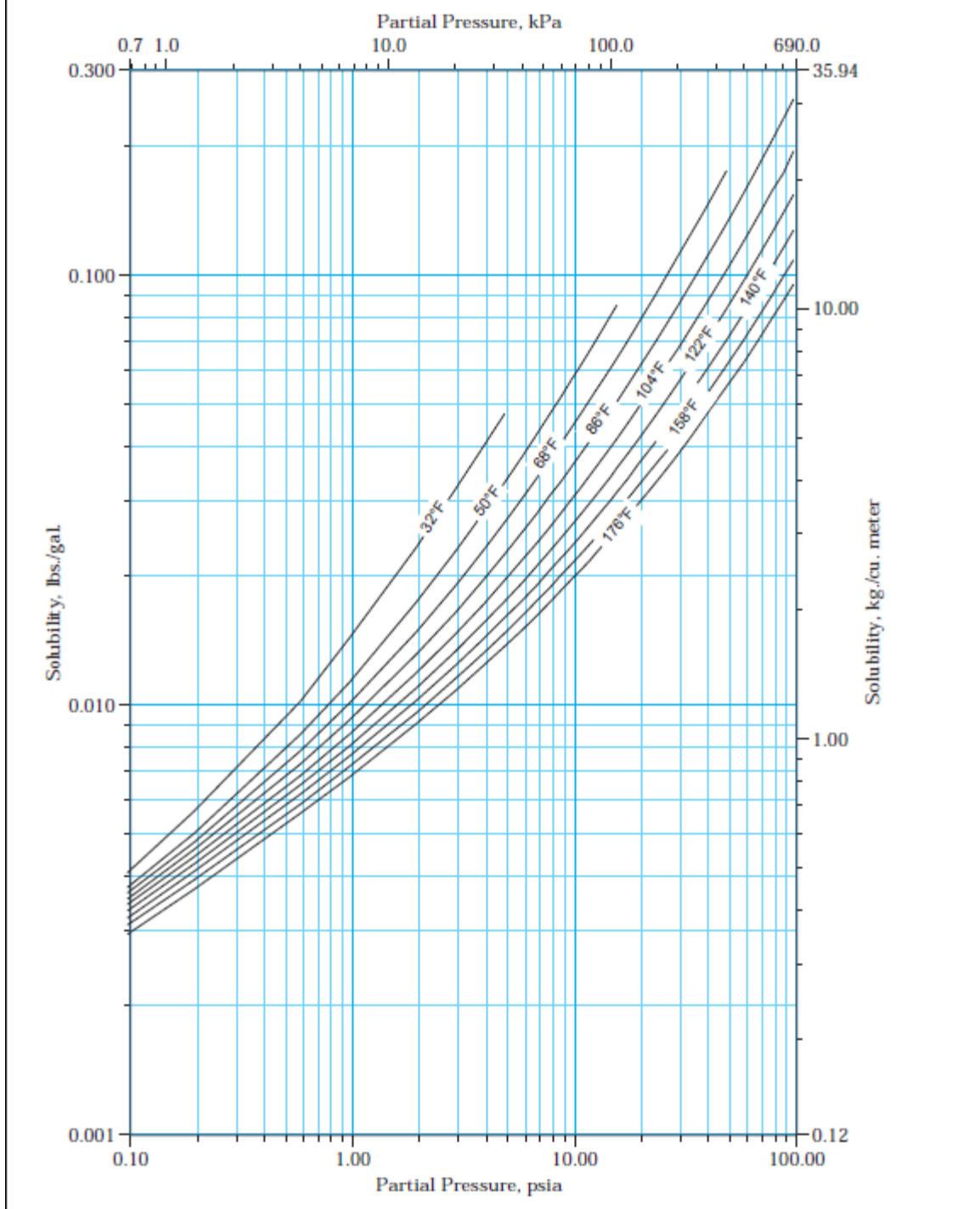



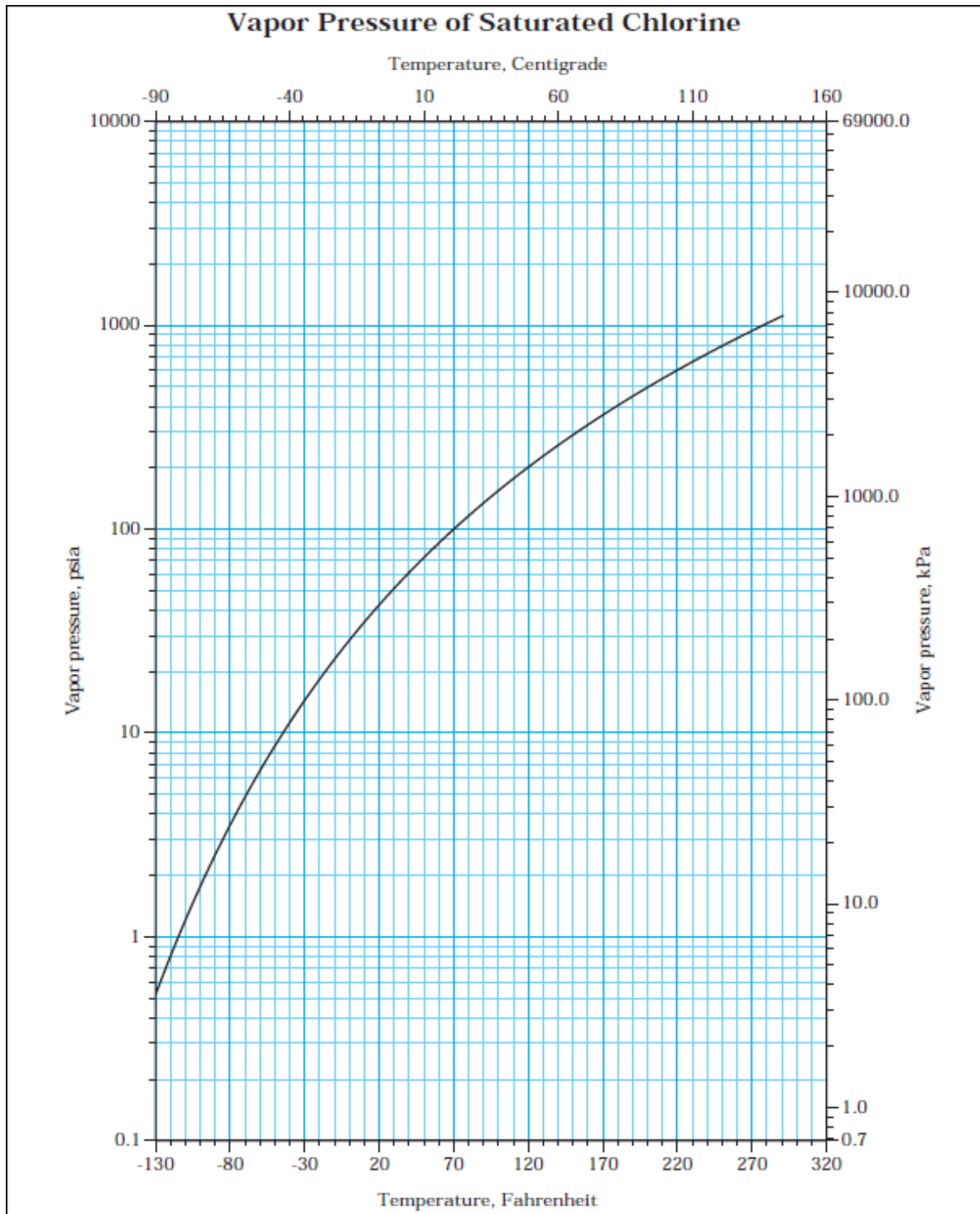

# Viscosity of Liquid Chlorine

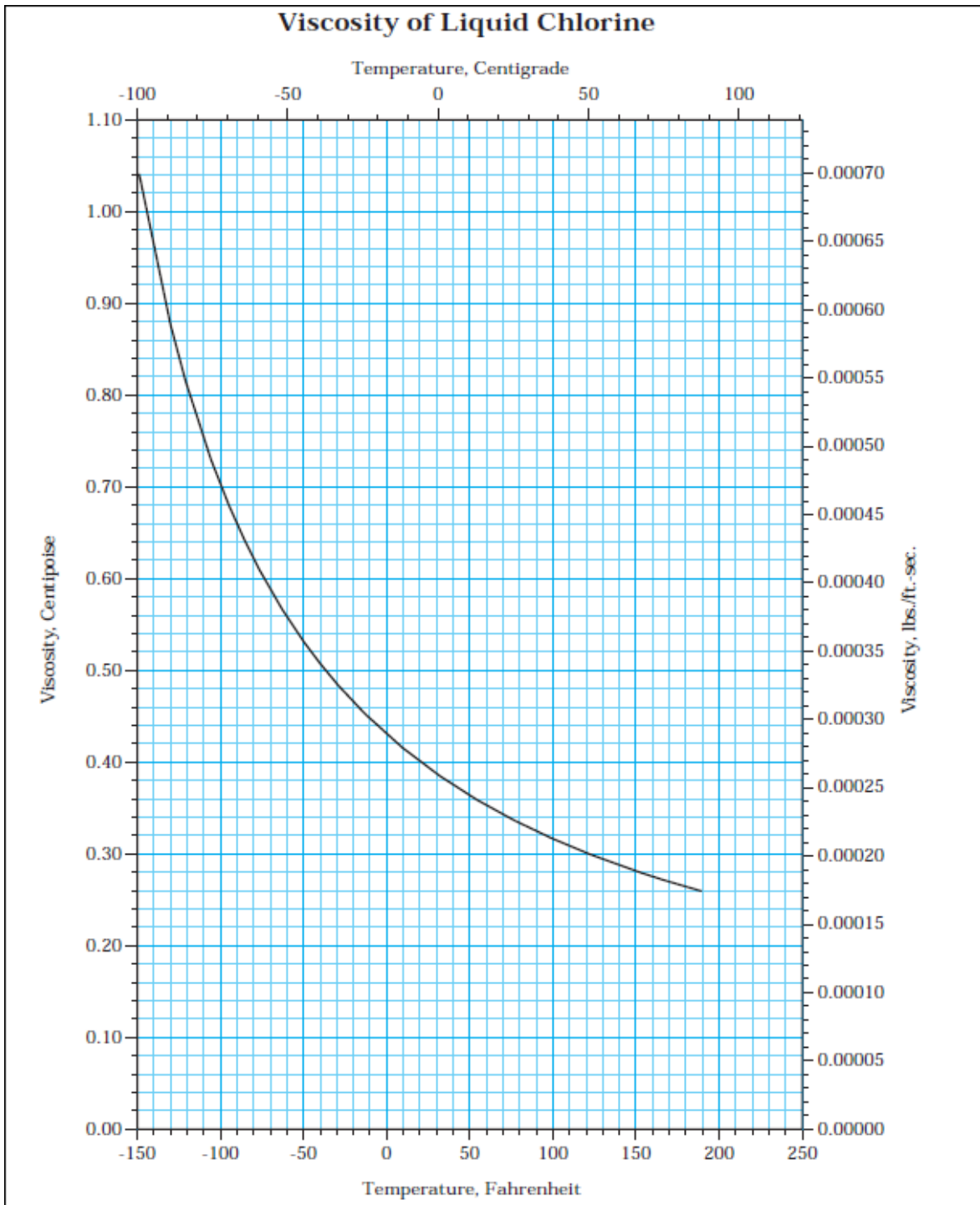

### Viscosity of Chlorine Gas

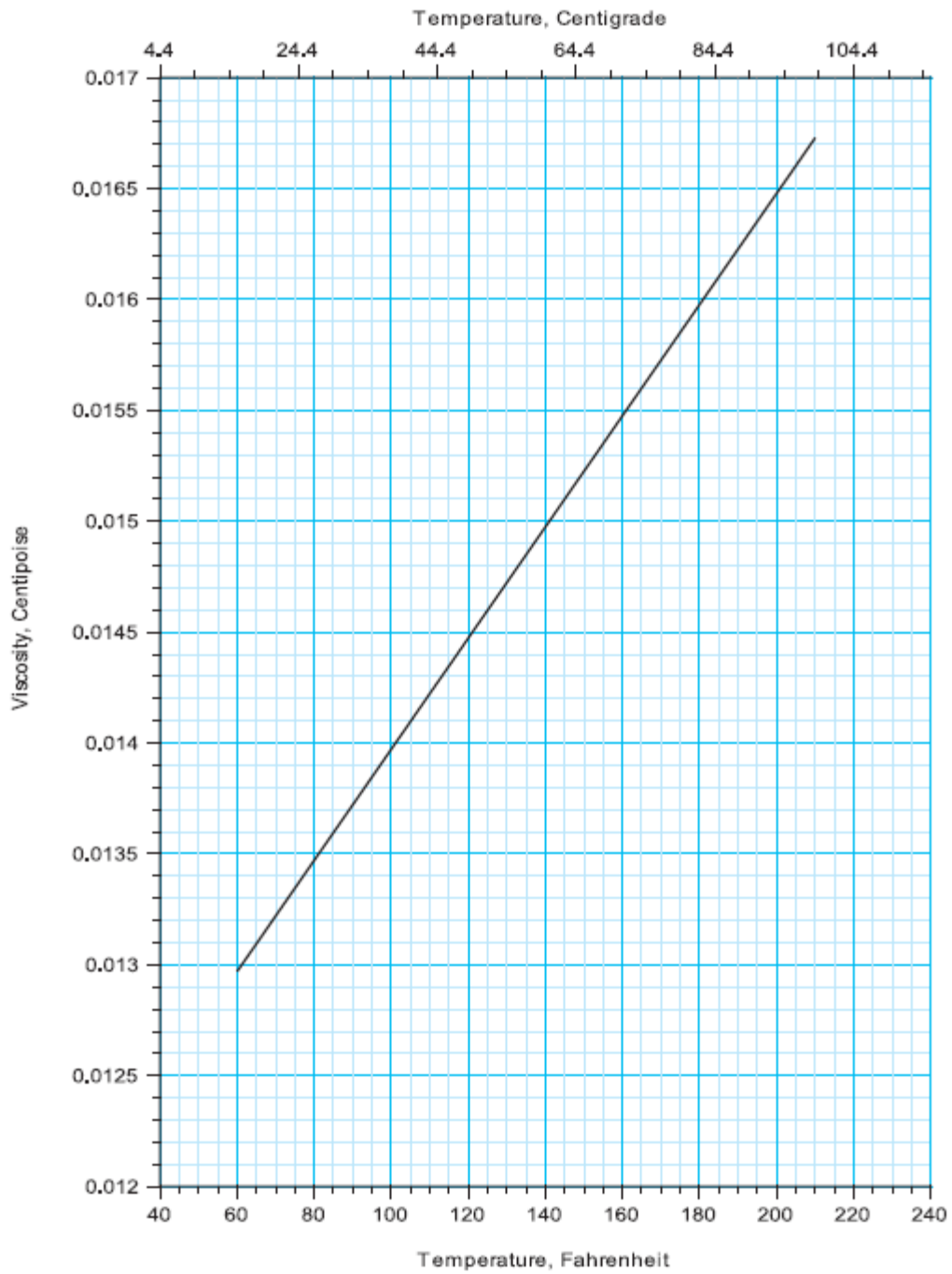

# Enthalpy of Liquid Chlorine

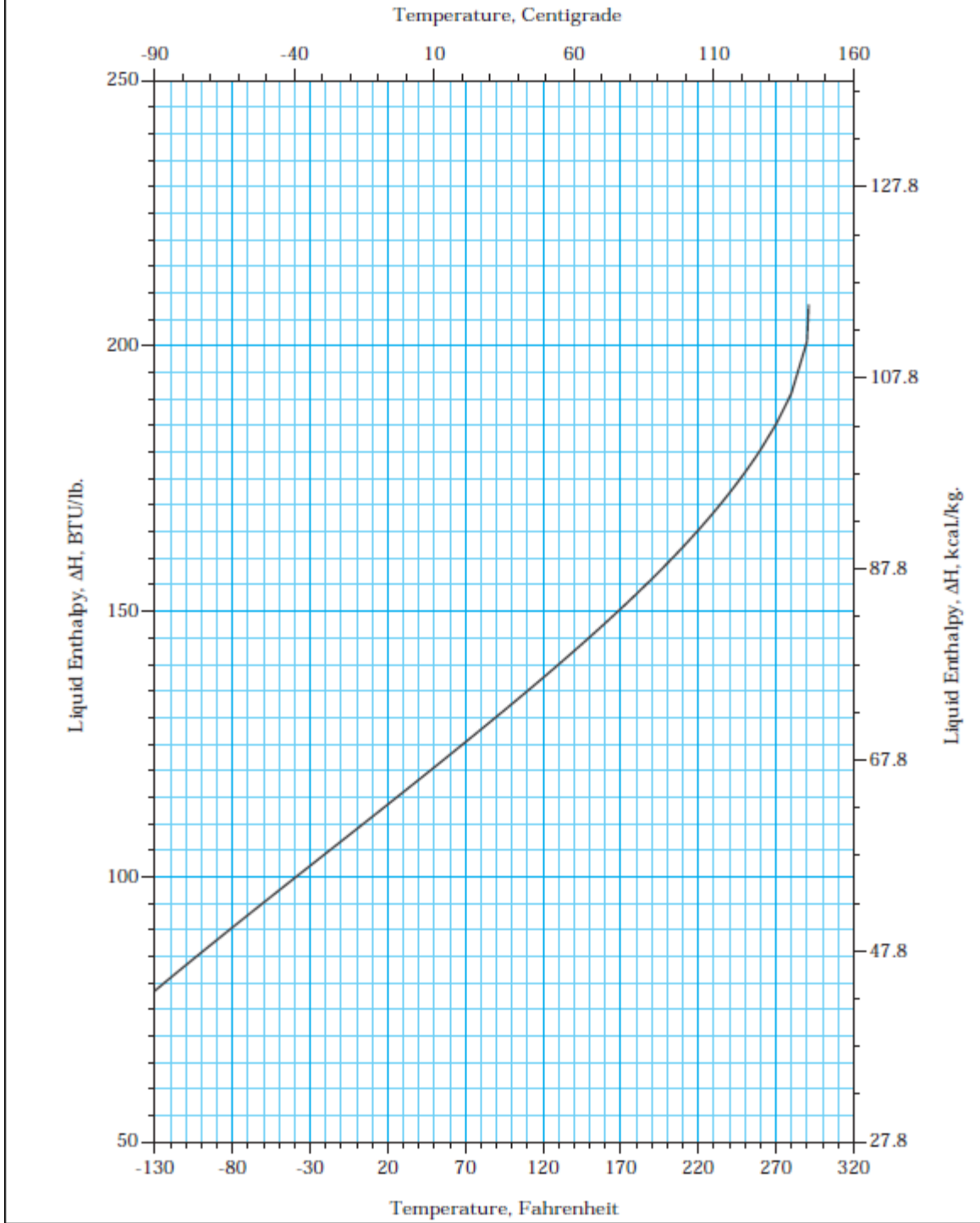

## Bibliography

- Kapoor, R.N.; Martin, J.J.  
"Thermodynamic Properties of Chlorine"  
Engineering Research Institute,  
University of Michigan, Ann Arbor,  
Michigan (1957).
- Kirkbride, F.W.  
in Mellow, J.W.: "Inorganic and  
Theoretical Chemistry," Vol. II,  
Suppl. I, Sect. XIII.  
John Wiley & Sons Inc., New York  
(1956).
- Laubusch, E.J.  
in "Chlorine, Its Manufacture, Prop-  
erties and Uses," Ch. 3 (Ed.:  
Sconce, J.S.)  
ACS Monograph Series No. 154  
Reinhold Publishing Corp., New  
York (1962).
- McBride, B.J.; Heimel, S.; Ehlers,  
J.G.; Gordon, S.  
"Thermodynamic Properties to  
6000°K for 210 Substances Invol-  
ving the First 18 Elements"  
NASA SP-3001. Lewis Research  
Center, Cleveland, Ohio (1963).
- McGlashan, M.L.  
"IUPAC Manual of Symbols and  
Terminology for Physicochemical  
Quantities and Units"  
Pure Appl. Chem 21, 1 (1970).
- Mussini, T.; Faita, G.  
in "Encyclopedia of Electrochem-  
istry of the Elements,"  
Vol. 1, Ch. 1 (Ed.: Bard, A.J.)  
Marcel Dekker, Inc., New York  
(1973).
- Setty, H.S.N.; Smith, J.D.; Yaws,  
C.L.  
Chem. Eng., 81 (12) 70 (1974).
- Stull, D.R.; Prophet, H.  
"JANAF Thermochemical Tables"  
2nd Ed.  
NSRDS – NBS37  
National Bureau of Standards,  
Washington, D.C., (1971).
- Svehla, R.A.  
"Estimated Viscosities and Thermal  
Conductivities of Gases at High  
Temperatures"  
NASA Technical Report R-132  
Lewis Research Center, Cleveland,  
Ohio (1962).
- Ziegler, L.  
Chem. Ing. Tech., 22, 229 (1950).

The Chlorine Institute ([www.chlorineinstitute.org](http://www.chlorineinstitute.org)) provides additional chlorine safety and handling information and training materials. The applicable Chlorine Institute pamphlets should be thoroughly reviewed prior to handling or using chlorine.

For additional information on chlorine and chlorine products contact OxyChem's Technical service group at 1-800-733-1165 , option 2

Visit the Chlorine Tree at [www. Chlorinertree.org](http://www.Chlorinertree.org) to see how chlorine and its by-products touch nearly every facet of our everyday lives.

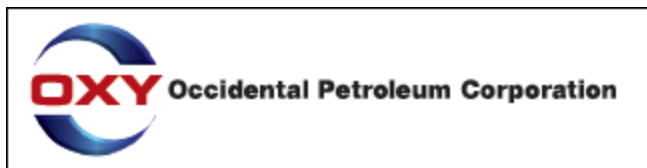

## **OXYCHEM**

5005 LBJ Freeway  
Suite 2200  
Dallas, TX 75380  
1-800-733-1165 option 2