

This is another older problem (2010 rules) that can be tweaked ...see suggestions below

- Change layout gas placards to 2019 rules order..... CH₄, CO and O₂
- Put gas placards against conditions (caved, unsafe roof, etc.) you want the gas to extend into
- Change air shaft to circle symbol on team maps
- Remove stick frames from BC
- Vents on this problem need to keep low O₂ from going over Briefing officer
- You can add to team instructions that the BO is underground and not let low O₂ flow over his/her location

PROBLEM 14 – 2010 RULES

JULY 12 – 16, 2010

THANK YOU FOR COMING TO OUR AID. TWO DAYS AGO WE HAD A SEVERE ELECTRICAL STORM. DURING THE STORM THE POWER KNOCKED ON THE SURFACE AND UNDERGROUND. WE IMMEDIATELY STARTED EVACUATING THE MINE.

THE SECTION FOREMAN ON 7 LEFT CALLED AND TOLD THE RESPONSIBLE PERSON THE CREW HAD COME UPON SMOKE WHILE TRAVELING DOWN THE SECTION TRACKWAY. THE FOREMAN TOLD THE RESPONSIBLE PERSON HE WAS NOW TRAVELING THE ESCAPEWAY TOWARD THE SURFACE WITH HIS CREW.

APPROXIMATELY ONE HOUR LATER THE 7 LEFT CREW ARRIVED ON THE SURFACE; HOWEVER, THE SECTION FOREMAN WAS NOT WITH THEM. THE CREW TOLD THE RESPONSIBLE PERSON THE FOREMAN HAD DISCOVERED TWO OF THE CREW MEMBERS WERE MISSING AND THE SECTION FOREMAN HAD GONE BACK TO SEARCH FOR THE MISSING MEN.

WE IMMEDIATELY REQUESTED MINE RESCUE TEAMS AND CONTACTED THE AGENCIES. ONCE MINE RESCUE TEAMS WERE HERE THEY TRAVELED INSIDE TO FIND OUR PEOPLE AND TO FIND OUT WHERE THE SMOKE HAD COME FROM THE 7 LEFT FOREMAN REPORTED.

A FIRE WAS DISCOVERED ON THE 7 LEFT SECTION, NUMBER 1 BELT. THE MINE RESCUE TEAMS WORKED TO GET THE FIRE OUT WHILE TRYING TO LOCATE THE THREE MISSING PEOPLE. THE FIRE WAS BROUGHT UNDER CONTROL AND EXTINGUISHED TWO HOURS AGO; HOWEVER, AFTER HAVING PEOPLE WALK ALL THE ENTRIES FROM THIS FRESH AIR BASE TO THE SURFACE WE HAVE NOT FOUND OUR PEOPLE.

IN AN EFFORT TO KEEP THE SMOKE OFF OUR MISSING PEOPLE IN THE EVENT THEY WERE INBY, A MINE RESCUE TEAM TRAVELED INBY THE FIRE AND KNOCKED THE STOPPINGS HERE WHERE THIS FRESH AIR BASE HAS BEEN ESTABLISHED WHILE WE WERE FIGHTING THE BELT FIRE.

AFTER KNOCKING THE STOPPINGS THE MINE RESCUE TEAM BUILT TEMPORARY STOPPINGS ACROSS ALL THREE ENTRIES. IT WAS HOPED THAT BUILDING THE TEMPORARY STOPPINGS WOULD PREVENT SMOKE FROM TRAVELING INBY THIS AREA.

THIS MINE HAS A BLOWING FAN WHICH PUSHES AIR UP THE NUMBER 1 ENTRY. THIS MINE ALSO HAS AN EXHAUSTING FAN WHICH PULLS AIR DOWN THE NUMBER 3 ENTRY. BOTH FANS ARE CURRENTLY RUNNING AND CANNOT BE STOPPED OR REVERSED.

THIS IS ALL THE INFORMATION I HAVE AT THIS TIME!

PROBLEM

LOCATE THE MISSING PEOPLE

BRING ANY SURVIVORS TO THE SURFACE

PROBLEM MAP

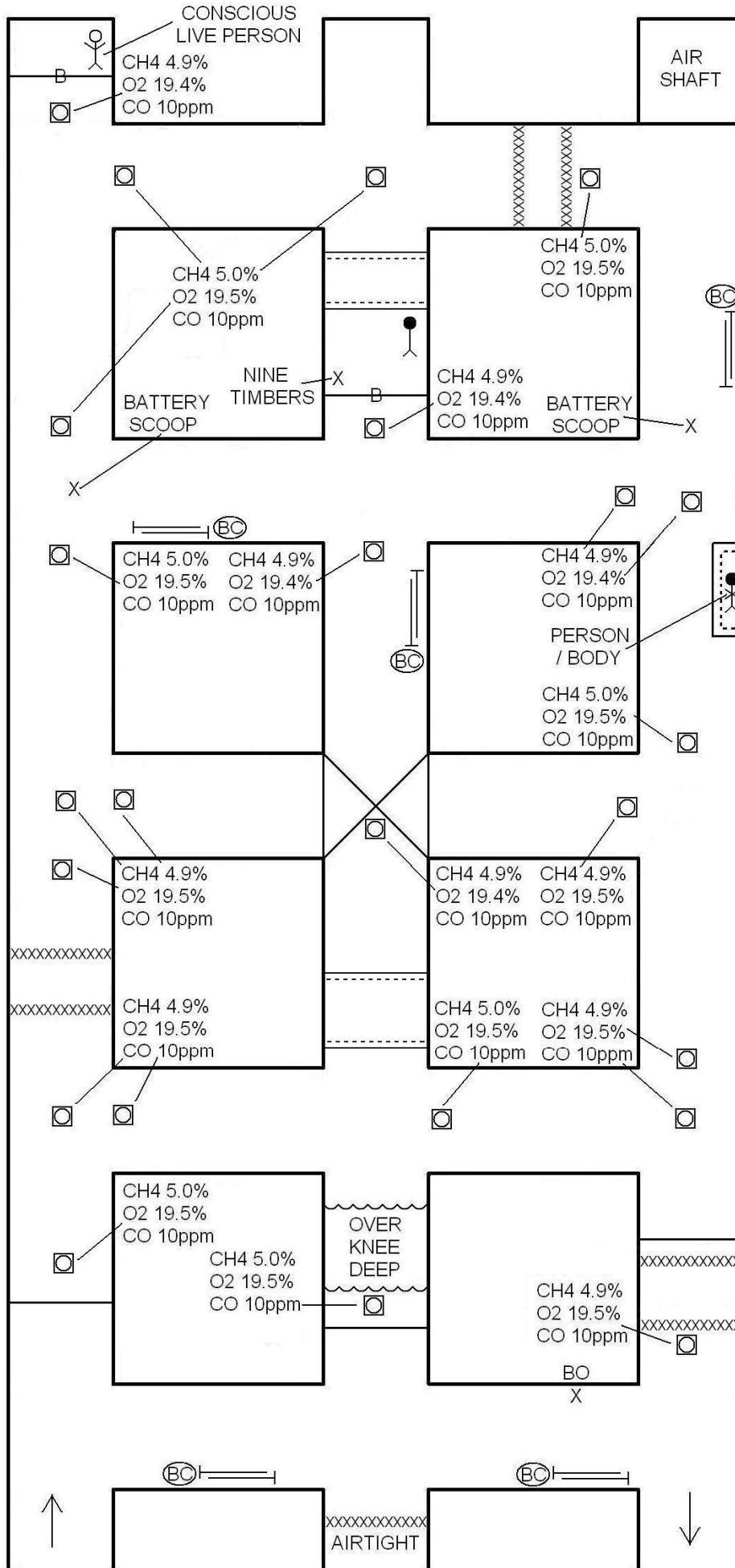

VENTILATION 1

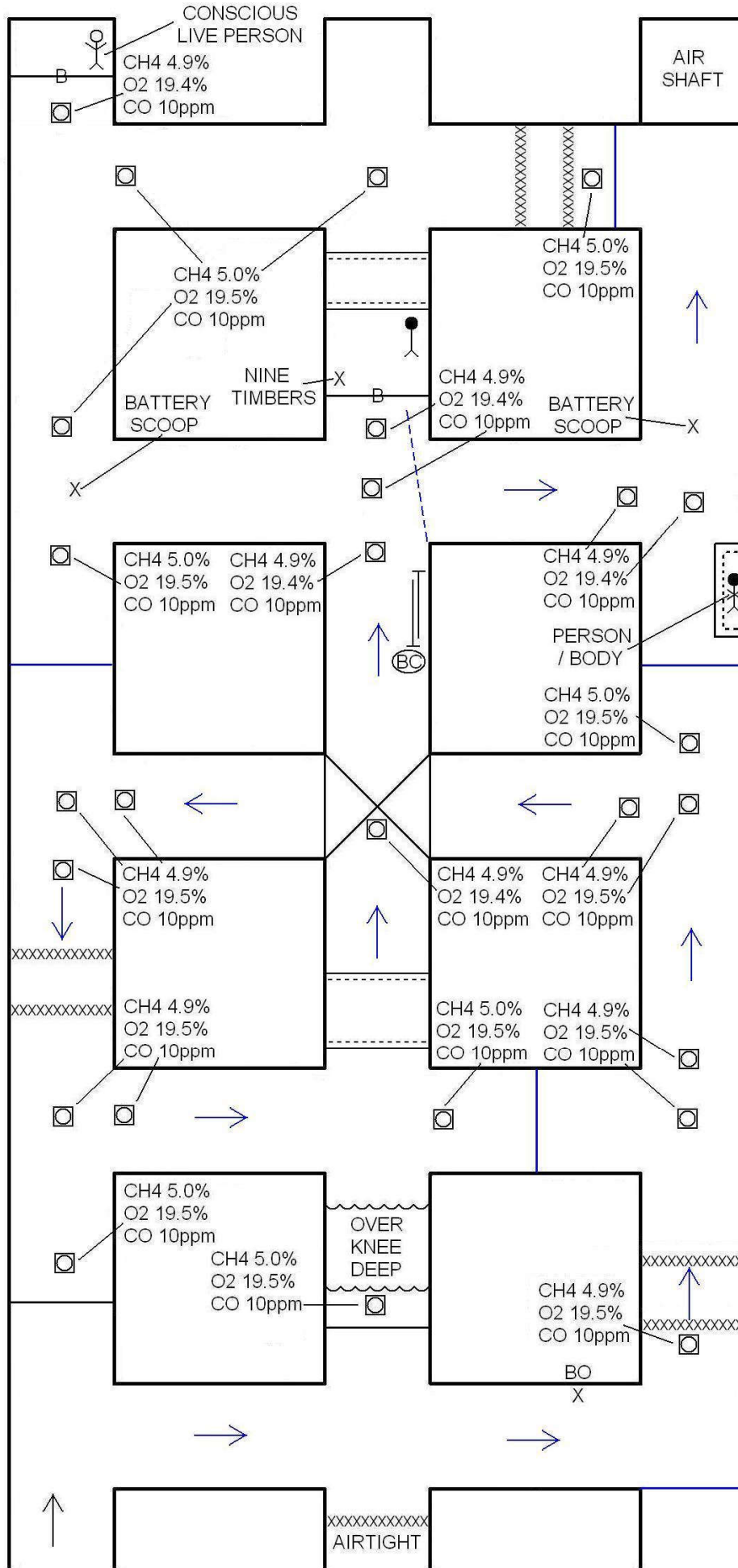

VENTILATION 2

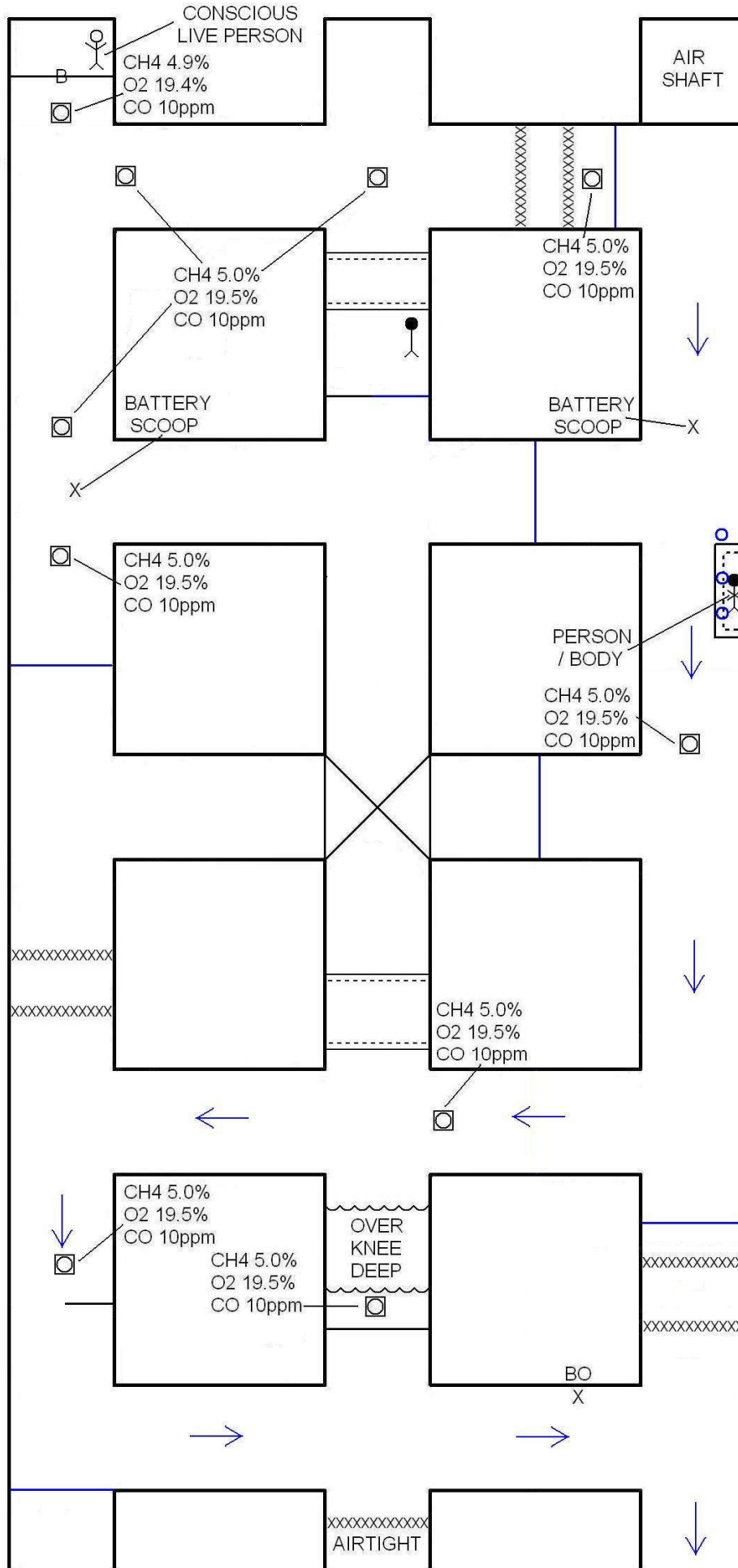

VENTILATION 3

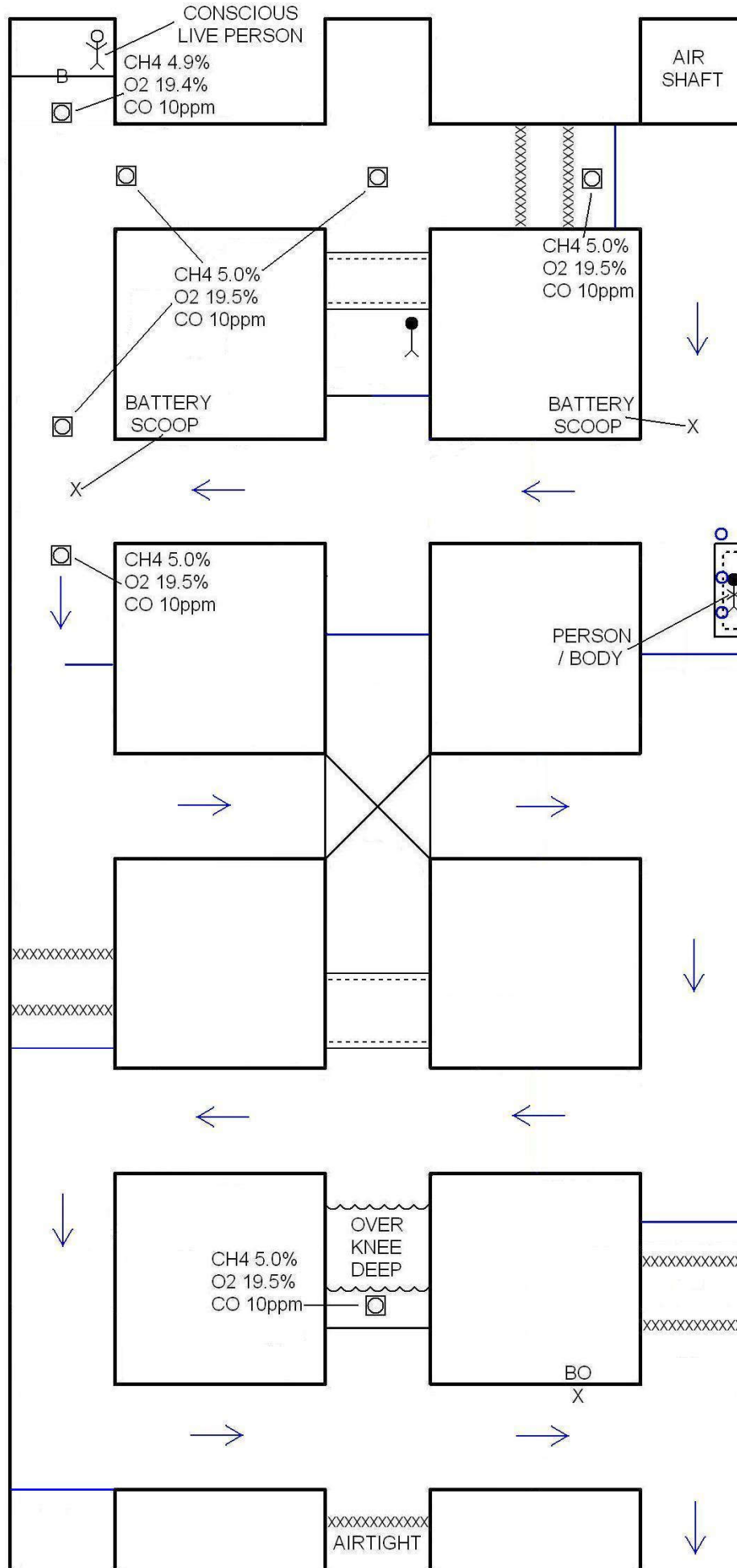

VENTILATION 4

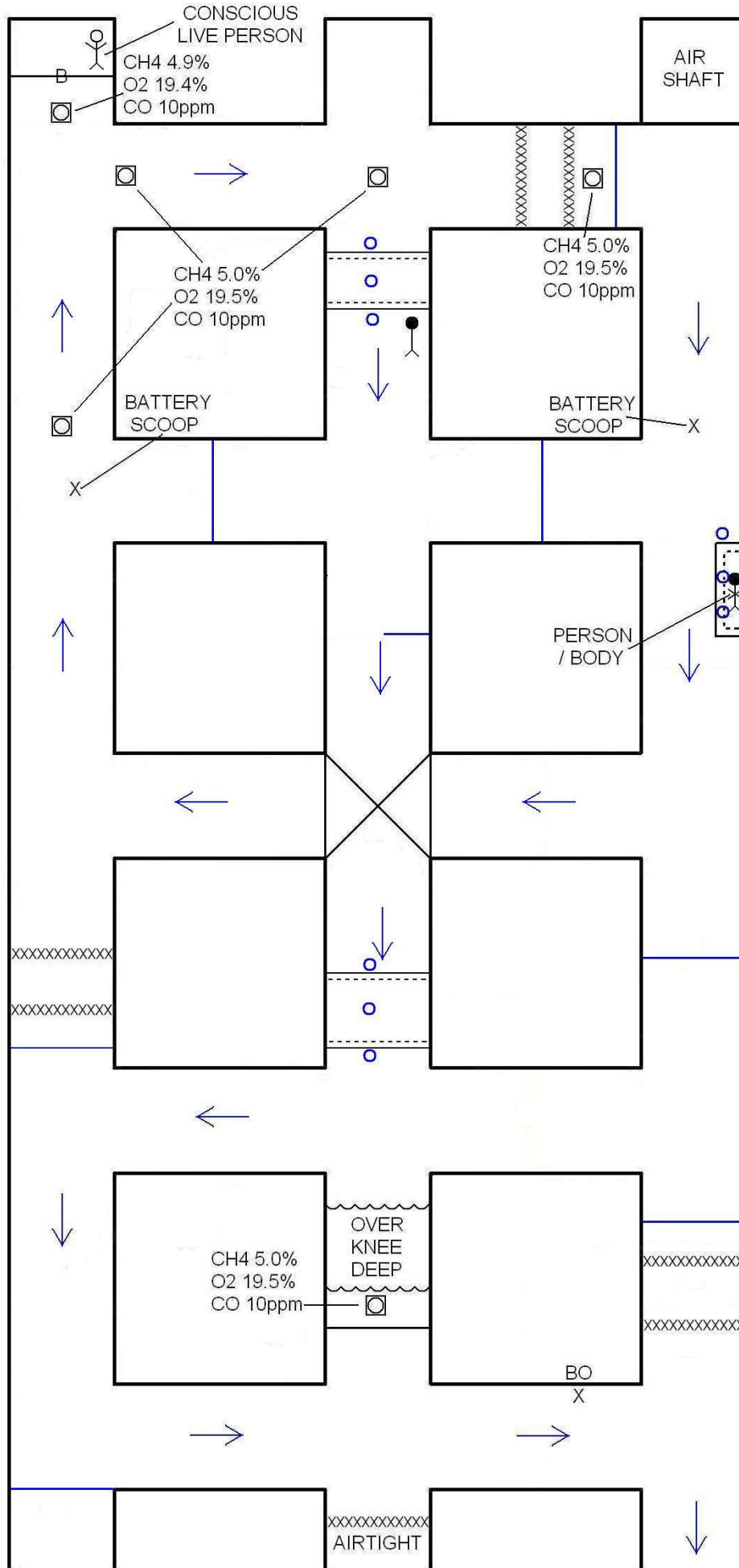

VENTILATION 5

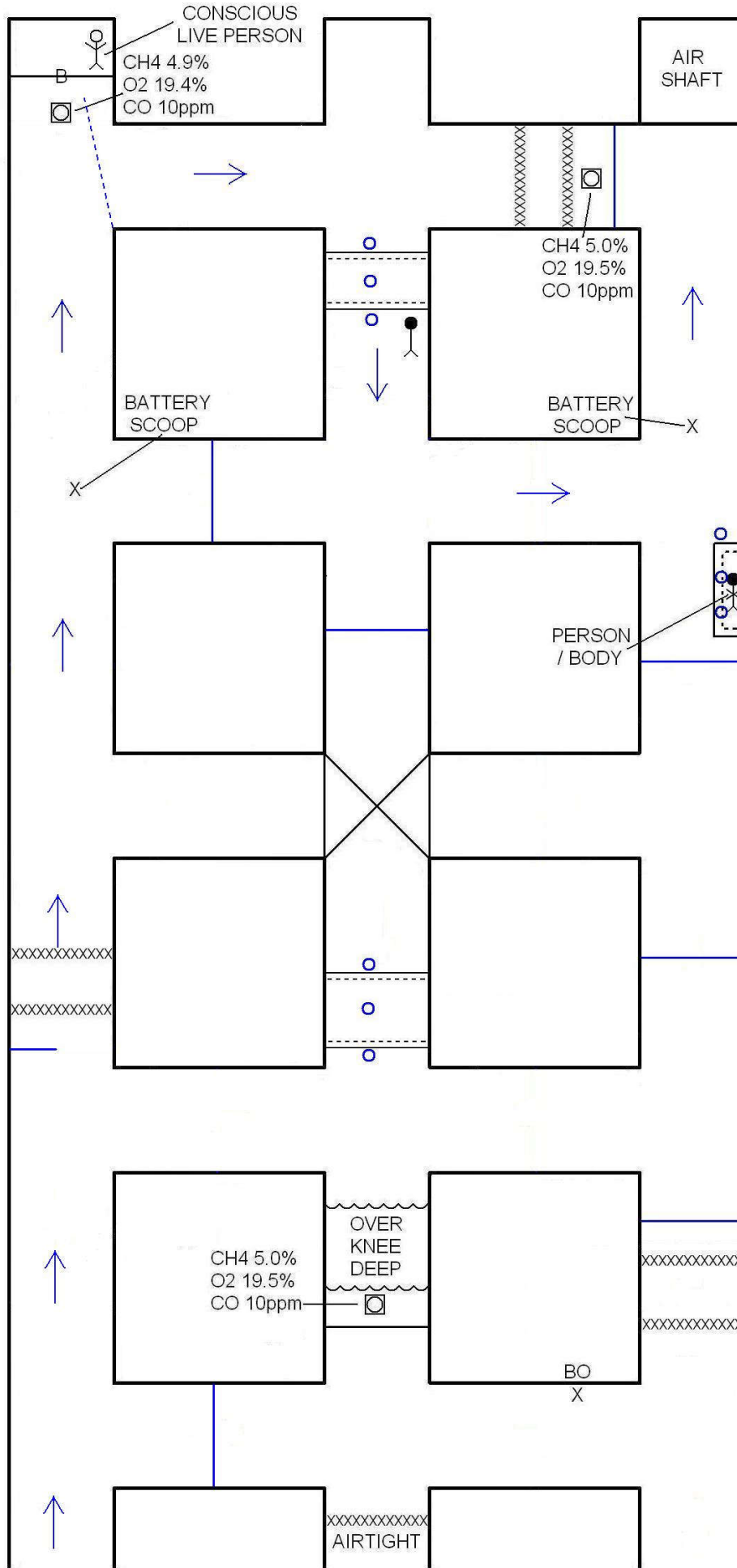

TEAM STOPS

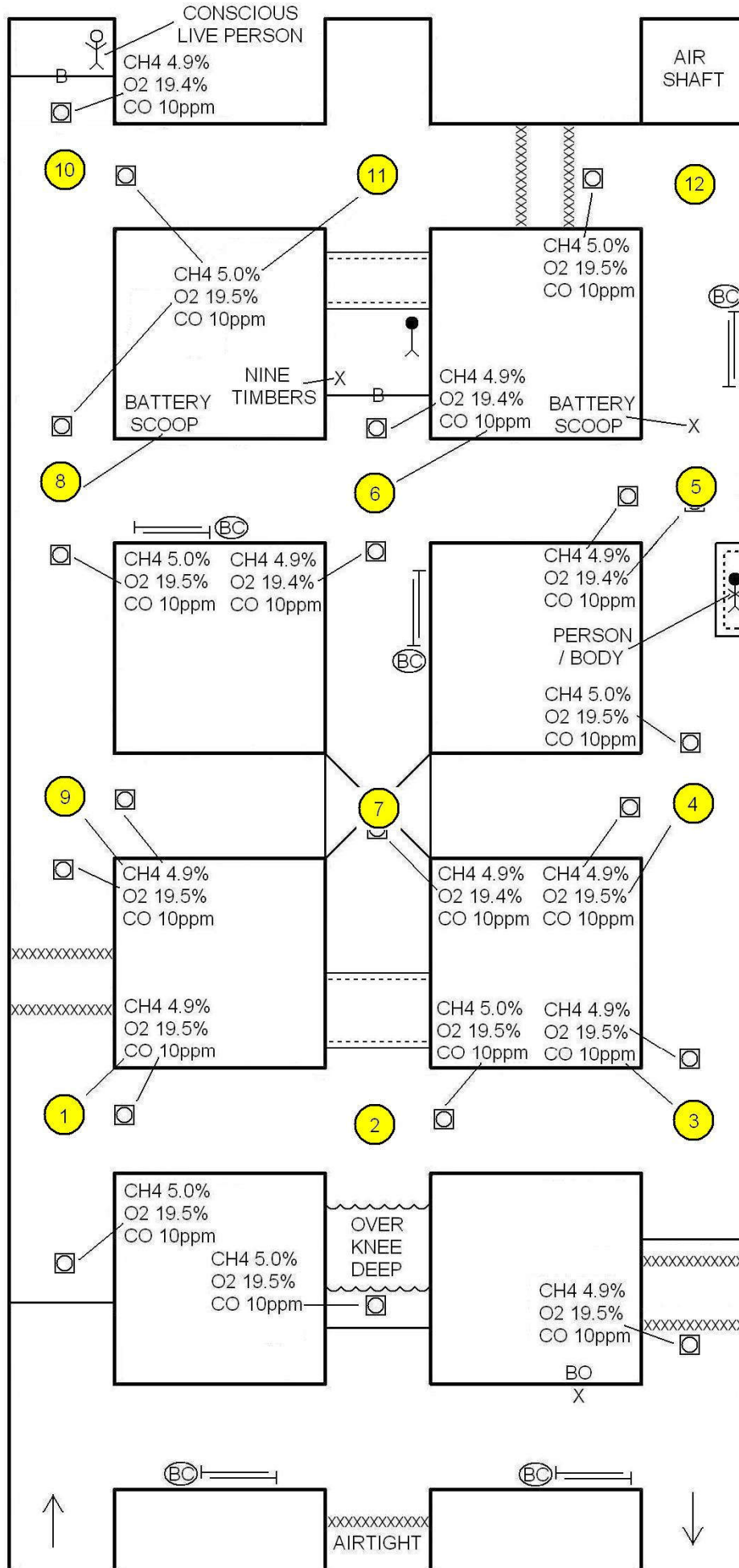

LAYOUT MAP

