

2020 INDIANA MINE RESCUE STATEMENT

I am _____, Superintendent of the Federal #14 Mine. You are located on the surface of the mine. Last night a four (4) man crew entered the mine and proceeded to the #1 Unit to perform maintenance and set up to run coal. At 6:35 a.m. this morning a miner called to surface from the unit and said they were mining coal in the #2 entry. No contact has been established with the miners since the call. At 6:50 a.m., two (2) miners made it out of the mine. The miners who came out said they could not find the other miners and had no contact with them.

The #1 Unit is developing the mine from a box cut but has already experienced bad roof and rib conditions, water problems, and high concentrations of methane gas. This area has been heavily mined in the past and we hope we haven't hit any unmapped old works. Our maps for this mine are up to date at this time.

The #1 Unit has been ventilated by a blowing fan that can be turned on or off if needed. The fan is currently off, but air enters the mine through the Portal in the #3 entry. All power going into the mine has been de-energized and locked out. Air pumps can be used if available. The entries are numbered left to right (#1, #2, and #3).

All proper authorities have been notified, a command center has been established on the surface, back-up mine rescue teams are on mine property but cannot be used to perform work underground.

This is all the information we have available at this time.

**2020 INDIANA
MINE RESCUE CONTEST**

WRITTEN INSTRUCTIONS

**EXPLORE THE MINE IN ITS ENTIRETY WHERE
SAFE TO DO SO. VENTILATE THE MINE AND
LEAVE THE MINE FOR BAREFACED
EXPLORATION.**

**THE FAN YOU ARE WORKING WITH CAN BE
REVERSED BUT NOT STALLED.**

**ACCOUNT FOR ALL MISSING PERSONS AND
BRING ALL SURVIVORS OUTSIDE TO FRESH AIR.**

**THE TEAM MAY NOT CARRY MORE THAN TWO
(2) BRATTICE CURTAINS AT ANY ONE TIME
WHILE ADVANCING OR RETREATING.**

BRIEFING OFFICER MAP

Team Working Order # _____

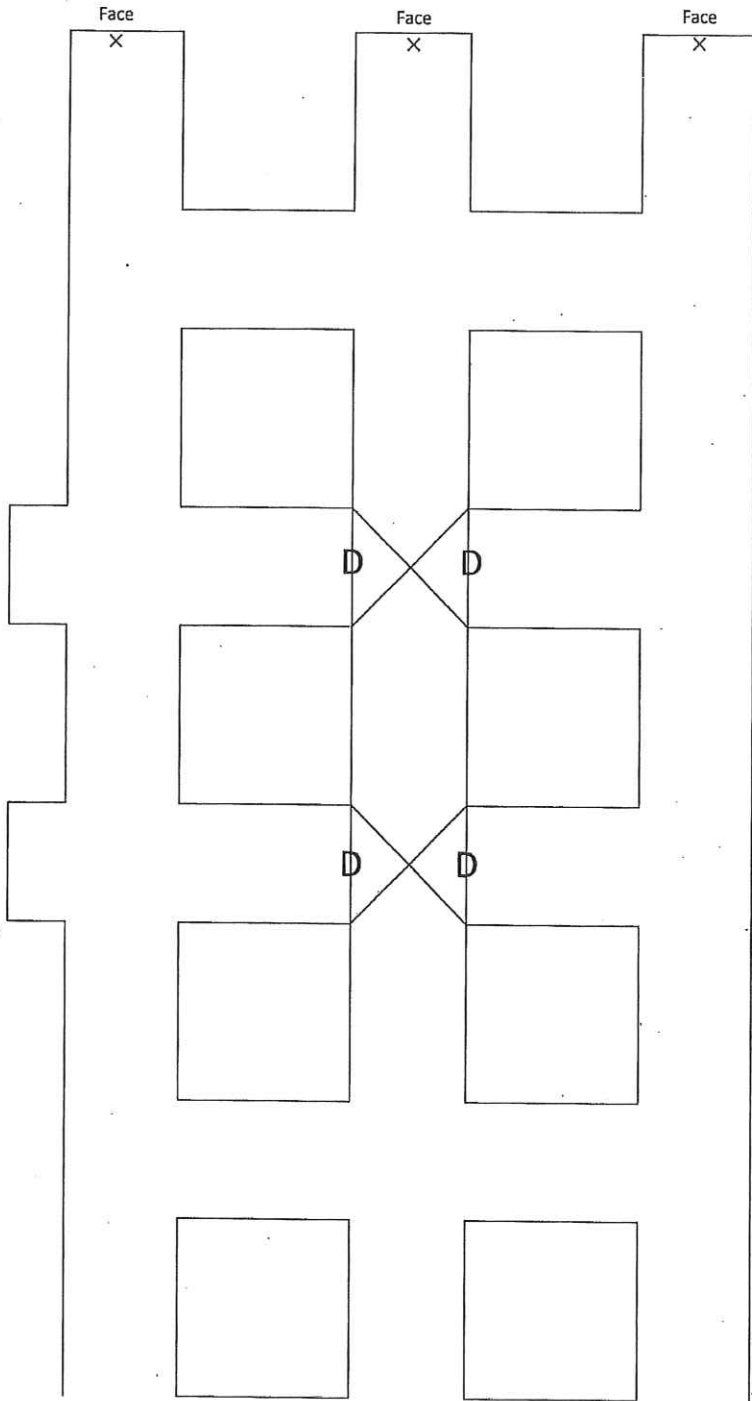

XC #4

XC #3

XC #2

XC #1

2020 INDIANA MINE RESCUE CONTEST

Ⓢ

CHECK BOX TO
DESIGNATE THIS
MAP TO BE USED
FOR SCORING
PURPOSES



FIELD MAP

Team Working Order # _____

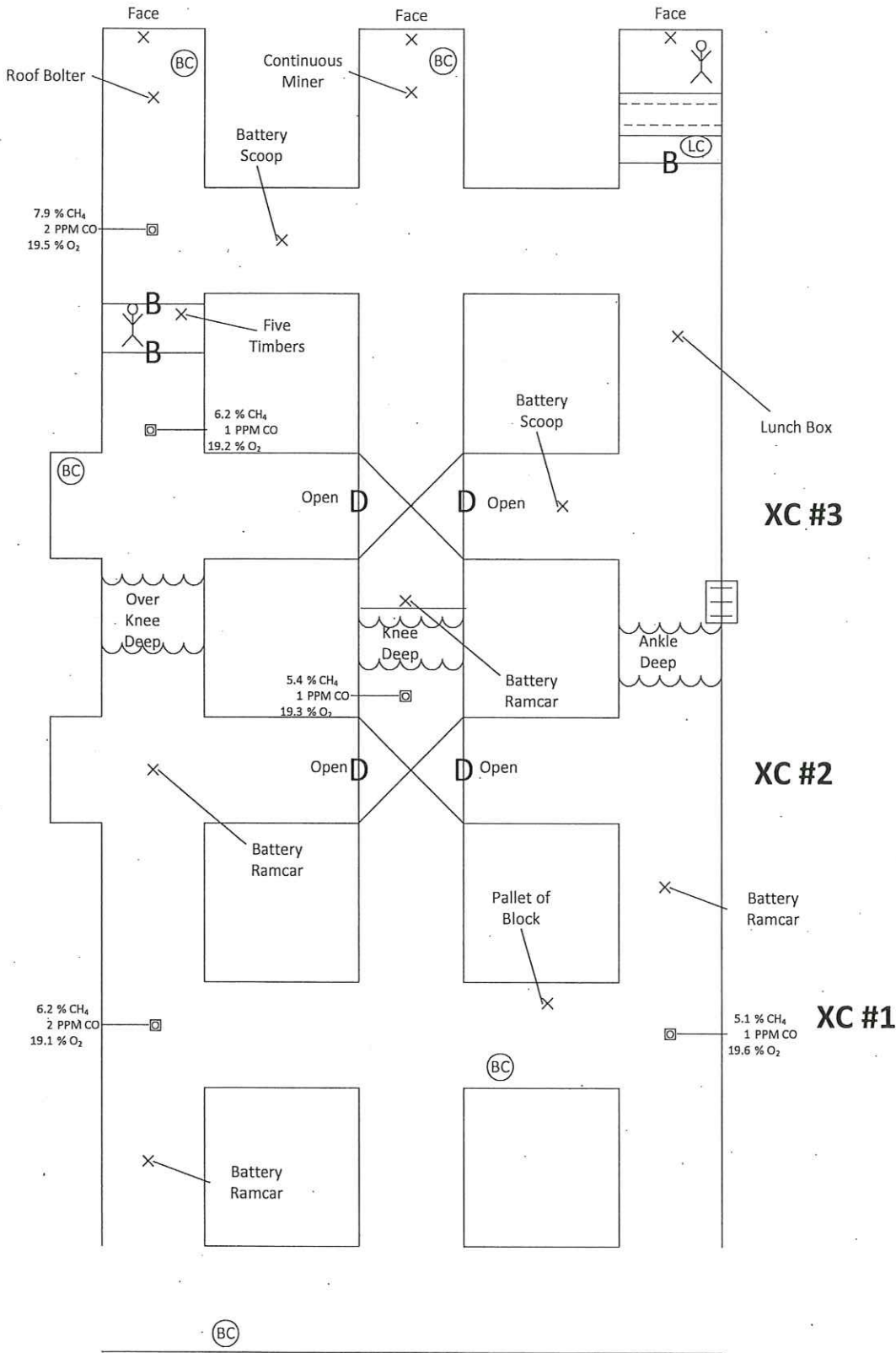

2020 INDIANA MINE RESCUE CONTEST

CHECK BOX TO
DESIGNATE THIS
MAP TO BE USED
FOR SCORING
PURPOSES



First Vent

Team Working Order # _____

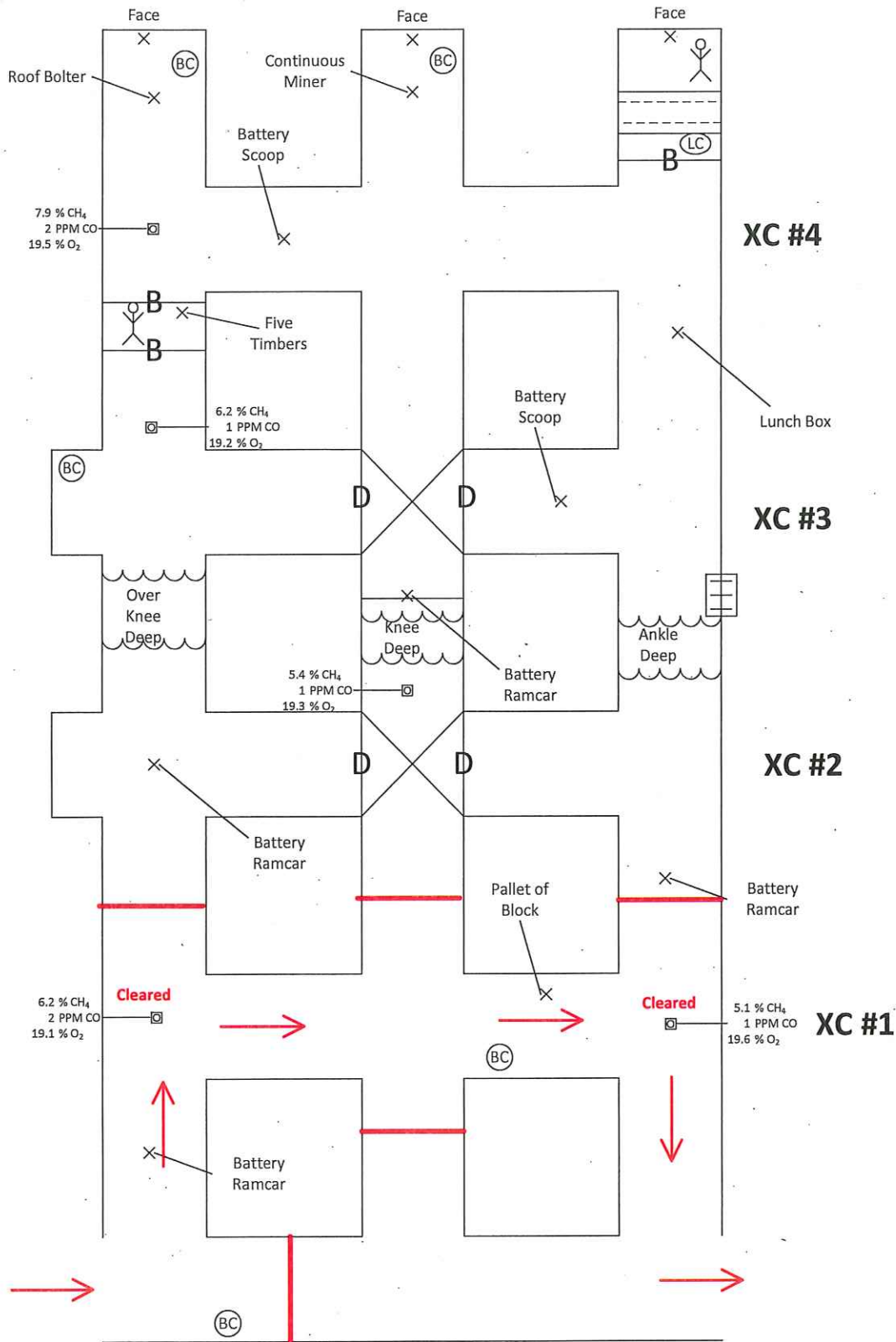

2020 INDIANA MINE RESCUE CONTEST

CHECK BOX TO DESIGNATE THIS MAP TO BE USED FOR SCORING PURPOSES

Second Vent

Team Working Order #. _____

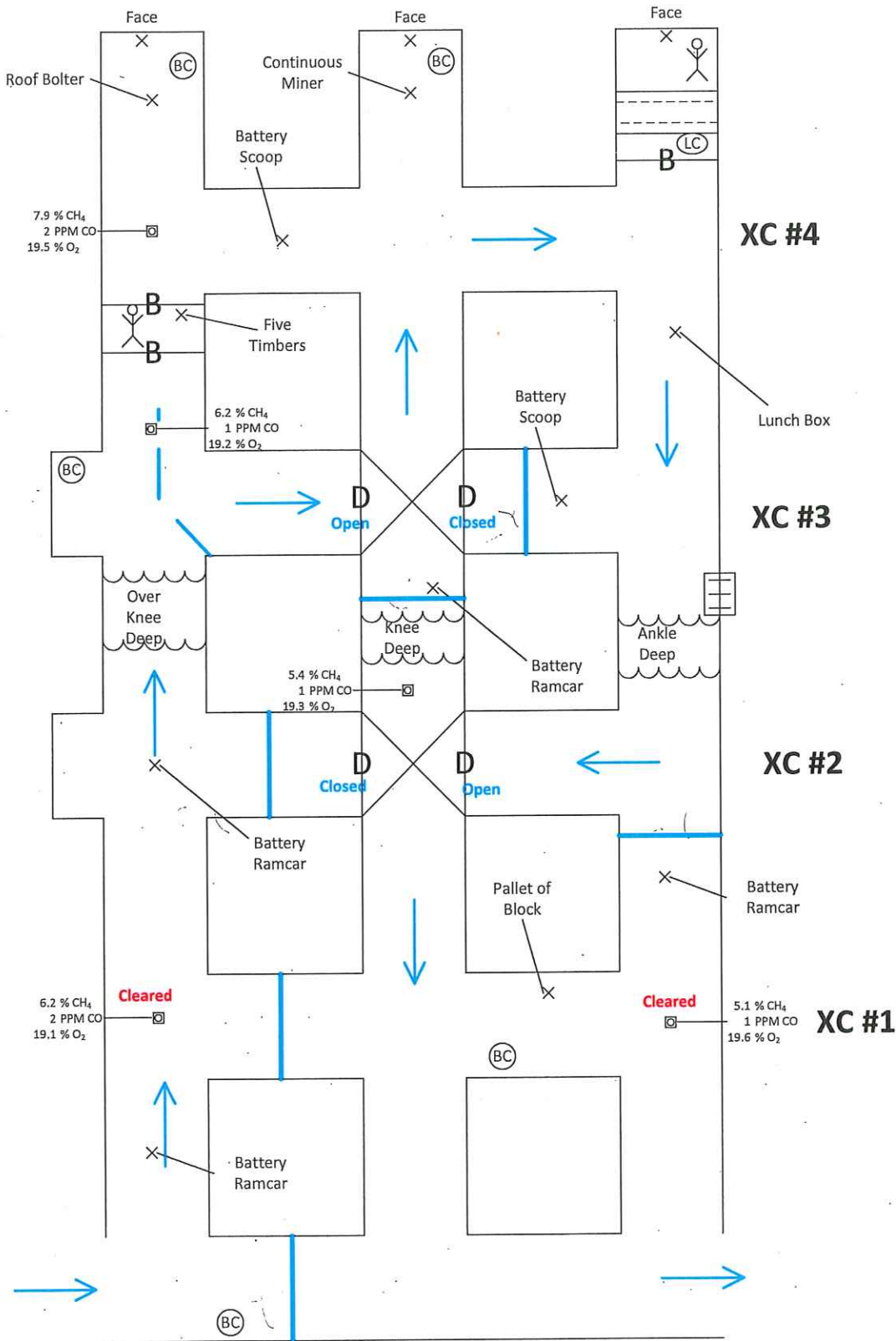

2020 INDIANA MINE RESCUE CONTEST

CHECK BOX TO DESIGNATE THIS MAP TO BE USED FOR SCORING PURPOSES



Third Vent

Team Working Order # _____

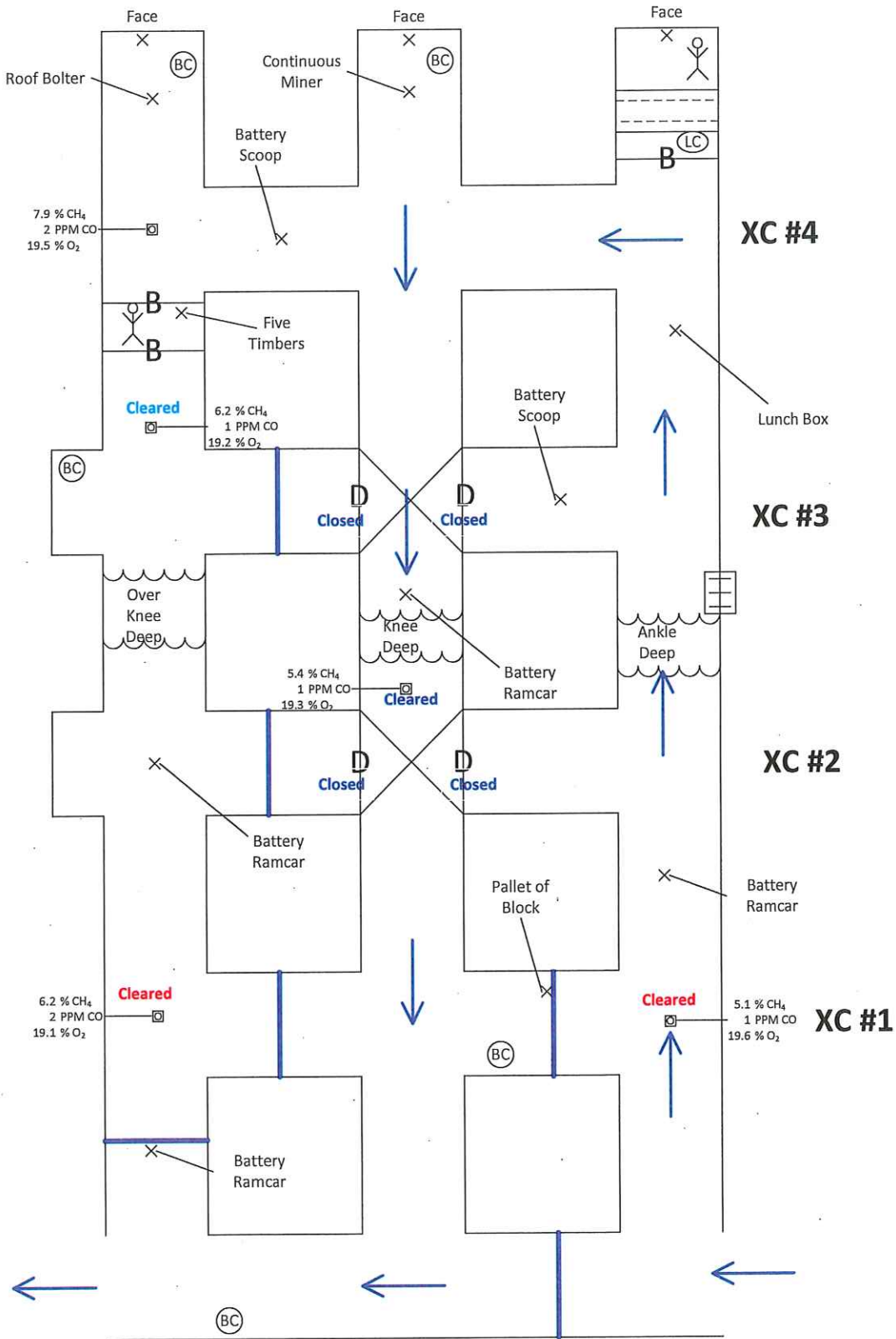

2020 INDIANA MINE RESCUE CONTEST

CHECK BOX TO
DESIGNATE THIS
MAP TO BE USED
FOR SCORING
PURPOSES

FINAL VENT MAP

Team Working Order # _____

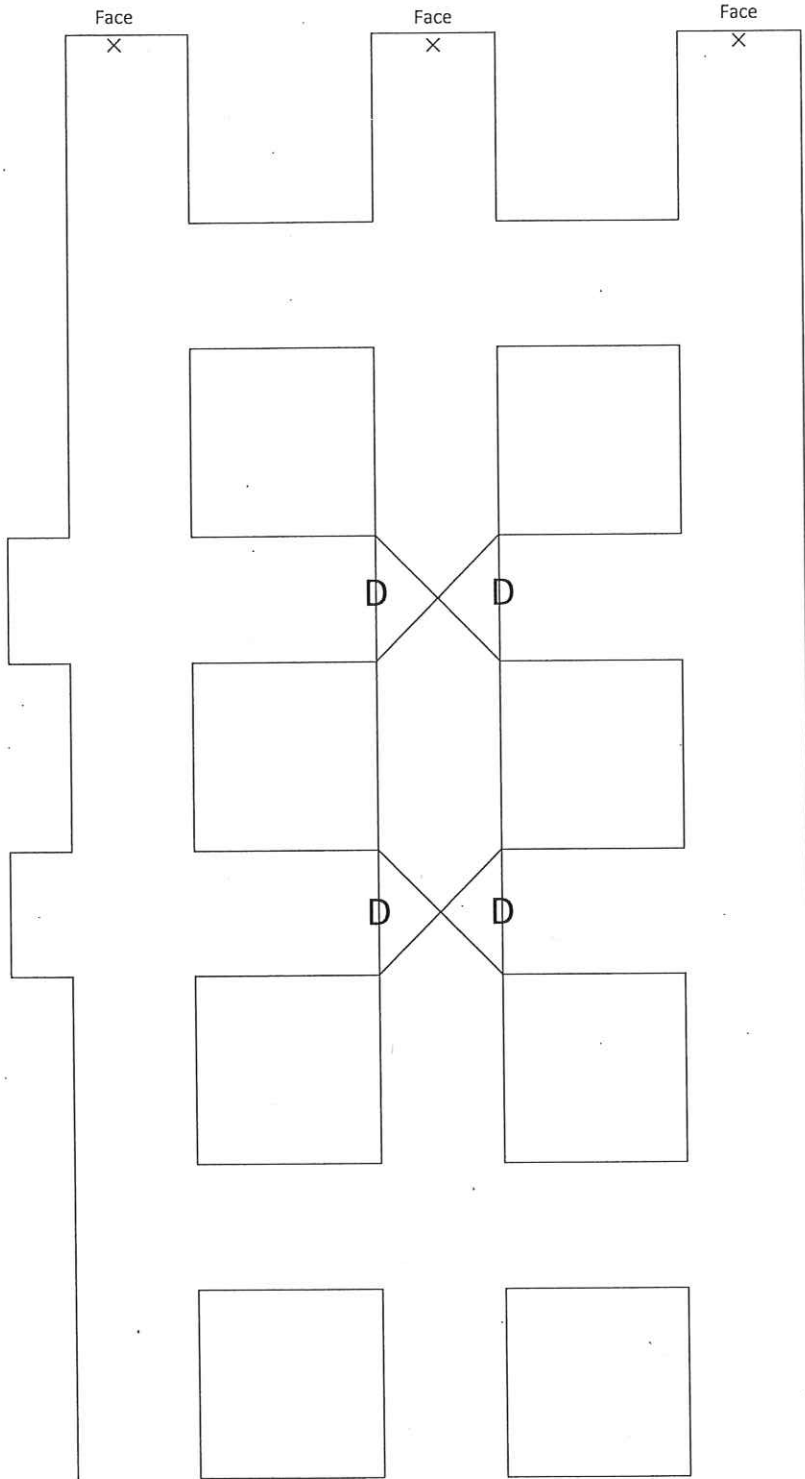

XC #4

XC #3

XC #2

XC #1

2020 INDIANA MINE RESCUE CONTEST

ⓑ

TEAM REPRESENTATIVE- _____

FIELD JUDGE- _____

CHECK BOX TO
DESIGNATE THIS
MAP TO BE USED
FOR SCORING
PURPOSES



Barricade in Entry #1

HELP! HELP!

I'M GETTING LIGHT

HEADED!

Barricade in Entry #3

HELP! THE TOP IS
WORKING! PLEASE
HURRY!