



2015  
KMI  
DAY 2

MH

**KMI MINE RESCUE CONTEST  
SUPERINTENDENT STATEMENT DAY 2  
AUGUST 20, 2015**

Thank you for coming to help us. You are located at the fresh air base of the KMI #2 mine. This is a very large mine with multiple working sections and interconnected fans and air courses.

This morning 75 miners entered the mine. Around 9:00 am this morning the incident occurred. There was a loud rush of air out the portals and the CO system alarmed. The Responsible Person tried to contact the miners underground but was not able to contact anyone. We reported this to MSHA and contacted mine rescue teams. At 10:30 am forty nine miners were able to escape. The other 26 miners are unaccounted for. There are multiple mine rescue teams working different areas of the mine at the same time you will be working.

A mine rescue team was able to explore to the area immediately inby the area you will be exploring. They were stopped by unsafe roof in the number 1 entry and caved areas in the number 2 and 3 entries. The team was able to setup a safe return inby the unsafe roof that you can use to ventilate through. The fan ventilating this area is exhausting and will pull air through the area you will be exploring if you do not maintain an airlock. The area is currently air-locked inby the fresh air base.

The air is currently going across the fresh air base and the return has been established so you can send smoke, and any gases out and they will not travel over any ignition source or unexplored area. The fan is currently blowing.

The mine has a history of bad roof, water and methane. The mine maps are up to date. We have a competent life line person to give and take life line signals if necessary.

Please find the 4 missing miners that were in this area of the mine that you will be exploring. Thank you and good luck.

## KMI DAY 2 PROBLEM

THE FAN INBY CANNOT BE TURNED OFF, STALLED, OR REVERSED DUE TO CAUSING DAMAGE TO THE FAN.

THE FAN VENTILATING THE FRESH AIR BASE CAN BE TURNED OFF AND REVERSED BUT CAN NOT BE STALLED DUE TO DAMAGE TO THE FAN.

THE RETURN AND INTAKE OUTBY THE FAB HAS BEEN EXPLORED AND IS SAFE TO VENTILATE THROUGH.

ACCOUNT FOR ALL 4 MISSING MINERS THAT ARE IN THE AREA YOU WILL BE EXPLORING AND BRING SURVIVORS TO THE FAB

EXPLORE ALL AREAS OF THE MINE THAT CAN BE DONE SAFELY. YOU MUST EXPLORE AND MAP THE ENTIRE ACCESSIBLE AREAS THAT ARE ON THE TEAM MAP PROVIDED.

EXPLORATION MUST BEGIN IN THE  
NUMBER ONE ENTRY DUE TO A BELIEF  
THAT SOME OF THE MINERS MAY BE  
LOCATED THERE.

WHILE THE TEAM IS MOVING YOU MAY  
ONLY TRANSPORT FOUR TIMBERS WITH  
YOU.

PATIENT STATEMENT  
DAY 2

HELP!! GET US OUT OF HERE,  
THERE ARE 2 OF US STILL ALIVE  
IN HERE.

# Problem Map

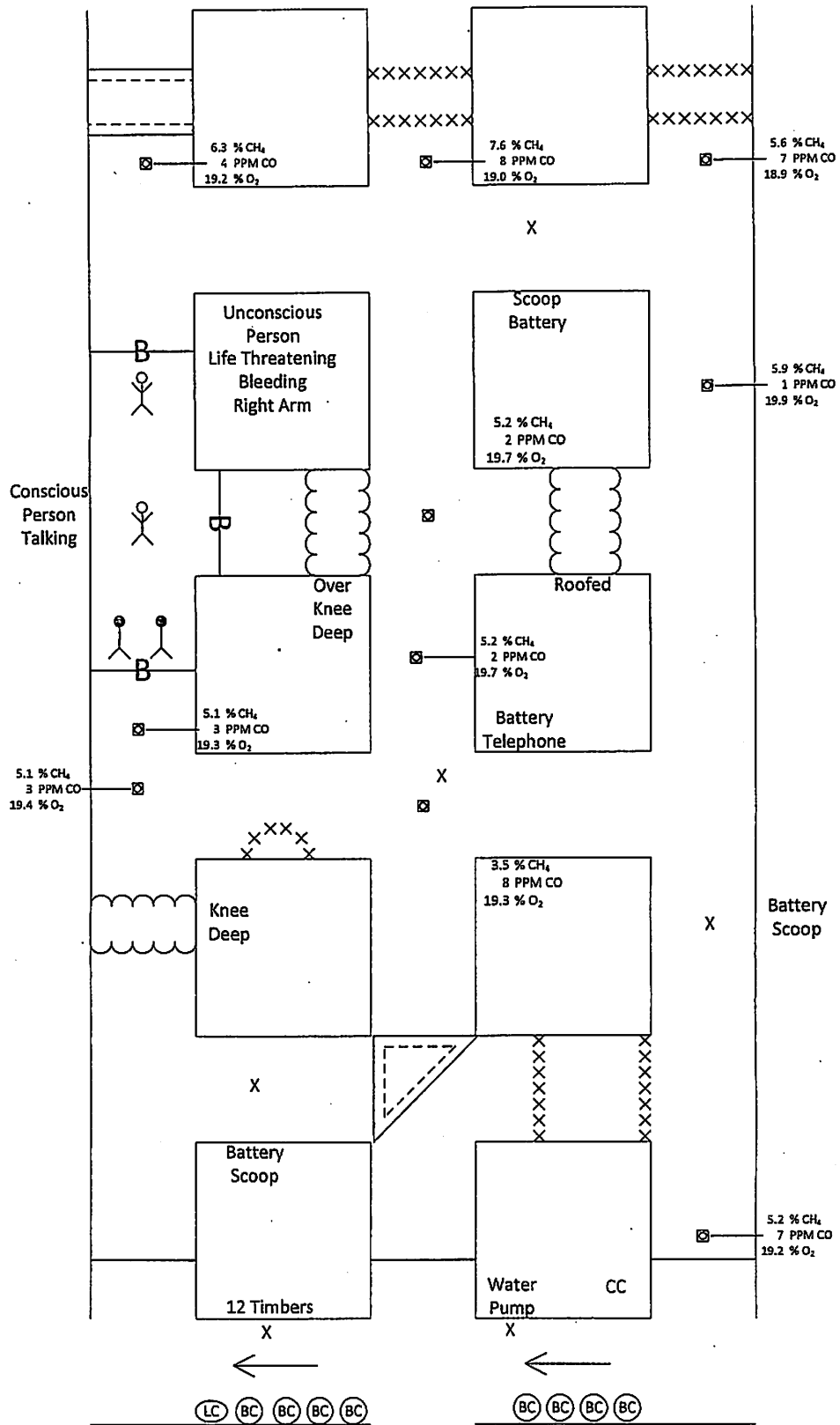

# Ventilation 1

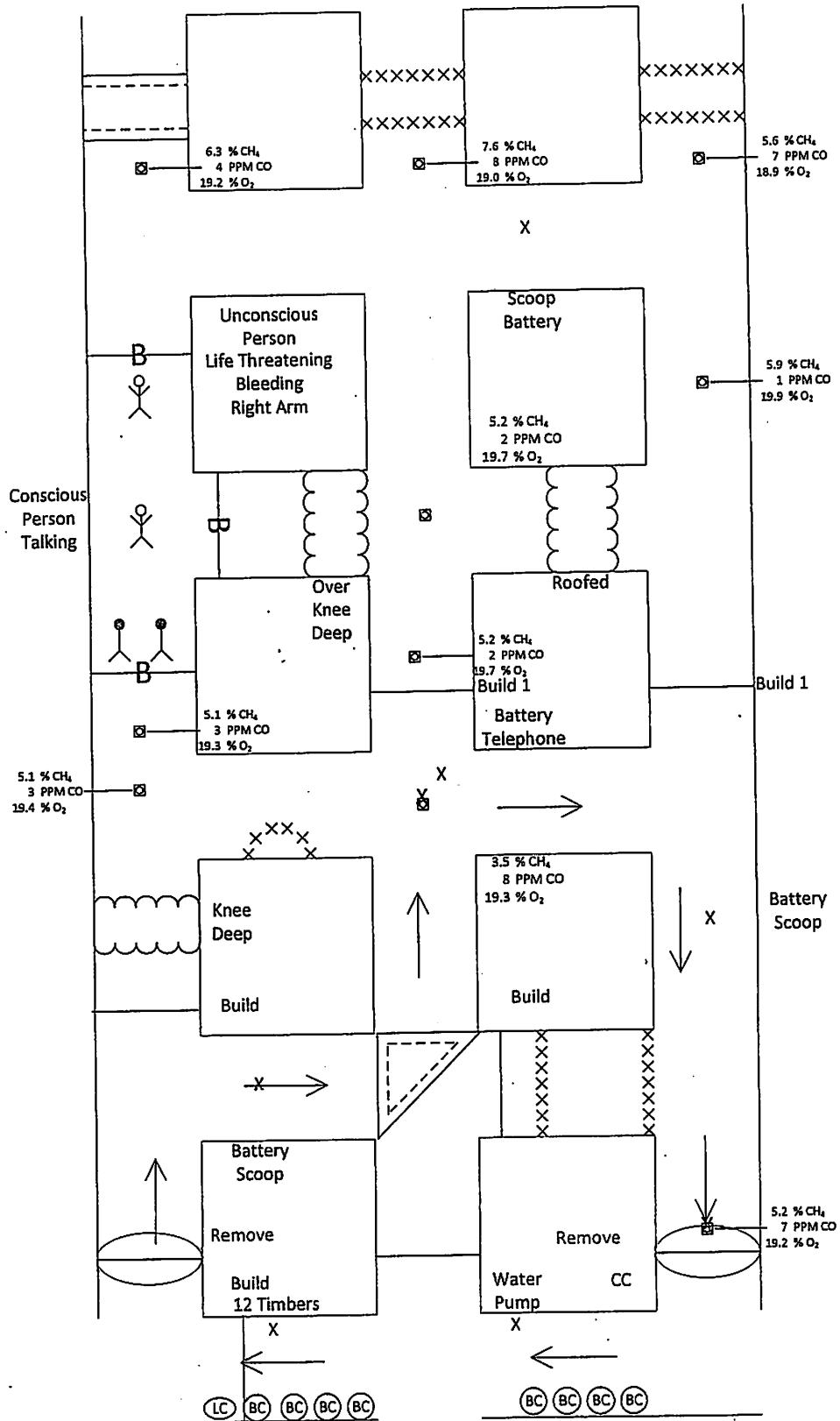



# Ventilation 2

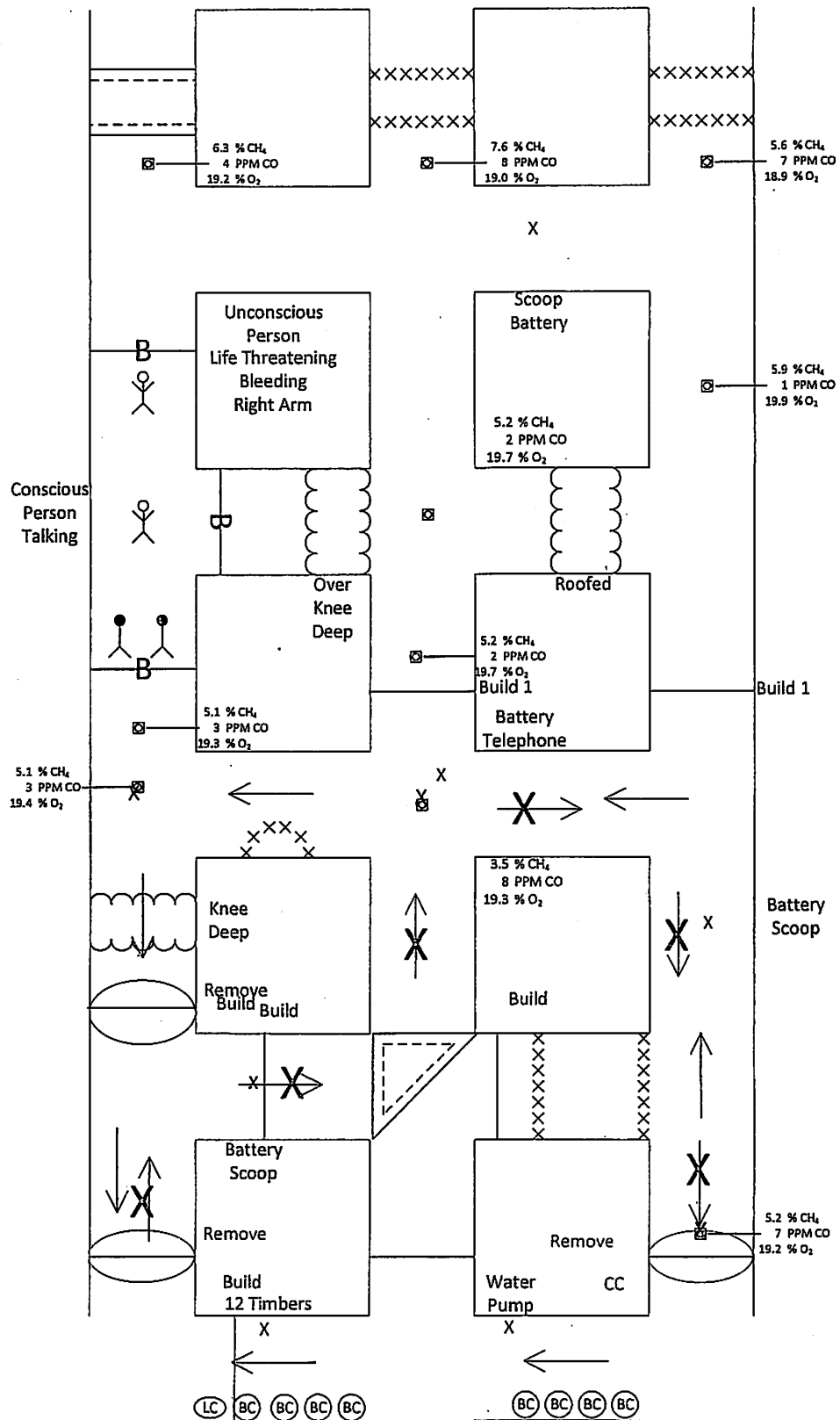

# Ventilation 3

