



2015  
HARLAN SAFETY DAYS CONTEST  
DAY 1

MH

**HARLAN SAFETY DAYS MINE RESCUE CONTEST  
SUPERINTENDENT STATEMENT DAY 1  
JULY 15, 2015**

Thank you for coming to help us. You are located at the fresh air base of the Harco #1 mine. This is a very large mine with multiple working sections and interconnected fans and air courses.

This morning 89 miners entered the mine. Around 9:00 am this morning the incident occurred. There was a loud rush of air out the portals and the CO system alarmed. The Responsible Person tried to contact the miners underground but was not able to contact anyone. We reported this to MSHA and contacted mine rescue teams. At 10:30 am sixty miners were able to escape. The other 29 miners are unaccounted for. There are multiple mine rescue teams working different areas of the mine at the same time you will be working.

A mine rescue team was able to explore to the area immediately inby the area you will be exploring. They were stopped by unsafe roof in the number 1, 2, and 3 entries. The team was able to setup a safe return inby the unsafe roof that you can use to ventilate through any of the entries. The fan ventilating this area is exhausting and will pull air through the area you will be exploring if you do not maintain an airlock.

The air is currently going across the fresh air base and the return has been established so you can send smoke, and any gases out and they will not travel over any ignition source or unexplored area. The fan is currently blowing.

The mine has a history of bad roof, water and methane. The mine maps are up to date. We have a competent life line person to give and take life line signals if necessary.

Please find the 6 missing miners that were in this area of the mine that you will be exploring. Thank you and good luck.

## **DAY 1 PROBLEM**

**THE FAN INBY CANNOT BE TURNED OFF, STALLED, OR REVERSED DUE TO CAUSING DAMAGE TO THE FAN.**

**THE FAN VENTILATING THE FRESH AIR BASE CAN BE STOPPED OR REVERSED BUT CAN NOT BE STALLED DUE TO CAUSING DAMAGE TO THE FAN.**

**THE RETURN AND INTAKE OUTBY THE FAB HAS BEEN EXPLORED AND IS SAFE TO VENTILATE THROUGH.**

**ACCOUNT FOR ALL 6 MISSING MINERS THAT ARE IN THE AREA YOU ARE EXPLORING AND BRING SURVIVORS TO THE FAB**

**EXPLORE ALL AREAS OF THE MINE THAT CAN BE DONE SAFELY**

# **PATIENT STATEMENT**

**HELP!! GET ME OUT OF HERE.**

Problem Map

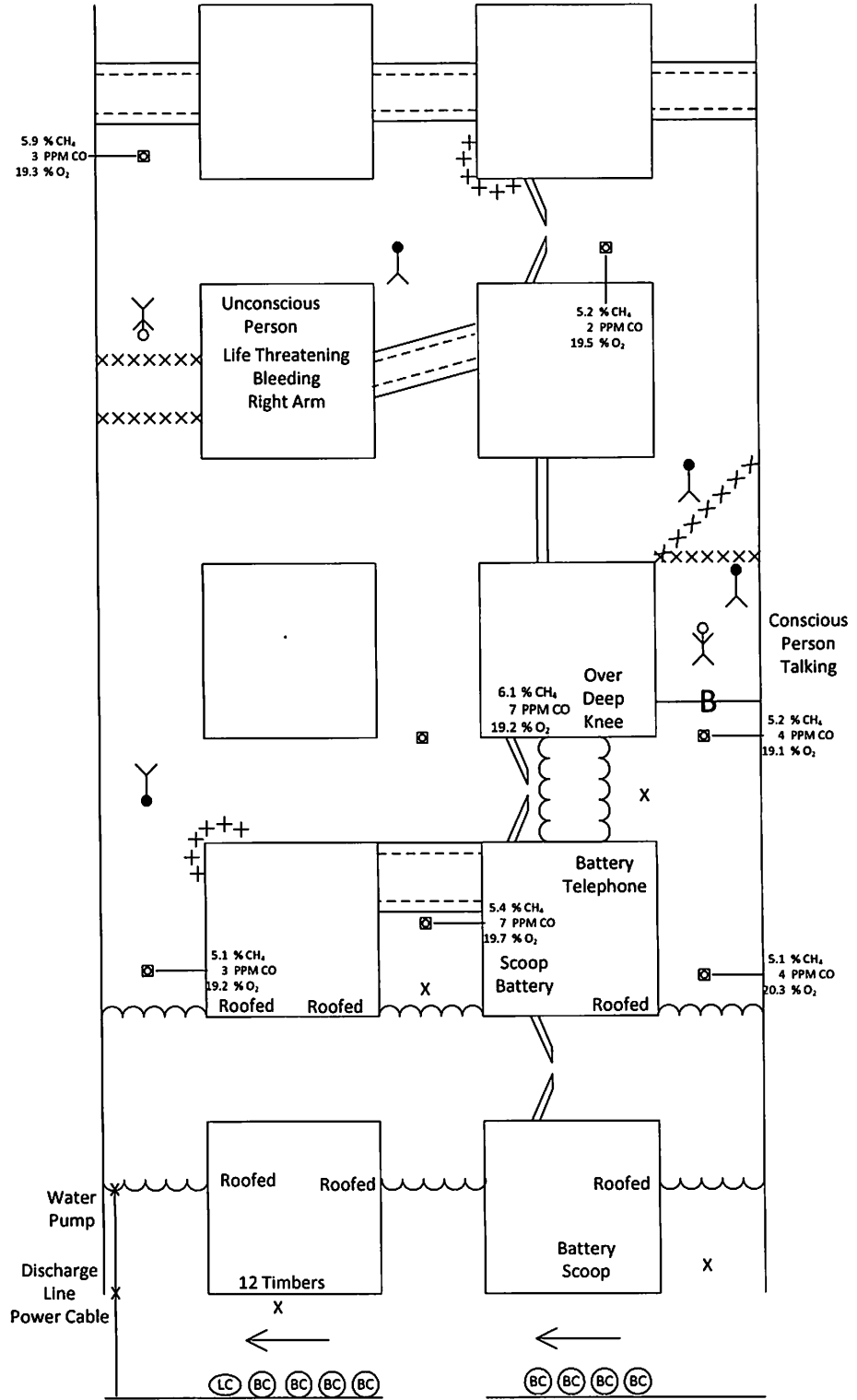

Ventilation 1 Day 1

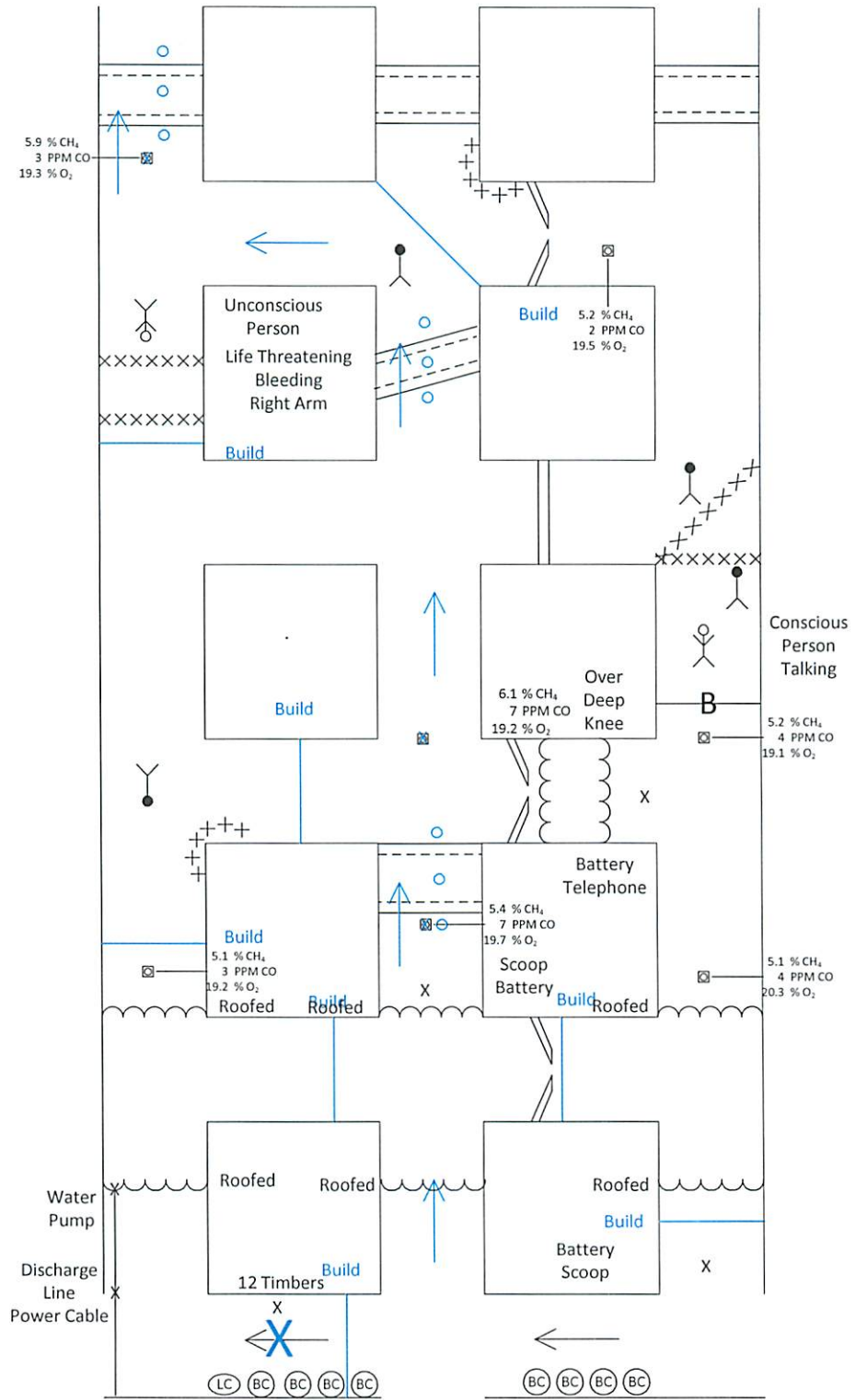

Ventilation 2 Day 1

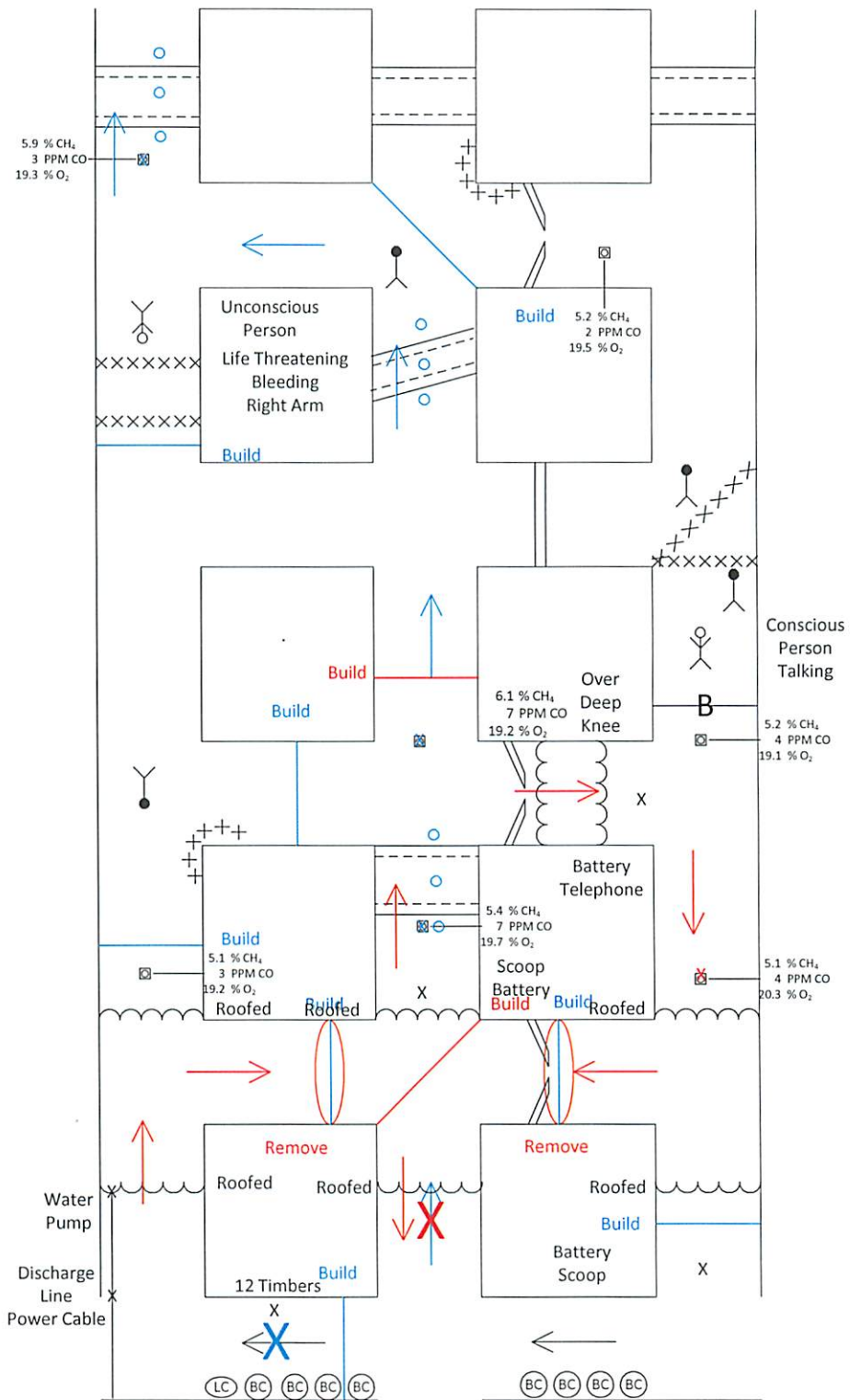



Ventilation 3 Day 1

