

POST 1 -2013

Thanks for answering our call for help. You will be located in the fresh-air-base of 4 Right sealed area.

Last night our company mine rescue team entered the sealed area through an air shaft located five cross cuts inby the fresh air base. We were going to recover the sealed area to utilize the air shaft for ventilation.

After the team traveled the first 50 feet and had their apparatus checks, communication with the five man mine rescue team was lost. We sent a couple of electricians down the shaft to trouble shoot the communication cable. A short time later they called outside and said a rock fall had occurred at the bottom of the shaft and it was impassable.

4 Right was sealed off with water about one cross cut inby the fresh-air-base. Temporary stoppings were built and we have spent the last 48 hours pumping water. We believe the water to be passable.

The mine is ventilated by an exhaust fan on the surface. It must remain on to ventilate the rest of the mines and it cannot be reversed or stalled. Air is currently intaking up the #1 entry and returning down the #3 entry as indicated by placards in the fresh air base.

All power in this area is locked out and guarded. There is a back-up team on site. Good Luck!!!!!!

PROBLEM

*EXPLORE THE ENTIRE SEALED AREA

*ACCOUNT FOR THE FIVE MISSING MINE RESCUE TEAM MEMBERS AND BRING SURVIVORS TO THE FRESH AIR BASE

*ONCE A MISSING TEAM MEMBER IS LOCATED, IMMEDIATELY NOTIFY THE BRIEFING OFFICER OF HIS WORKING POSITION AND LOG IT ON THE BRIEFING OFFICER'S MAP ALONG WITH THEIR LOCATION (PRIOR TO LEAVING THAT TEAM STOP)

*TEAMS CAN ONLY CARRY 2 SETS OF BRATTICE CLOTHS

JUDGES BRIEFING

- 1) Temporary stopping in #3 in by fresh-air-base is on the corner and does not leave room to airlock
- 2) Team can make the unsafe roof in #1 before entering #2
- 3) Unconscious person in 1st cross cut between #1 & #2 must be under air before going through low O₂ in #1
- 4) Person in the partial unsafe roof in #3 – 2nd cross cut will be a body after timbering, also the team position placard will be turned over after timbering
- 5) After making barricade all missing persons will be accounted for, which will allow teams to ventilate low oxygen over unexplored areas
- 6) Teams must air lock to enter the barricade
- 7) Patient must be under air to travel through low O₂ in #2 in by 3rd cross cut
- 8) Timbers in the barricade will require teams to timber the partial unsafe roof in 2nd cross cut in #3

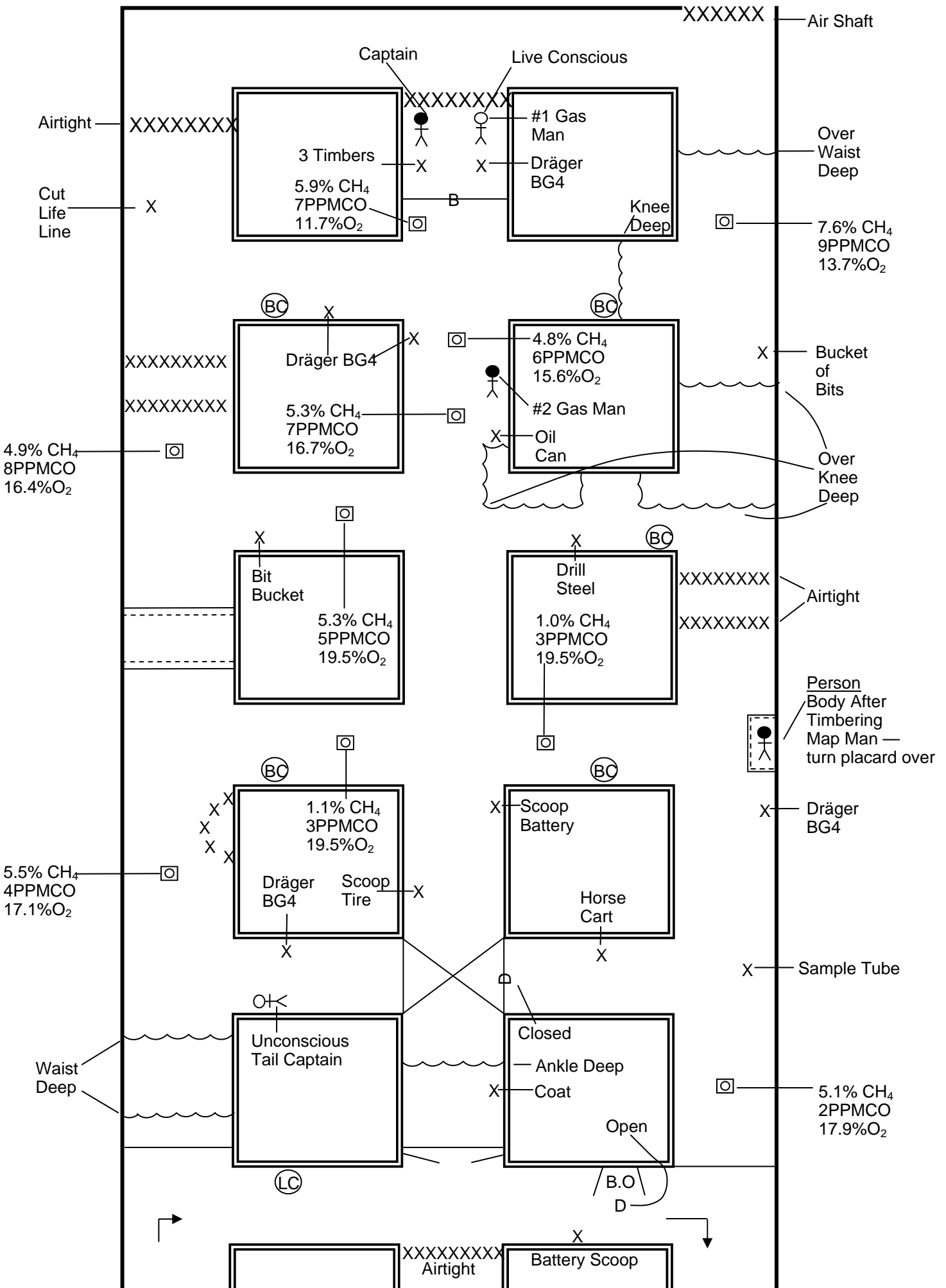

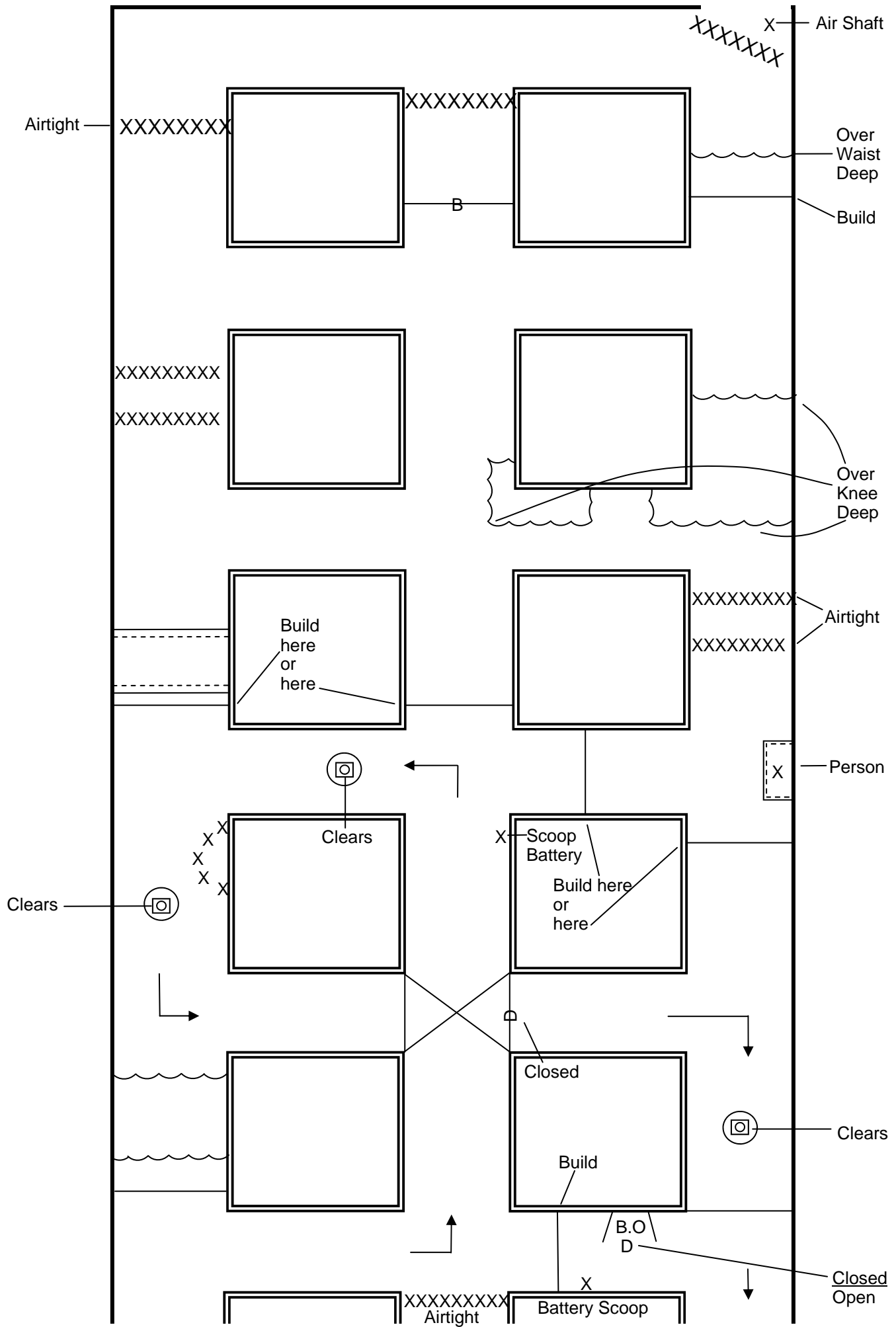

First Ventilation

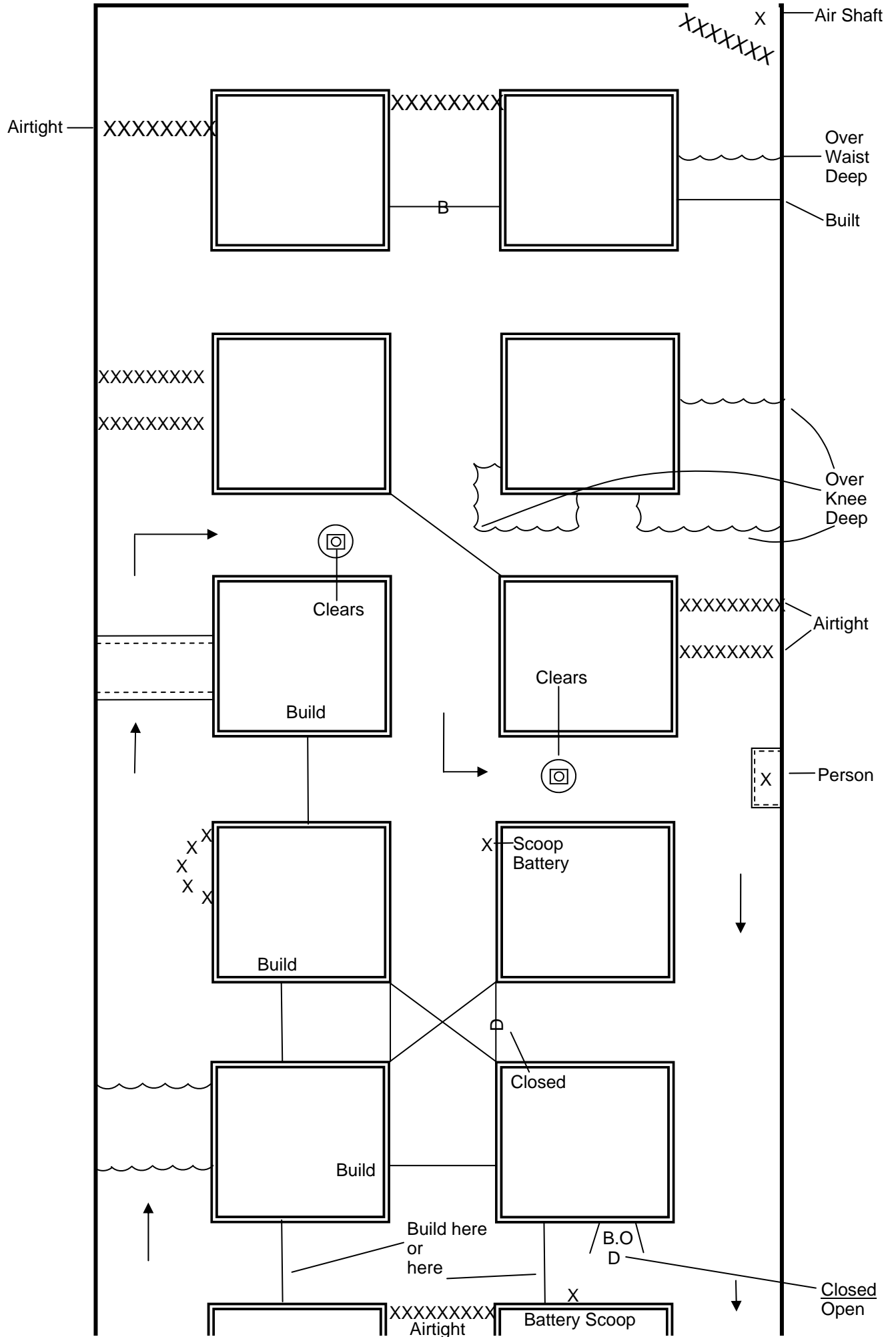

Second Ventilation

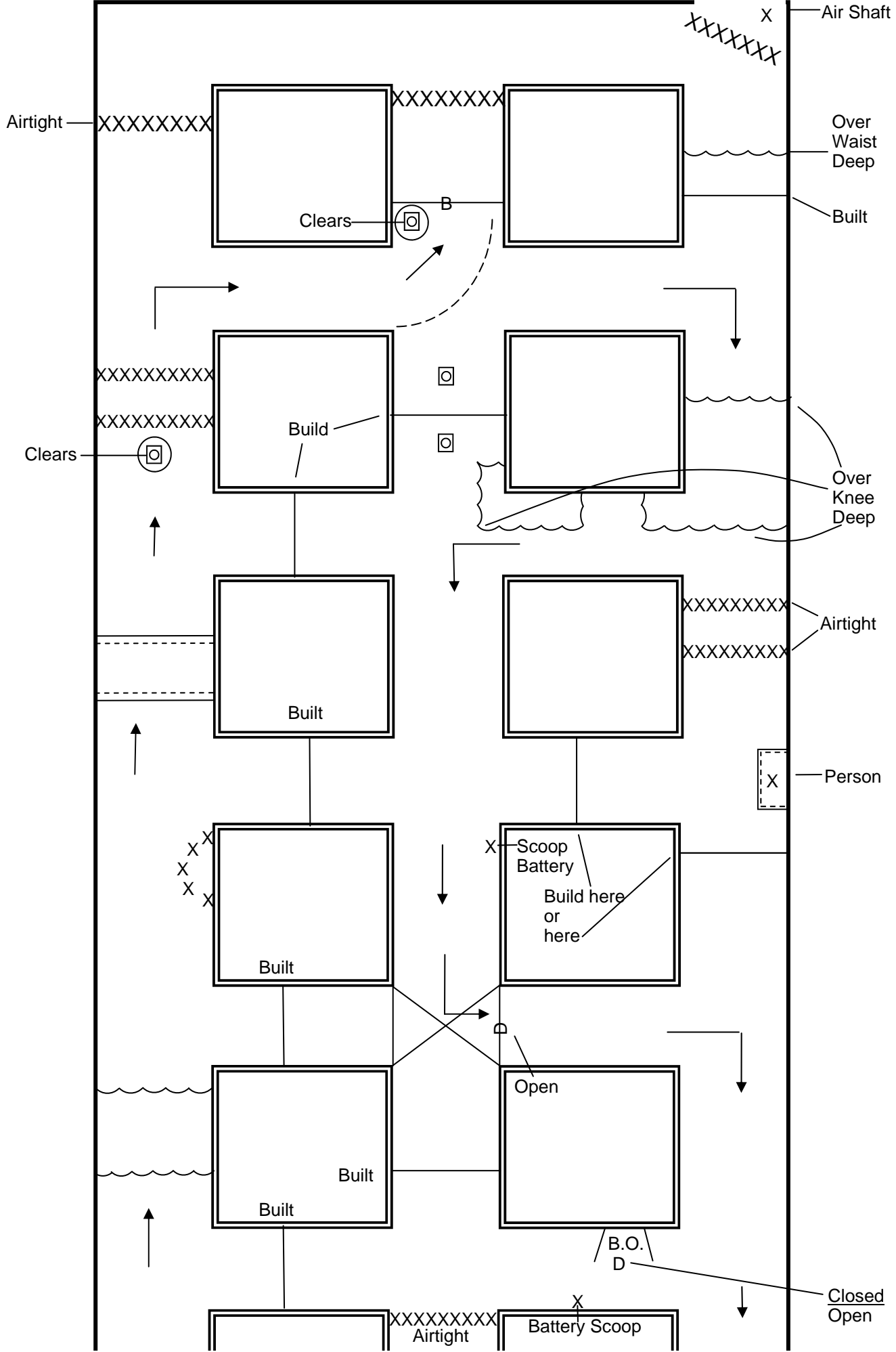

Third Ventilation

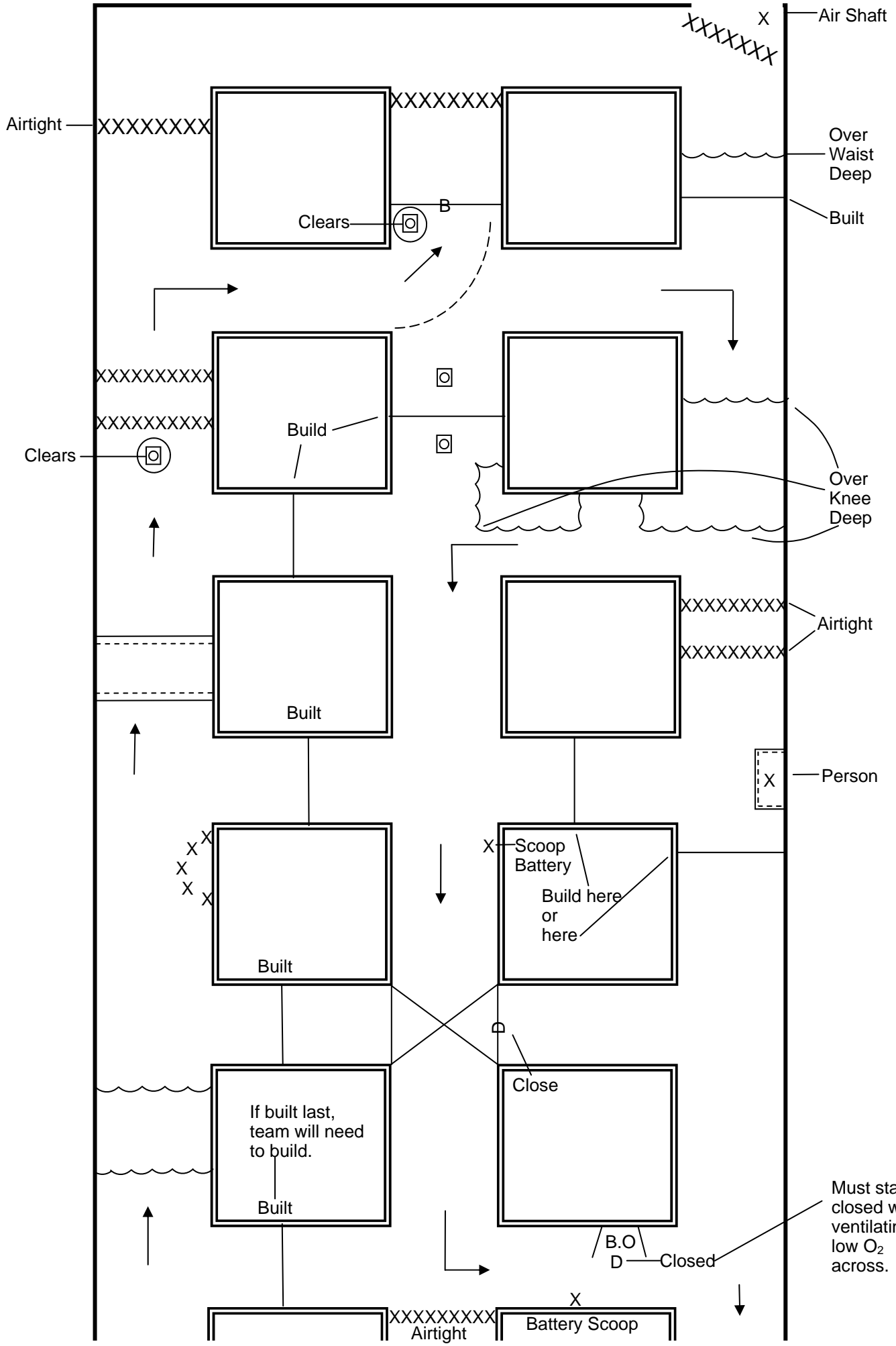

Alternative Third Ventilation

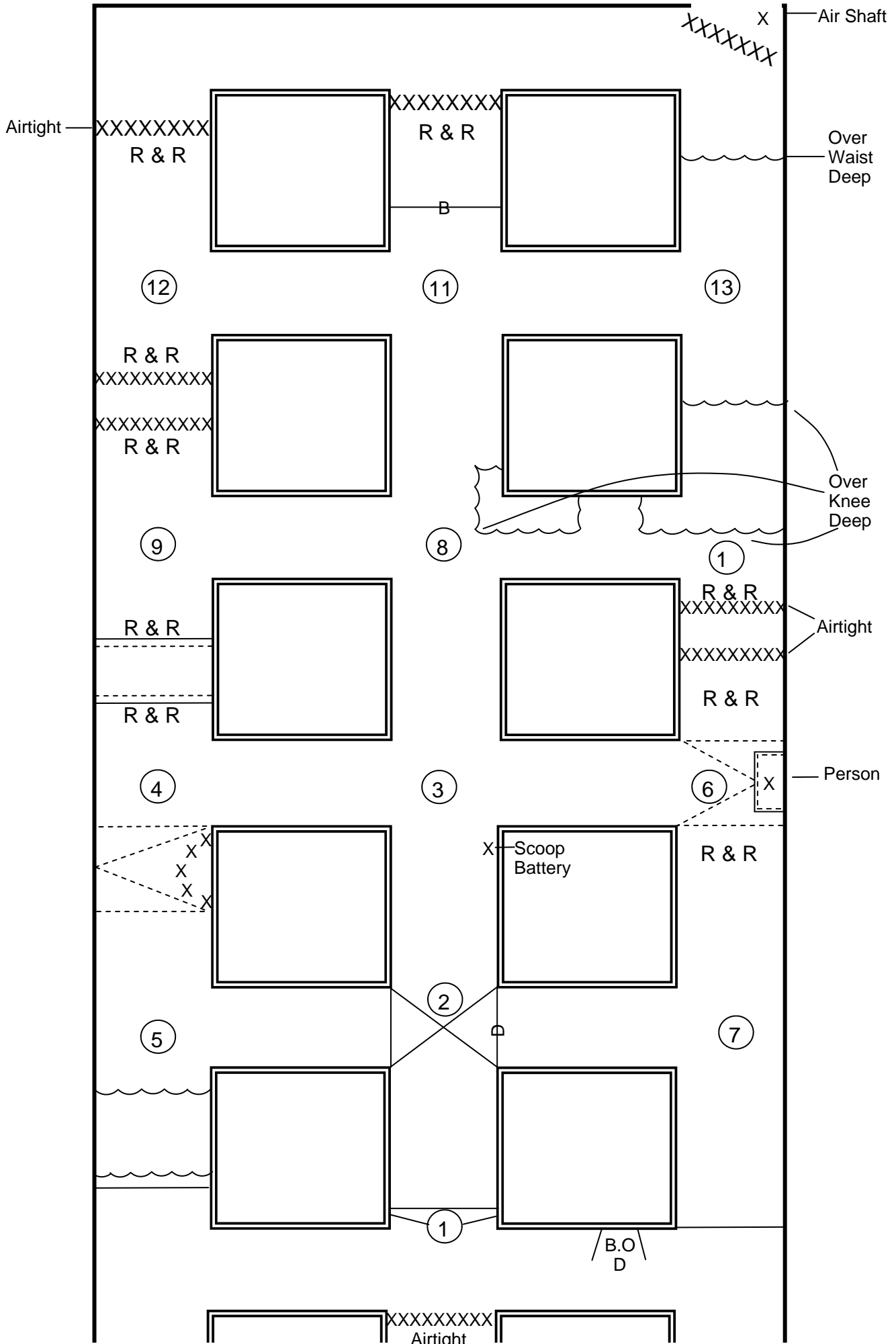

Team Travel and Roof & Ribs

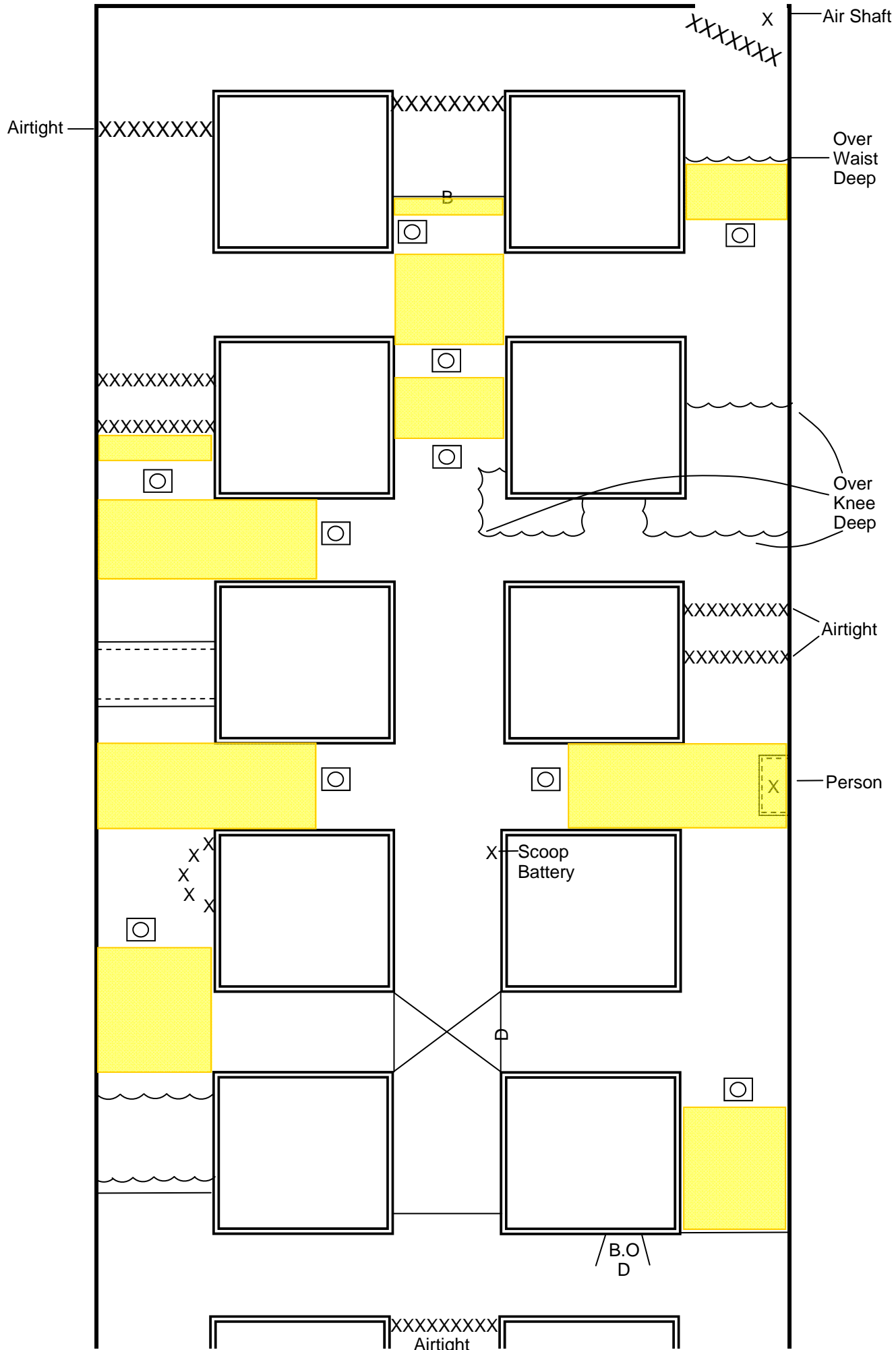

Extent of Gases

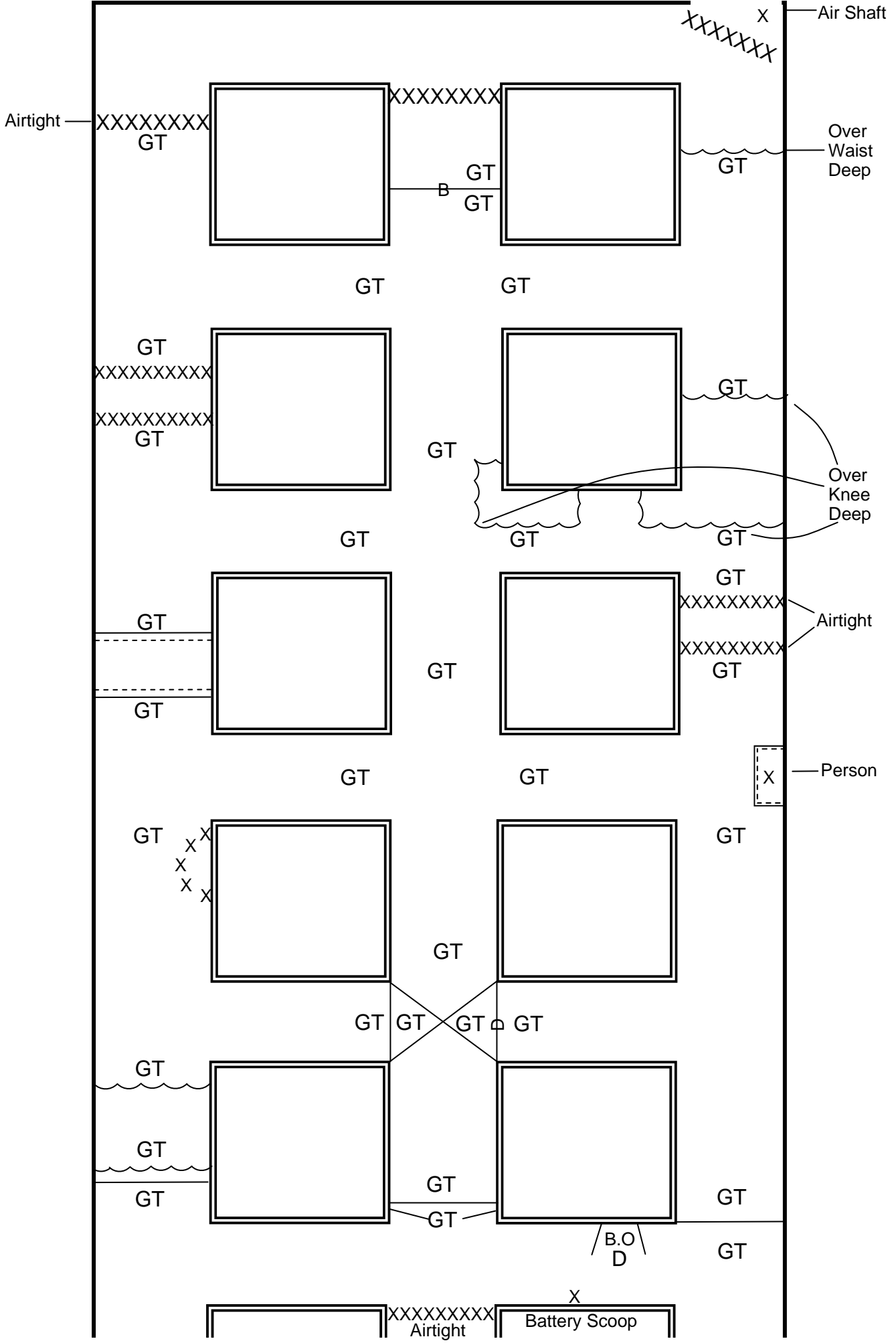

Gas Tests

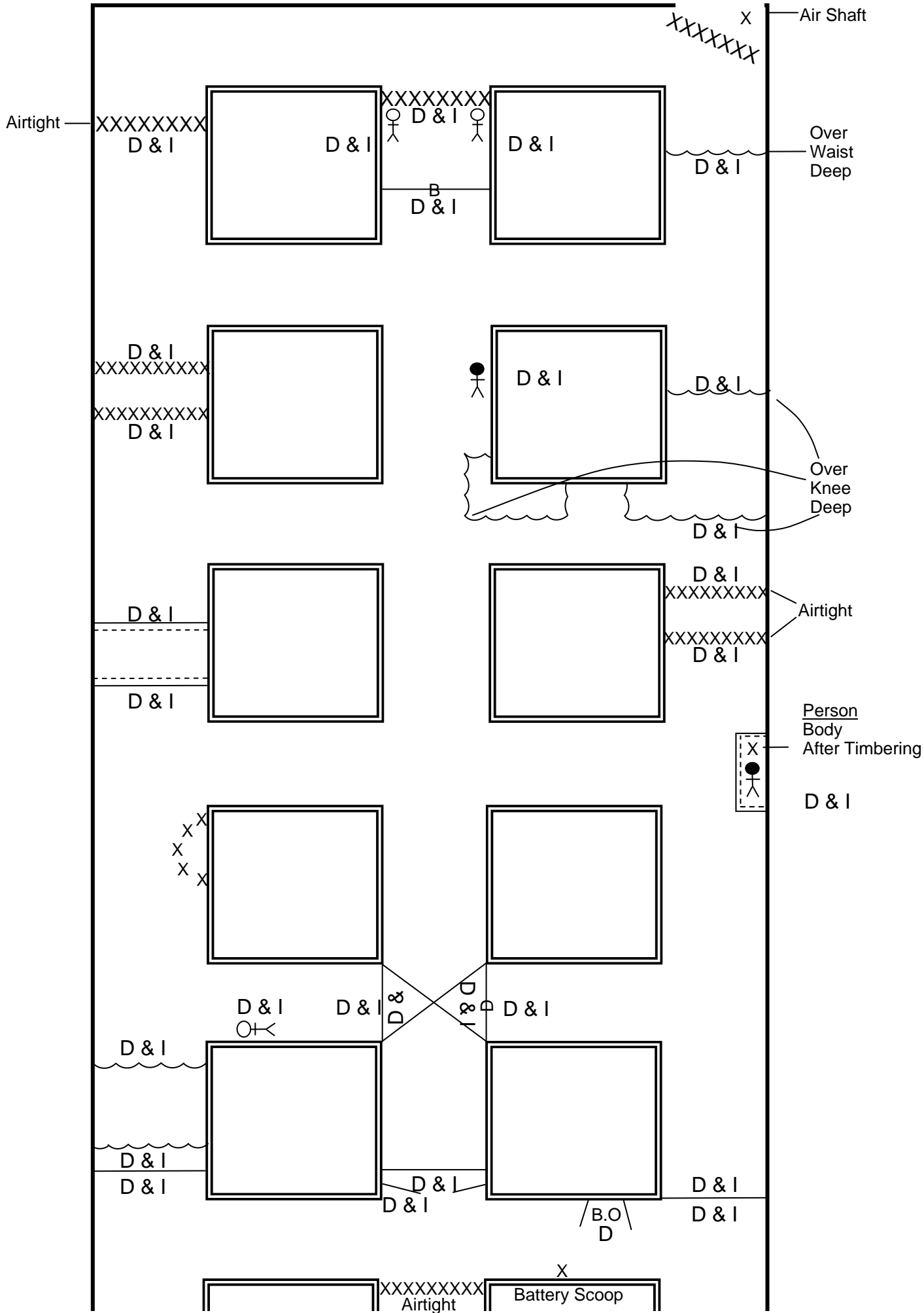

Dates & Initials

PATIENT

HELP GET US OUT

I'M IN HERE WITH MY CAPTAIN

I'M OK SO FAR, BUT HE IS

FEELING SICK

THERE IS A CAVED AREA

BEHIND US