

A Guide to Machine Safeguarding



Occupational Safety and Health Division
N.C. Department of Labor
1101 Mail Service Center
Raleigh, NC 27699-1101

Cherie Berry
Commissioner of Labor

**N.C. Department of Labor
Occupational Safety and Health Program**

Cherie Berry
Commissioner of Labor
OSHA State Plan Designee

Allen McNeely
Deputy Commissioner for Safety and Health

Kevin Beauregard
Assistant Deputy Commissioner for Safety and Health

Bobby Davis
Reviewer

Acknowledgments

This edition of *A Guide to Machine Safeguarding* has been updated with material originally prepared in OSHA Publication 3067 (U.S. Department of Labor, Occupational Safety and Health Administration), *Concepts and Techniques of Machine Safeguarding*. OSHA Publication 3067 is reprinted in part within this guide with the permission of the U.S. Department of Labor for use by the N.C. Department of Labor. This guide also contains information provided by U.S. Department of Health and Human Services, National Institute for Occupational Safety and Health. In addition, this publication was also supplemented by a limited number of written explanations and illustrations from *The Principles and Techniques of Mechanical Guarding* (Occupational Safety and Health Administration of the Arkansas Department of Labor); *Injuries and Amputations Resulting From Work With Mechanical Power Presses* (NIOSH Publication No. 87-107); and the *Health and Safety Guide for the Tanning Industry* (NIOSH Publication No. 77-101). Some changes have been made to reflect the North Carolina experience. The information in this guide was updated in 2013.

This guide is intended to be consistent with all existing OSHA standards; therefore, if an area is considered by the reader to be inconsistent with a standard, then the OSHA standard should be followed.

To obtain additional copies of this guide, or if you have questions about N.C. occupational safety and health standards or rules, please contact:

**N.C. Department of Labor
Education, Training and Technical Assistance Bureau
1101 Mail Service Center
Raleigh, NC 27699-1101**

Phone: 919-807-2875 or 1-800-NC-LABOR (1-800-625-2267)

Additional sources of information are listed on the inside back cover of this guide.

The projected cost of the NCDOL OSH program for federal fiscal year 2012–2013 is \$18,073,694. Federal funding provides approximately 30.5 percent (\$5,501,500) of this total.



Contents

Part		Page
	Foreword	iv
	Introduction	v
1	Basics of Machine Safeguarding	1
2	Methods of Machine Safeguarding	9
3	Guard Construction (and special notice of abrasive wheel guards and of power press guards)	55
4	Machinery Maintenance and Repair	59
5	Cooperation and Assistance	63
	Checklist	64

Foreword

Unguarded machinery claims far too many limbs and lives from North Carolina's working people. Such tragedies can be avoided by better training for machine operators, and most importantly, by making machines in the workplace safer.

This guide examines dozens of possible ways to safeguard machinery. There is even a machine safety checklist in the back of the book so the reader can see how his or her own workplace rates. *A Guide to Machine Safeguarding* also explains many issues related to making workplaces safer.

In North Carolina, state inspectors enforce the federal Occupational Safety and Health Act (OSHA) through a state plan approved by the U.S. Department of Labor. The N.C. Department of Labor's Occupational Safety and Health Division is charged with this mission. NCDOL offers many educational programs to the public and produces publications, including this guide, to help inform people about their rights and responsibilities regarding occupational safety and health.

When looking through this guide, please remember that NCDOL's mission is greater than just to enforce regulations. An equally important goal is to help citizens find ways to create safe workplaces. Everyone profits when managers and employees work together for safety. This booklet, like the other educational materials produced by the N.C. Department of Labor, can help.

Reading and understanding *A Guide to Machine Safeguarding* will help you form a sound occupational safety and health policy where you work.

Cherie Berry
Commissioner of Labor

Introduction

This industry guide has been prepared as an aid to employers, employees, machine manufacturers, machine guard designers and fabricators, and all others with an interest in protecting workers against the hazards of moving machine parts. It identifies the major mechanical motions and actions, and the general principles of safeguarding them.

The basic types of mechanical action or motion that must be guarded are found in many machines in many industries. Current applications of each technique are shown in accompanying illustrations of specific operations and machines. The concepts described here may, with due care, be transferred to different machines with similar motions. Any moving part creates a hazard and guarding eliminates or controls the hazard. However, this guide does not attempt to discuss all possible approaches to machine safeguarding.

For particular areas of concern, the reader should consult additional sources of information. Two topics that demand further research on the reader's part are safeguarding practices and procedures during the maintenance of machinery and safeguards for robotic machinery.

- Injuries from machinery undergoing maintenance are numerous. Preventing such injuries from occurring during machine maintenance requires further study on the reader's part.
- Although robotic machinery is relatively new, its use is expanding at a fast pace. Therefore, safeguarding for robotic machinery demands additional research efforts.

In machine safeguarding, as in other regulated areas of the American workplace, to a certain extent, Occupational Safety and Health Administration standards govern function and practice. This text is not a substitute for OSHA standards. For OSHA standards regarding machine guards, the reader should refer to *North Carolina OSHA Standards for General Industry* (Subpart O—Machinery and Machine Guarding).

This is a manual of basic technical information and workable ideas that the employer may use as a guide to voluntary compliance. By understanding the basic techniques for guarding simple machinery, one is better able to cope with the problems involving more complex machinery. This guide offers an overview of the machine safeguarding problem in its industrial setting, an assortment of solutions in popular use, and a challenge to all whose work involves machines.

Many readers of this guide already have the judgment, knowledge and skill to develop effective answers to problems yet unsolved. Innovators are encouraged to use this guide to help them find new ways to eliminate hazards by properly guarding the machines used by North Carolina employees.

Though this guide is intended to be consistent with OSHA standards, if an area is considered by the reader to be inconsistent, the OSHA standard should be followed.

Hazards Associated With Machine Safeguarding

Moving machine parts have the potential for causing severe workplace injuries, such as crushed fingers or hands, amputations, burns, and blindness, just to name a few. Safeguards are essential for protecting workers from these needless and preventable injuries. Machine guarding and related machinery violations continuously rank among the top 20 of OSHA citations issued. In fact, “Machine Guarding: General Requirements” (1910.212) and “Mechanical Power Transmission” (1910.219) were the No. 3 and No. 8 top OSHA violations for FY 2009, with 2,045 and 1,268 federal citations issued, respectively. Mechanical power presses have also become an area of increasing concern. In April 1997, OSHA launched a National Emphasis Program on Mechanical Power Presses (CPL 2-1.24). This program targets industries that have high amputation rates and includes both education and enforcement efforts. Following that Program, on March 26, 2002, OSHA implemented OSHA Instruction CPL 03-00-002 (previously known as CPL 2-1.35), National Emphasis Program on Amputations, in order to address additional machinery associated with amputation hazards thereby reducing injuries.

For North Carolina in particular, during FY 2009 conditions cited by NCDOL for hazards related to machine guarding in manufacturing industry, the statistics reflect top 30 violations showed 1910.212 was No. 4 and 1910.215 (Abrasive Wheel Machinery) was ranked No. 9; 1910.215 (Mechanical power-transmission apparatus) was No. 15 during this period. The top 10 serious violation for general industry standards cited in FY 2009 consisted of the following machine guarding related issues:

#1 Missing Machine Guard

- 1910.212(a)(1) General requirements for all machines—Machine guarding. Types of guarding—One or more methods of machine guarding shall be provided to protect the operator and other employees in the machine area from hazards such as those created by point of operation, ingoing nip points, rotating parts, flying chips and sparks.

#2 Bench Grinder Tongue Guard out of Adjustment

- 1910.215(b)(9) Guarding of abrasive wheel machinery. The peripheral protecting member (guard) shall be provided and adjusted within ¼ inch of the wheel to contain and deflect fragments away from the operator.

#3 Bench Grinder Work Rest out of Adjustment

- 1910.215(a)(4) Abrasive wheel machinery—General requirements. Work rests—on offhand grinding machines, work rests shall be used to support the work.... Work rests shall be kept adjusted closely to the wheel with a maximum opening of ⅛ inch to prevent work from being jammed between wheel and rest....

#10 Point of Operation Machine Guarding

- 1910.212(a)(3) General requirements for all machines—Machine guarding. Point of operation of machines whose operation exposes an employee to injury shall be guarded.... Special handtools for placing and removing material shall permit easy handling of material without the operator placing a hand in the danger zone.

Overall Top 10 Violations Most Frequently Cited Serious for General Industry Standards During FY 2009:

1. **1910.212(a)(1)—Machine guarding—General requirements**
2. **1910.215(b)(9)—Machine guarding—Abrasive wheel machinery—Exposure adjustment**
3. **1910.215(a)(4)—Machine guarding—Abrasive wheel machinery—Work rest adjustment**
4. 1910.151(c)—Medical and first aid—Eyewash and safety showers
5. NCGS 95-129(1)—North Carolina General Duty Clause
6. 1910.304(g)(5)—Electrical—Grounding—Path to ground
7. 1910.133(a)(1)—Eye and face protection—General requirements
8. 1910.305(b)(1)(ii)—Electrical cabinets, boxes and fittings—Unused openings effectively closed
9. 1910.23(c)(1)—Walking/Working surfaces—Open sided floors/platforms 4 feet or more above adjacent ground require standard railings
10. **1910.212(a)(3)(ii)—Machine guarding—Point of operation guarding**

Deaths and Injuries in North Carolina Associated With Machine Safeguarding Problems

The absence of proper safeguarding of machinery is a major cause of injuries to employees in North Carolina. The following list provides examples of such injuries.

- *An employee was killed by the unguarded tenter frame he operated. He was a doffer for a textile company in Greensboro, N.C. He was fatally injured when he leaned into an unguarded area of the machine to untangle a piece of cloth from the rollers. The transfer unit sides of the machine closed on the employee's head, causing his death.*
- *An employee's middle and index fingers were amputated from his right hand after he was injured by an unguarded 60 ton punch press. He was employed as a punch-press operator by a manufacturer in Burlington, N.C.*
- *An employee's left arm was severed at her elbow by the unguarded meat-grinding machine she was operating. Not only was the chute of the meat grinder unguarded, but there was no push stick available to distance her hands from the point of operation. The auger of the grinder grabbed the employee's fingers and continuously pulled her hand and arm into the machine. She was 19 years old. She was an employee of a grocery store in Fuquay-Varina, N.C.*
- *Two of the fingers on an employee's left hand were removed after he was injured by a mechanical power press. The employee, then 19, was employed by a metal fabricating company in Wilmington, N.C. The employee's operating procedure was to place pieces of metal into the point of operation, then cause the ram of the machine to descend, by depressing a push-button trip that could be activated with only one hand. The press cycled as the employee removed a piece of metal from the point of operation.*
- *Emergency surgery was required to remove a piece of wood from an employee's stomach. The wood was driven into his stomach after splintering from lumber running through the edger that he operated. The employee was employed in a sawmill in Mount Airy, N.C.*
- *An employee's left index finger was severed by a mechanical power press. She was not adequately trained to make certain that the point of operation was guarded prior to operating the press. The injury occurred when she used her hand to remove a part from the die of the unguarded press. She was 29 years old when she was injured on her job. She worked for a manufacturer in Dunn, N.C.*
- *An employee, 49, lost a finger to the unguarded cigarette-making machine that he operated. He was employed by a tobacco company in Winston-Salem, N.C.*
- *An employee had two fingers amputated after being injured by a mechanical power press. He was employed in a factory as a set-up man. The injury occurred as he was checking the parts produced by the machine following his set-up of the press die.*

Basics of Machine Safeguarding

Crushed hands and arms, severed fingers, blindness—the list of possible machinery-related injuries is as long as it is horrifying. There seem to be as many hazards created by moving machine parts as there are types of machines. Safeguards are essential for protecting workers from needless and preventable injuries.

A good rule to remember is: *Any machine part, function or process that may cause injury must be safeguarded.* Where the operation of a machine or accidental contact with it can injure the operator or others in the vicinity, the hazard must be either eliminated or controlled.

This guide describes the various hazards of mechanical motion and action and presents some techniques for protecting workers from these hazards. General information is covered in this chapter: where mechanical hazards occur, the kinds of motions that need safeguarding, the requirements for effective safeguards, a brief discussion of nonmechanical hazards, and some other considerations.

Where Mechanical Hazards Occur

Dangerous moving parts in these three basic areas need safeguarding:

The Point of Operation

The point of operation is that point where work is performed on the material, such as cutting, shaping, boring or forming of stock.

Power Transmission Apparatus

Power transmission apparatus are all components of the mechanical system that transmit energy to the part of the machine performing the work. These components include flywheels, pulleys, belts, connecting rods, couplings, cams, spindles, chains, cranks and gears.

Other Moving Parts

Other moving parts include all parts of the machine that move while the machine is working. These can be reciprocating, rotating and transverse moving parts, as well as feed mechanisms and auxiliary parts of the machine.

Hazardous Mechanical Motions and Actions

A wide variety of mechanical motions and actions may present hazards to the worker. These can include the movement of rotating members, reciprocating arms, moving belts, meshing gears, cutting teeth, and any parts that impact or shear. These different types of hazardous mechanical motions and actions are basic to nearly all machines, and recognizing them is the first step toward protecting workers from the danger they present.

The basic types of hazardous mechanical motions and actions are:

(Motions)

- rotating (including in-running nip points)
- reciprocating
- transverse

(Actions)

- cutting
- punching
- shearing
- bending

We will briefly examine each of these basic types.

Motions

Rotating Motion

Rotating motion can be dangerous; even smooth, slowly rotating shafts can grip clothing, and through mere skin contact, force an arm or hand into a dangerous position. Injuries due to contact with rotating parts can be severe.

Collars, couplings, cams, clutches, flywheels, shaft ends, spindles, and horizontal or vertical shafting are some examples of common rotating mechanisms that may be hazardous. The danger increases when bolts, nicks, abrasions, and projecting keys or set screws are exposed on rotating parts. See Figure 1.

Figure 1

Examples of Typical Rotating Mechanisms

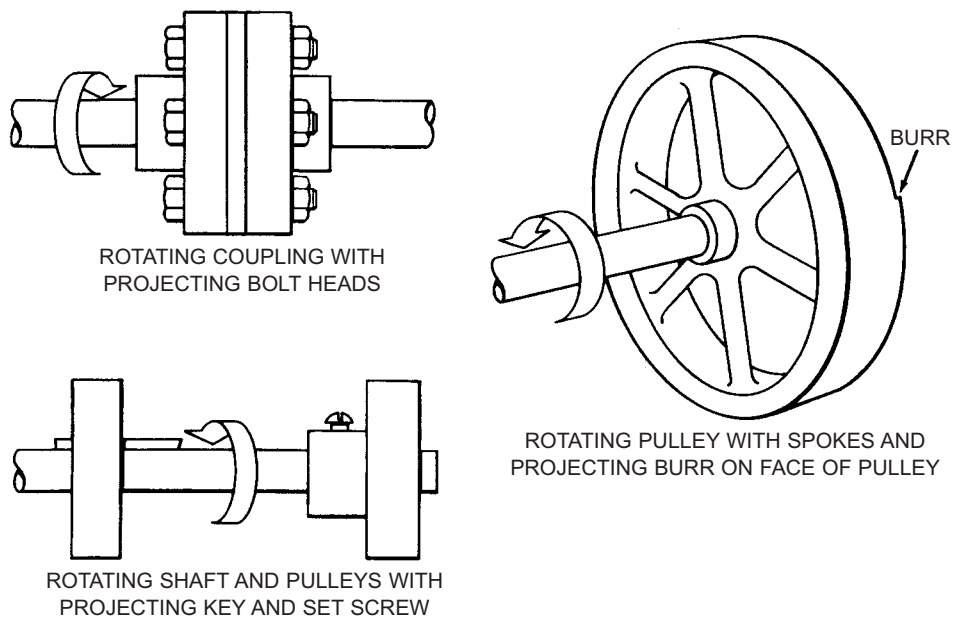

In-running nip point hazards are caused by the rotating parts on machinery. There are three main types of in-running nips.

Parts can rotate in opposite directions while their axes are parallel to each other. These parts may be in contact (producing a nip point) or in close proximity to each other. In the latter case, the stock fed between the rolls produces the nip points. This danger is common on machinery with intermeshing gears, rolling mills and calenders. See Figure 2.

Figure 2

Examples of In-running Nip Points—Parallel Axes, Rotation in Opposite Directions

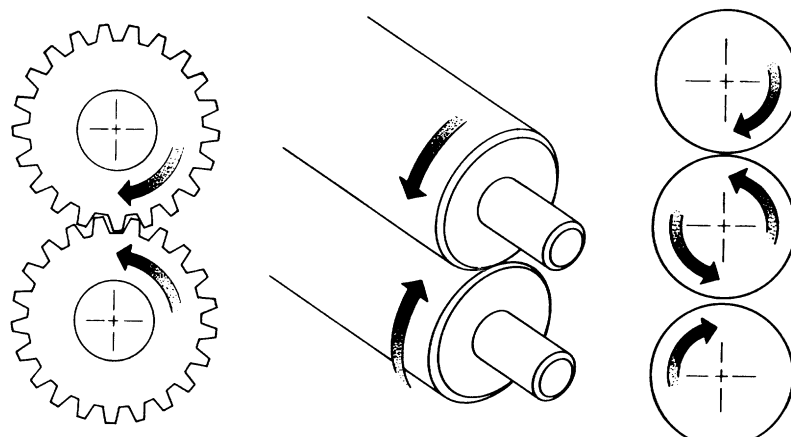

Another nip point is created between rotating and tangentially moving parts. Some examples would be: the point of contact between a power transmission belt and its pulley, a chain and a sprocket, or a rack and pinion. See Figure 3.

Figure 3

Examples of In-running Nip Points—Rotating and Tangentially Moving Parts

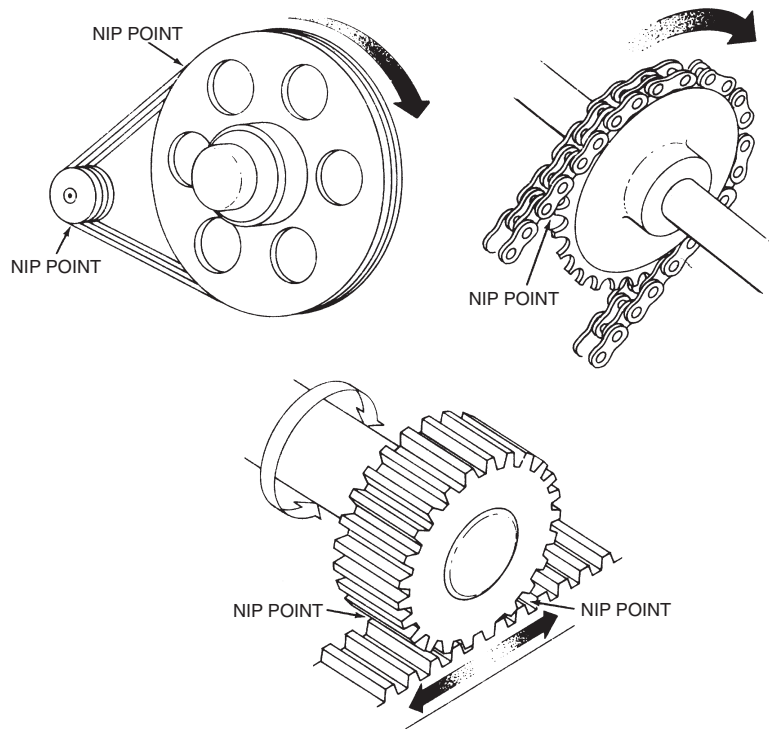

Nip points can occur between rotating and fixed parts that create a shearing, crushing or abrading action. Examples are spoked handwheels or flywheels, screw conveyors, or the periphery of an abrasive wheel and an incorrectly adjusted work rest. See Figure 4.

Figure 4

Examples of In-Running Nip Points—Shearing, Crushing, Abrading Actions

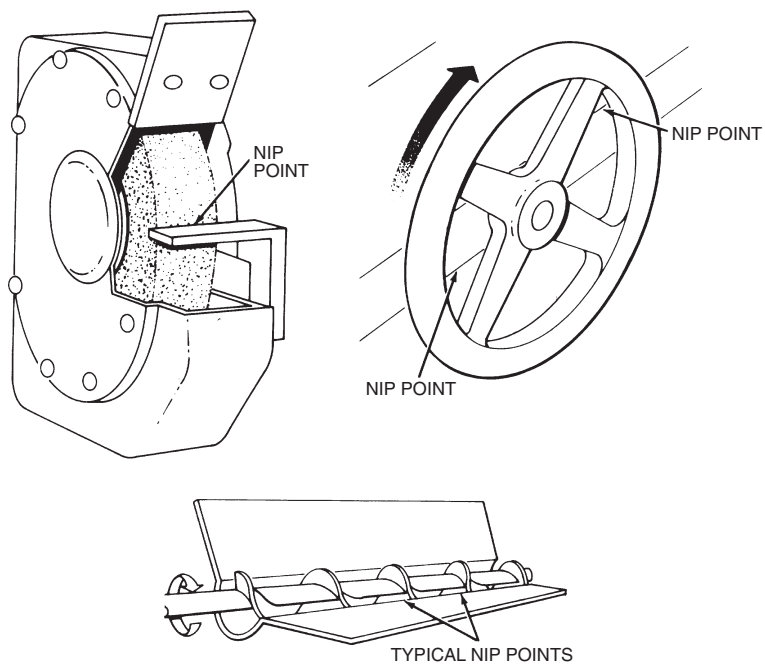

Reciprocating Motion

Reciprocating motions may be hazardous because, during the back-and-forth or up-and-down motion, a worker may be struck by or caught between a moving and a stationary part. See Figure 5.

Figure 5

Example of a Reciprocating Motion

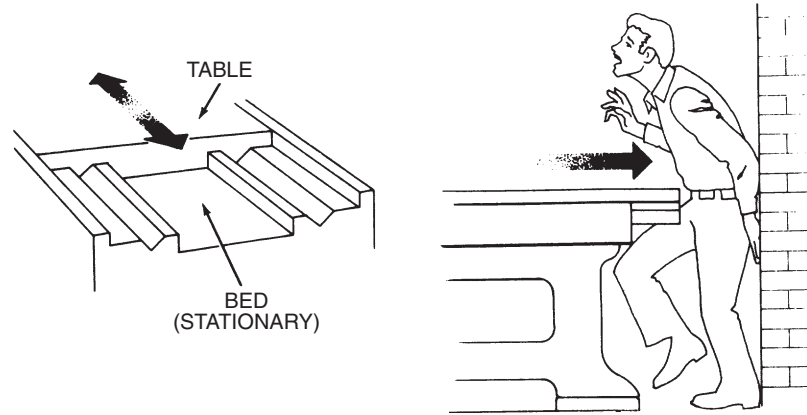

Transverse Motion

Transverse motion (movement in a straight, continuous line) creates a hazard because a worker may be struck or caught in a pinch or shear point by the moving part, or caught and dragged by the part's motion. See Figure 6.

Figure 6

Example of a Transverse Motion

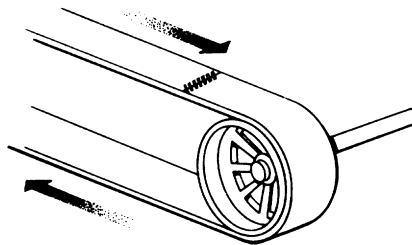

Actions

Cutting Action

Cutting action involves rotating, reciprocating or transverse motion. The danger of cutting action exists at the point of operation where finger, head and arm injuries can occur and where flying chips or scrap material can strike the eyes or face. Such hazards are present at the point of operation in cutting wood, metal or other materials. Typical examples of mechanisms involving cutting hazards include band saws, circular saws, boring or drilling machines, turning machines (lathes), or milling machines. See Figure 7.

Figure 7

Examples of Cutting Actions That Can Present Hazards

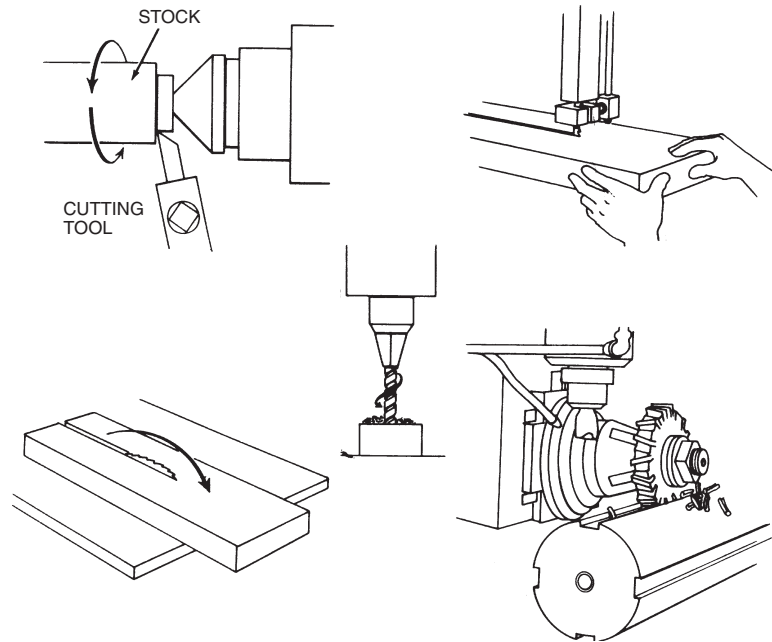

Punching Action

Punching action results when power is applied to a slide (ram) for the purpose of blanking, drawing or stamping metal or other materials. The danger of this type of action occurs at the point of operation where the stock is inserted, held and withdrawn by hand.

Typical machinery used for punching operations are power presses and iron workers. See Figure 8.

Figure 8

Example of a Punching Operation

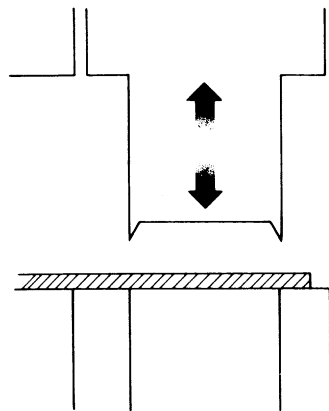

Shearing Action

Shearing action involves applying power to a slide or knife in order to trim or shear metal or other materials. A hazard occurs at the point of operation where stock is actually inserted, held and withdrawn.

Typical examples of machinery used for shearing operations are mechanically, hydraulically or pneumatically powered shears. See Figure 9.

Figure 9

Example of a Shearing Action

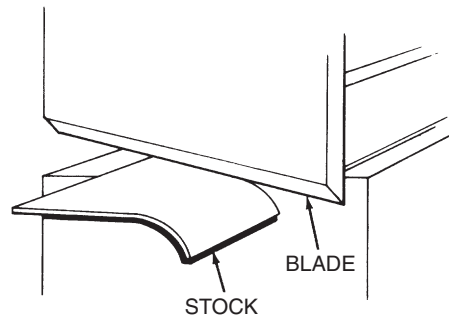

Bending Action

Bending action results when power is applied to a slide in order to draw or stamp metal or other materials, and a hazard occurs at the point of operation where stock is inserted, held and withdrawn.

Equipment that uses bending action includes power presses, press brakes and tubing benders. See Figure 10.

Figure 10

Example of a Bending Operation

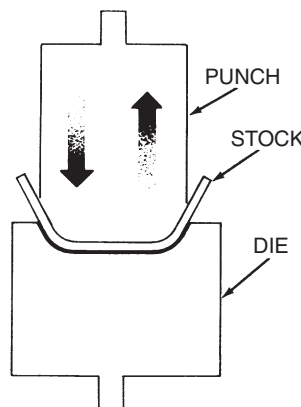

Requirements for Safeguards

What must a safeguard do to protect workers against mechanical hazards? Safeguards must meet these minimum general requirements:

Prevent Contact

The safeguard must prevent hands, arms or any other part of a worker's body from making contact with dangerous moving parts. A good safeguard system eliminates the possibility of the operator or another worker placing his or her hands near hazardous moving parts.

Be Secured to the Machine

Workers should not be able to remove or tamper easily with the safeguard, because a safeguard that can easily be made ineffective is no safeguard at all. Guards and safety devices should be made of durable material that will withstand the conditions of normal use. They must be firmly secured to the machine.

Protect From Falling Objects

The safeguard should ensure that no objects can fall into moving parts. A small tool that is dropped into a cycling machine could easily become a projectile that could strike and injure someone.

Not Create New Hazards

A safeguard defeats its own purpose if it creates a hazard of its own, such as a shear point, a jagged edge or an unfinished surface that can cause a laceration. The edges of guards, for instance, should be rolled or bolted in such a way that they eliminate sharp edges.

Not Interfere With Job Performance

Any safeguard that impedes a worker from performing the job quickly and comfortably might soon be overridden or disregarded. Proper safeguarding can actually enhance efficiency since it can relieve the worker's apprehensions about injury.

Allow for Safe Lubrication of the Machine

If possible, one should be able to lubricate the machine without removing the safeguards. Locating oil reservoirs outside the guard, with a line leading to the lubrication point, will reduce the need for the operator or maintenance worker to enter the hazardous area.

Nonmechanical Hazards

While this manual concentrates attention on concepts and techniques for safeguarding mechanical motion, machines obviously present a variety of other hazards that cannot be ignored. Full discussion of these matters is beyond the scope of this publication, but some nonmechanical hazards are briefly mentioned below to remind the reader of factors other than safeguarding moving parts that can affect the safe operation of machinery.

All power sources for machinery are potential sources of danger. When using electrically powered or controlled machines, for instance, the equipment as well as the electrical system itself must be properly grounded. Replacing frayed, exposed or old wiring will also help to protect the operator and others from electrical shocks or electrocution. High pressure systems need careful inspection and maintenance to prevent possible failure from pulsation, vibration or leaks. Such a failure could cause explosions or flying objects.

Machines often produce noise (unwanted sound), and this can result in a number of hazards to workers. Not only can it startle and disrupt concentration, but it can interfere with communications, thus hindering the worker's safe job performance. Research has linked noise to a range of harmful health effects, from hearing loss and aural pain to nausea, fatigue, reduced muscle control and emotional disturbances. Engineering controls, such as the use of sound-dampening materials, as well as less sophisticated hearing protection, such as ear plugs and muffs, have been suggested as ways of controlling the harmful effects of noise. Vibration, a related hazard that can cause noise and thus result in fatigue and illness for the worker, may be avoided if machines are properly aligned, supported and, if necessary, anchored.

Because some machines require the use of cutting fluids, coolants and other potentially harmful substances, operators, maintenance workers and others in the vicinity may need protection. These substances can cause ailments ranging from dermatitis to serious illnesses and disease. Specially constructed safeguards, ventilation, and protective equipment and clothing are possible temporary solutions to the problem of machinery-related chemical hazards until those hazards can be better controlled or eliminated from the workplace.

Training

Even the most elaborate safeguarding system cannot offer effective protection unless the worker knows how to use it and why. Specific and detailed training is therefore a crucial part of any effort to provide safeguarding against machine-related hazards. Thorough operator training should involve instruction or hands-on training in the following:

1. A description and identification of the hazards associated with particular machines;
2. The safeguards themselves, how they provide protection and the hazards for which they are intended;
3. How to use the safeguards and why;
4. How and under what circumstances safeguards can be removed and by whom (in most cases, repair or maintenance personnel only); and
5. What to do (e.g., contact the supervisor) if a safeguard is damaged, missing or unable to provide adequate protection.

This kind of safety training is necessary for new operators and maintenance or setup personnel, when any new or altered safeguards are put in service, or when workers are assigned to a new machine or operation.

Protective Clothing and Personal Protective Equipment

Engineering controls, which control the hazard at the source and do not rely on the worker's behavior for their effectiveness, offer the best and most reliable means of safeguarding. Therefore, engineering controls must be the employer's first choice for controlling machinery hazards. But whenever an extra measure of protection is necessary, operators must wear protective clothing or personal protective equipment.

If it is to provide adequate protection, the protective clothing and equipment selected must always be:

1. Appropriate for the particular hazards.
2. Maintained in good condition.
3. Properly stored when not in use, to prevent damage or loss.
4. Kept clean and sanitary.

Protective clothing is, of course, available for different parts of the body. Hard hats can protect the head from the impact of bumps and falling objects when the worker is handling stock; caps and hair nets can help keep the worker's hair from being caught in machinery. If machinery coolants could splash or if particles could fly into the operator's eyes or face, then face shields, safety goggles, glasses or similar kinds of protection might be necessary. Hearing protection may be needed when workers operate noisy machinery. To guard the trunk of the body from cuts or impacts from heavy or rough-edged stock, there are certain protective coveralls, jackets, vests, aprons and full-body suits. Workers can protect their hands and arms from the same kinds of injury with special sleeves and gloves. And safety shoes and boots, or other acceptable foot guards, can shield the feet against injury in case the worker needs to handle heavy stock that might drop.

NOTE: It is important to note that protective clothing and equipment themselves can create hazards. A protective glove that can become caught between rotating parts, or a respirator facepiece that hinders the wearer's vision, for example, requires alertness and careful supervision whenever it is used.

Other aspects of the worker's dress may present additional safety hazards. Loose-fitting clothing might possibly become entangled in rotating spindles or other kinds of moving machinery. Jewelry, such as bracelets and rings, can catch on machine parts or stock and lead to serious injury by pulling a hand into the danger area.

2

Methods of Machine Safeguarding

There are many ways to safeguard machinery. The type of operation, the size or shape of stock, the method of handling, the physical layout of the work area, the type of material, and production requirements or limitations will help to determine the appropriate safeguarding method for the individual machine.

As a general rule, power transmission apparatus is best protected by fixed guards that enclose the danger area. For hazards at the point of operation, where moving parts actually perform work on stock, several kinds of safeguarding are possible. One must always choose the most effective and practical means available.

We can group safeguards under five general classifications:

1. Guards
 - A. Fixed
 - B. Interlocked
 - C. Adjustable
 - D. Self-adjusting
2. Devices
 - A. Presence Sensing
 - i. Photoelectric (optical)
 - ii. Radiofrequency (capacitance)
 - iii. Electromechanical
 - B. Pullback
 - C. Restraint
 - D. Safety Controls
 - i. Safety trip control
 - a. Pressure-sensitive body bar
 - b. Safety tripod
 - c. Safety tripwire cable
 - ii. Two-hand control
 - iii. Two-hand trip
 - E. Gates
 - i. Interlocked
 - ii. Other
3. Location/Distance
4. Potential Feeding and Ejection Methods to Improve Safety for the Operator
 - A. Automatic feed
 - B. Semi-automatic feed
 - C. Automatic ejection
 - D. Semi-automatic ejection
 - E. Robot
5. Miscellaneous Aids
 - A. Awareness barriers
 - B. Miscellaneous protective shields
 - C. Holding fixtures and hand-feeding tools

Guards

Guards are barriers that prevent access to danger areas. There are four general types of guards:

Fixed Guards

As its name implies, a fixed guard is a permanent part of the machine. It is not dependent upon moving parts to perform its intended function. It may be constructed of sheet metal, screen, wire cloth, bars, plastic or any other material that is substantial enough to withstand whatever impact it may receive and to endure prolonged use. This guard is usually preferable to all other types because of its relative simplicity and permanence.

In Figure 11, a fixed guard on a power press completely encloses the point of operation. The stock is fed through the side of the guard into the die area, with the scrap stock exiting on the opposite side.

Figure 11

Fixed Enclosure Guard on a Power Press

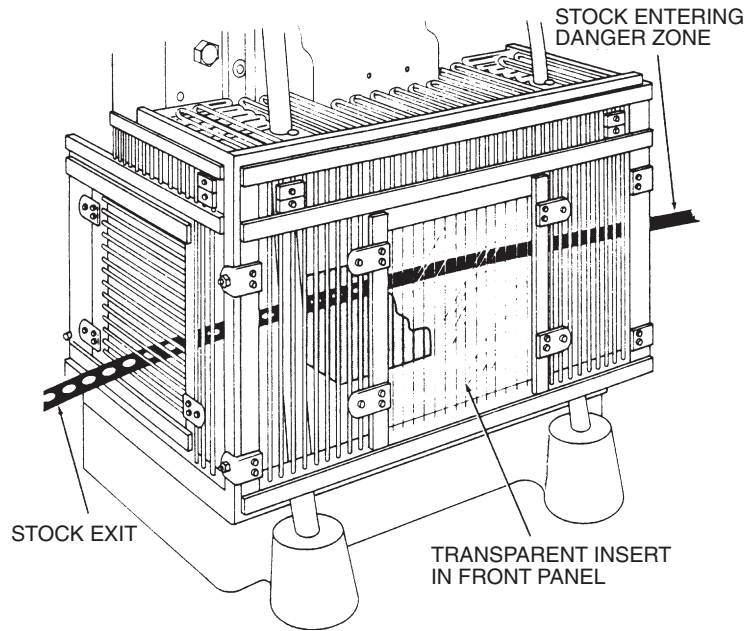
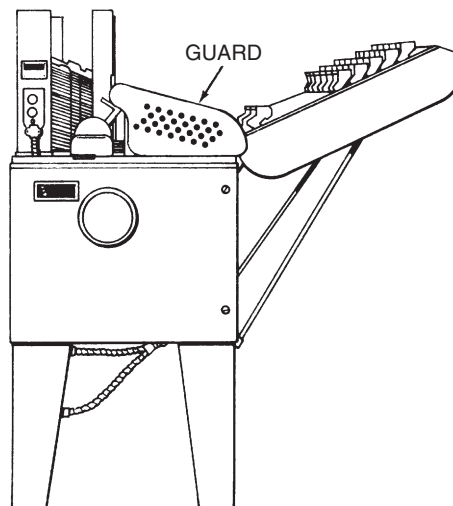

Figure 12 shows a fixed guard that protects the operator from a mechanism that folds cartons. This guard would not normally be removed except to perform maintenance on the machine.

Figure 12

Fixed Guard on Egg Carton Folding Machine



In Figure 13, fixed enclosure guards are shown on a band saw. These guards protect the operator from the turning wheels and moving saw blade. Normally the only time for the guards to be opened or removed would be for a blade change or maintenance. It is very important that they be securely fastened while the saw is in use.

Figure 13

Fixed Guard on a Band Saw

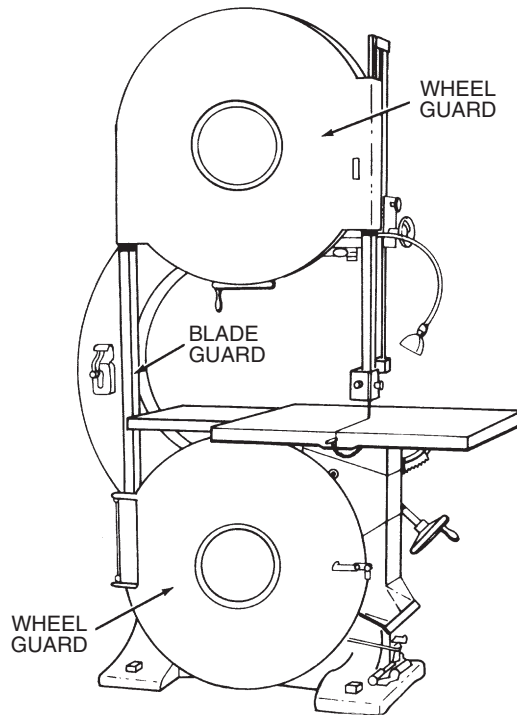
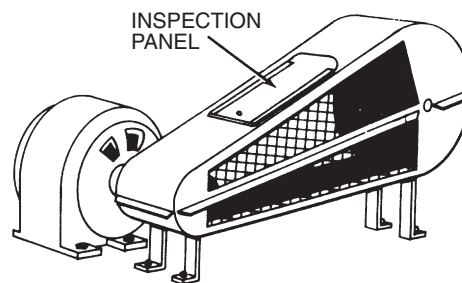

Figure 14 shows a fixed enclosure guard shielding the belt and pulley of a power transmission unit. An inspection panel is provided on top in order to minimize the need for removing the guard.

Figure 14

Fixed Guard Enclosing a Belt and Pulleys



In Figure 15, a transparent, fixed barrier guard is being used on a press brake to protect the operator from the unused portions of the die. This guard is relatively easy to install or remove.

Figure 15

Fixed Guard Providing Protection From Unused Portion of a Die on a Press Brake

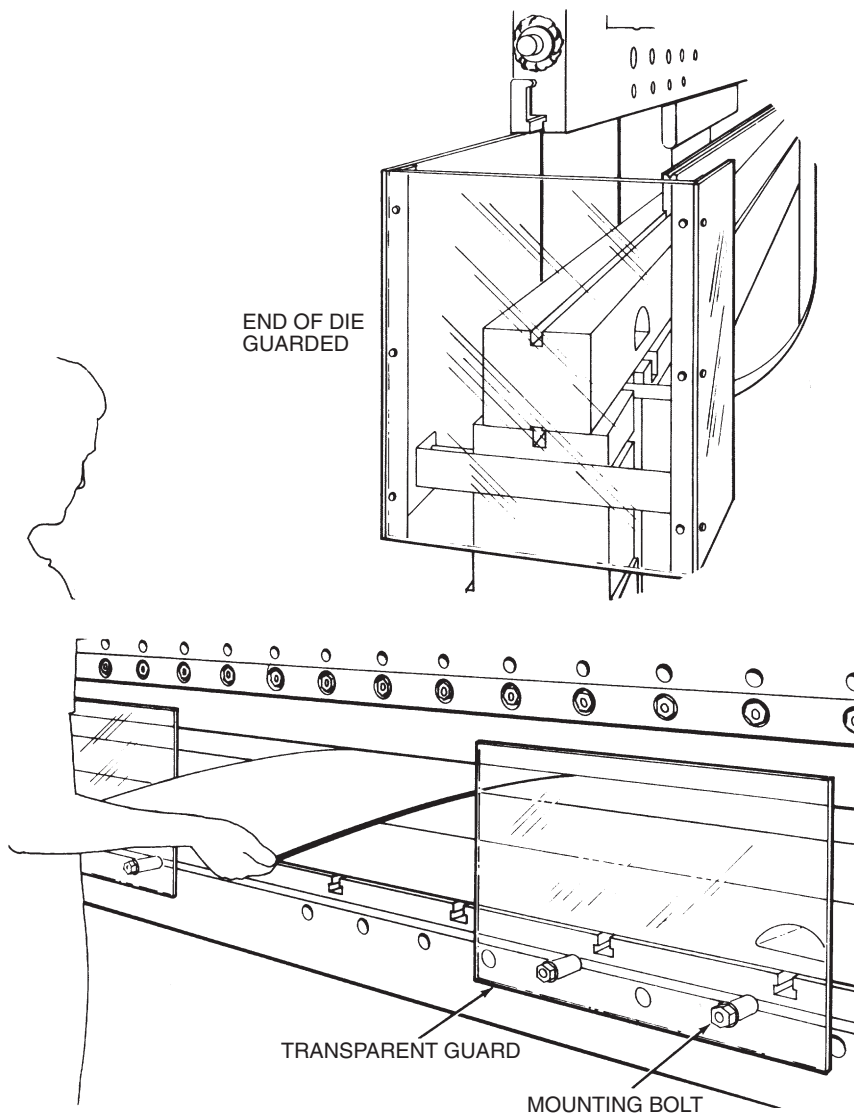

A fixed guard is shown on a veneer clipper in Figure 16. This guard acts as a barrier, protecting fingers from exposure to the blade. Note the side view of the curved portion of the guard.

Figure 16

Fixed Guard on Veneer Clipper

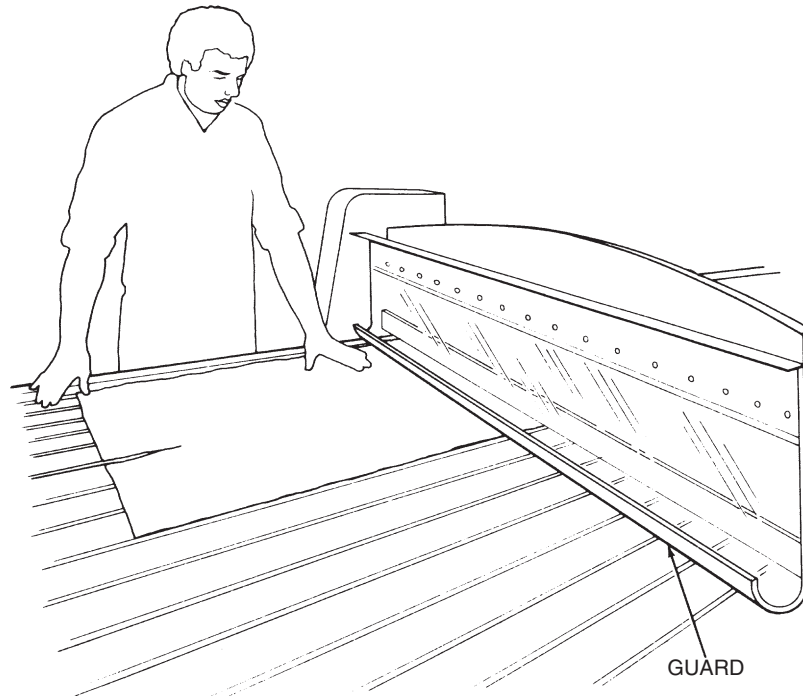
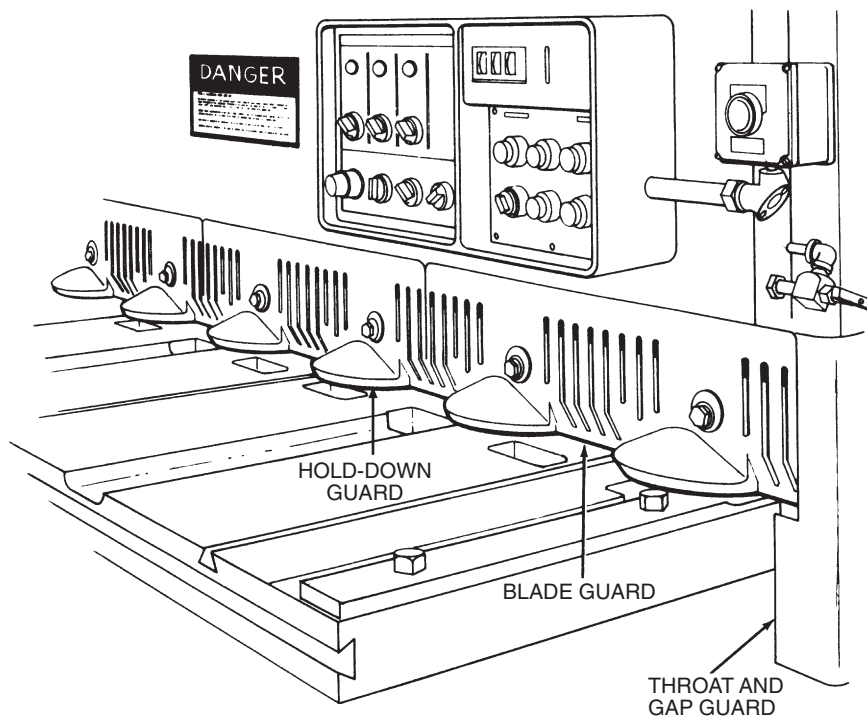

Figure 17 shows both a fixed blade guard and a throat and gap guard on a power squaring shear. These guards should be removed only for maintenance or blade changes. Hold-down devices, arranged along the bed near the blade, engage the stock and clamp it firmly in position for shearing. The hold-downs must be properly guarded to prevent fingers and hands from entering the danger area.

Figure 17

Fixed Guard on a Power Squaring Shear



Interlocked Guards

When the interlocked guard is opened or removed, the tripping mechanism and/or power automatically shuts off or disengages, and the machine cannot cycle or be started until the guard is back in place.

An interlocked guard may use electrical, mechanical, hydraulic or pneumatic power or any combination of these. Interlocks should not prevent “inching” by remote control, if required. Replacing the guard should not automatically restart the machine.

Figure 18 shows an interlocked barrier guard mounted on an automatic bread bagging machine. When the guard is removed, the machine will not function.

Figure 18

Interlocked Guard on Automatic Bread Bagging Machine

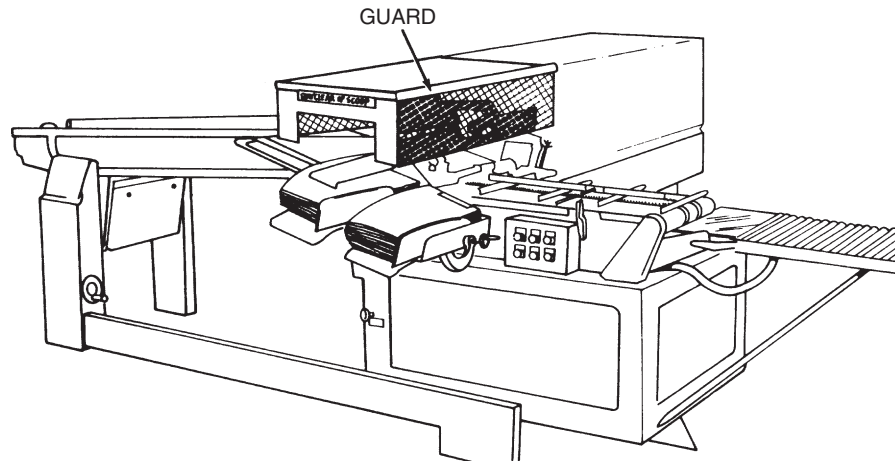

In Figure 19, the beater mechanism of a picker machine (used in the textile industry) is covered by an interlocked barrier guard. This guard cannot be raised while the machine is running, nor can the machine be restarted with the guard in the raised position.

Figure 19

Interlocked Guard on Picker Machine

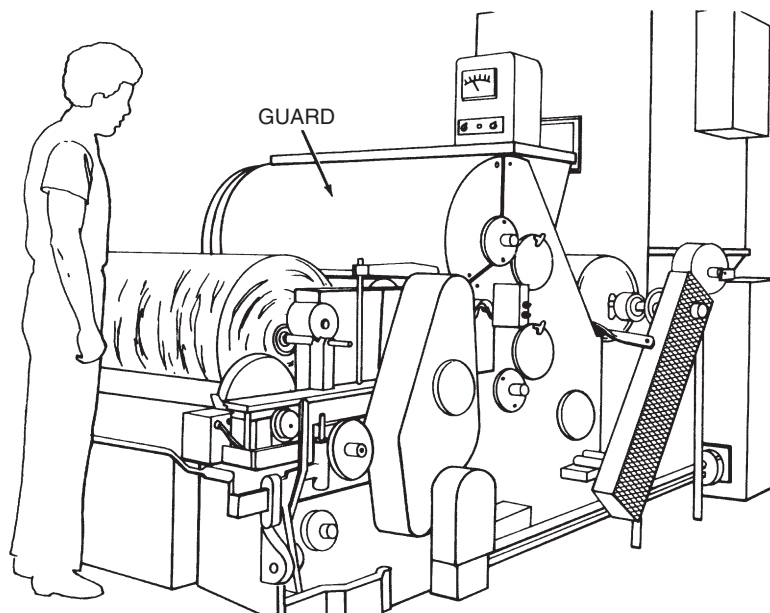

In Figure 20, an interlocked guard covers the rotating cylinder of the dividing head of a roll make-up machine used for making hamburger and hot dog rolls.

Figure 20

Interlocked Guard on Roll Make-up Machine

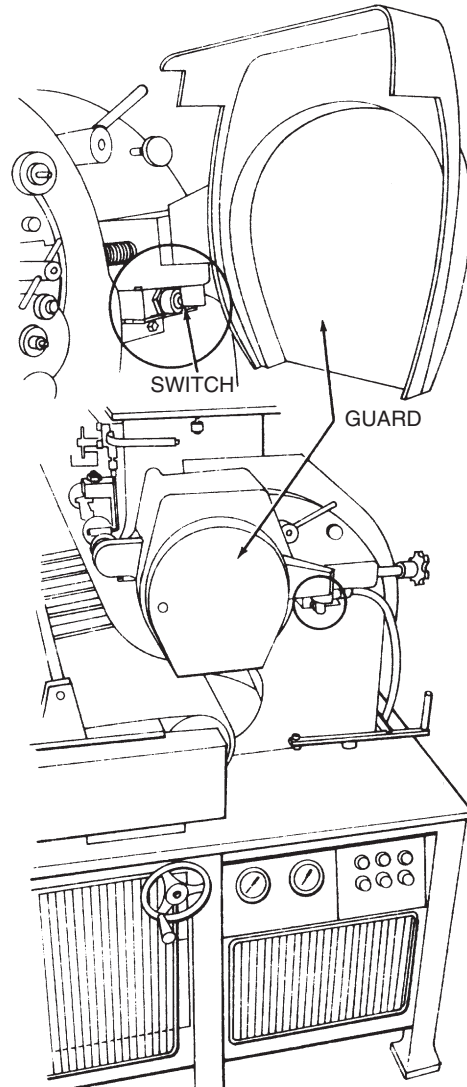
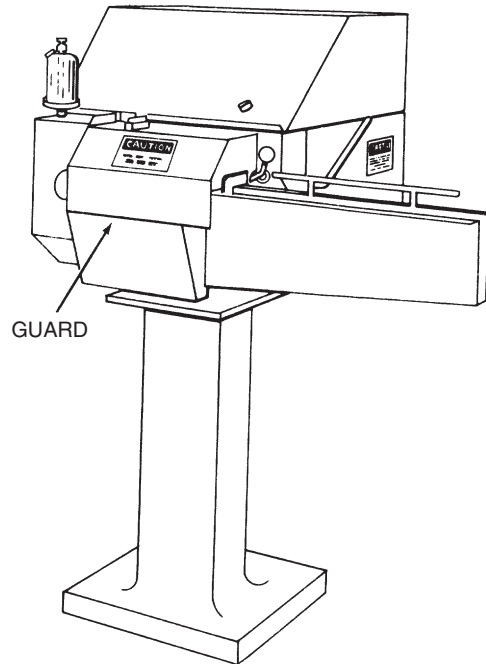

Figure 21 shows a corn cutter with an interlocked panel that acts as a barrier guard, preventing the operator from putting his or her hands into the fast-turning cutter blades as the corn is being stripped from the cob. If the guard is opened or removed while the machine is running, the power disengages and a braking mechanism stops the blades before a hand can reach into the danger area.

Figure 21

Interlocked Guard on Corn Cutter



Adjustable Guards

Adjustable guards are usable because they allow flexibility in accommodating various sizes of stock. Figure 22 shows an adjustable guard on a shaper, which can be adjusted according to the thickness of the stock.

Figure 22

Adjustable Guard on a Shaper

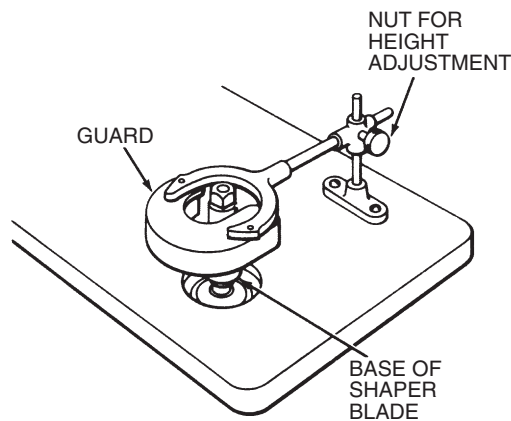

In Figure 23, the bars adjust to accommodate the size and shape of the stock for the power press.

Figure 23

Adjustable Guard on a Power Press

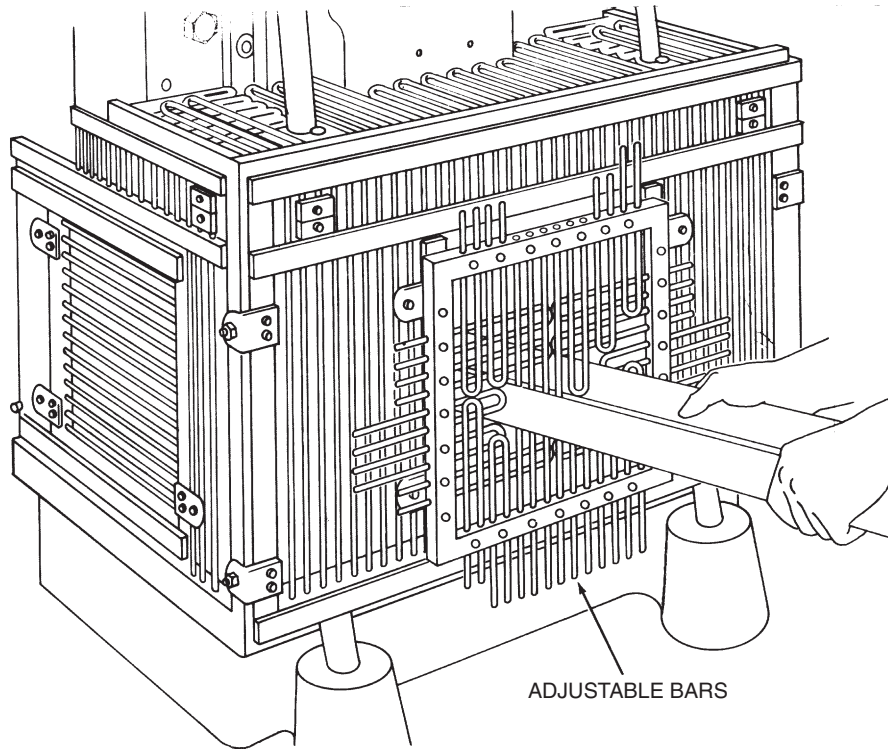

Figure 24 shows an adjustable guard on a router, which adjusts to the thickness of the stock.

Figure 24

Adjustable Guard on a Router

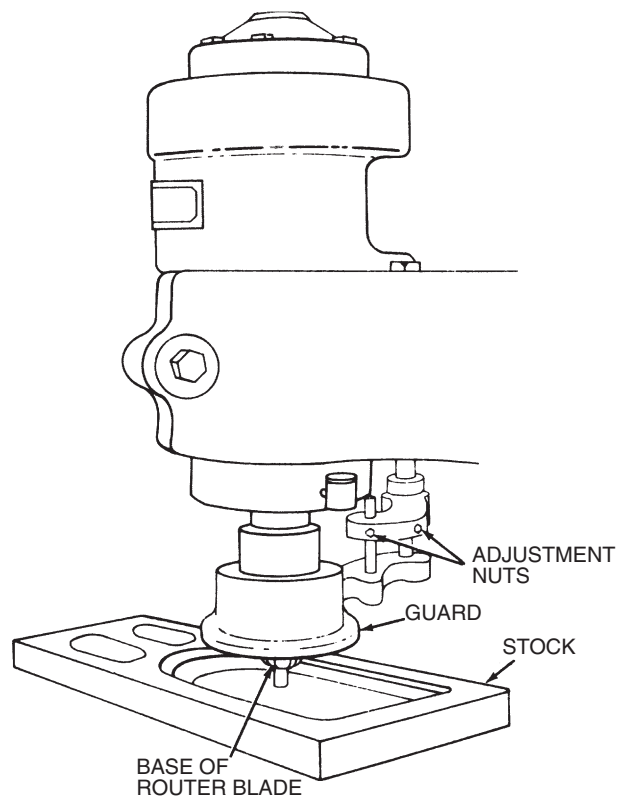
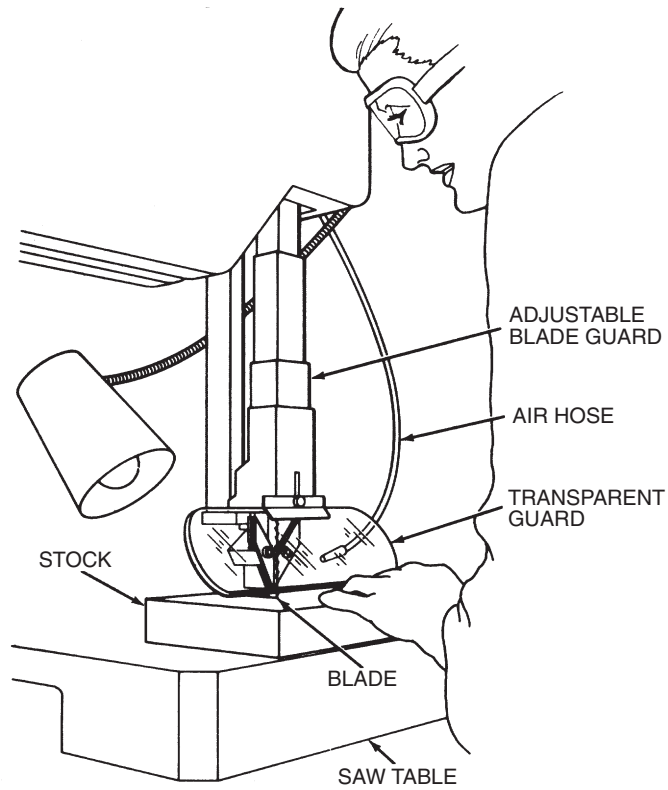

Figure 25 shows an adjustable enclosure guard on a band saw.

Figure 25

Adjustable Guard on a Band Saw



In Figure 26, the guard adjusts to provide a barrier between the operator and the blade.

Figure 26

Adjustable Guard on a Table Saw

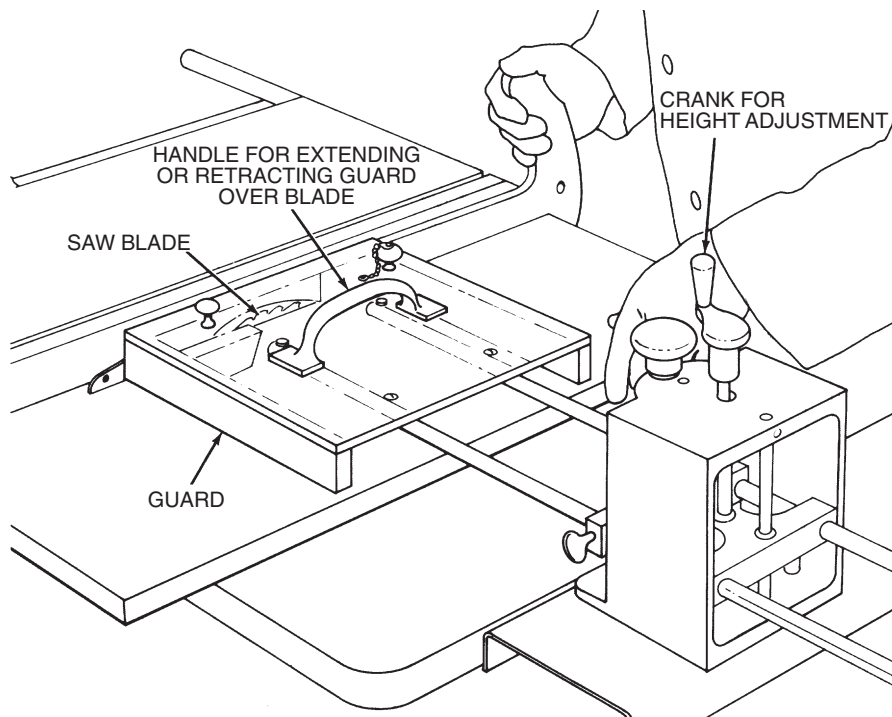
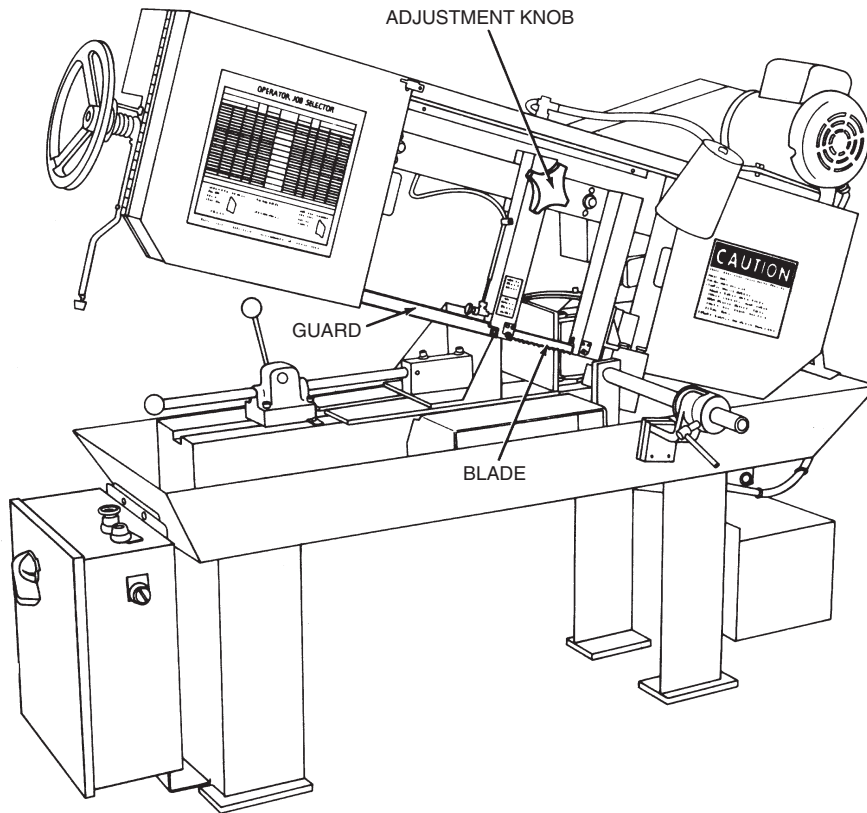

Figure 27 shows a band saw with an adjustable guard to protect the operator from the unused portion of the blade. This guard can be adjusted according to the size of stock.

Figure 27

Adjustable Guard on a Horizontal Band Saw



Self-Adjusting Guards

The openings of these barriers are determined by the movement of the stock. As the operator moves the stock into the danger area, the guard is pushed away, providing an opening that is only large enough to admit the stock. After the stock is removed, the guard returns to the rest position. This guard protects the operator by placing a barrier between the danger area and the operator. The guards may be constructed of plastic, metal or other substantial material. Self-adjusting guards offer different degrees of protection.

Figure 28 shows a radial arm saw with a self-adjusting guard. As the blade is pulled across the stock, the guard moves up, staying in contact with the stock.

Figure 28

Self-adjusting Guard on Radial Arm Saw

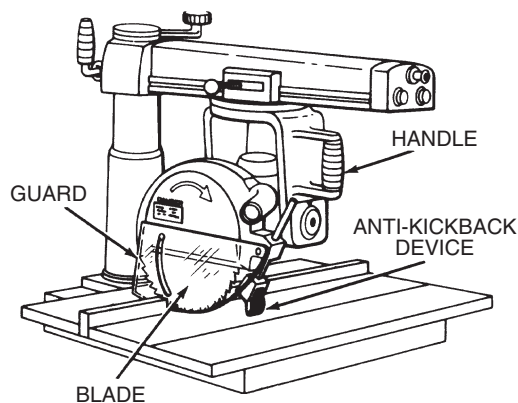
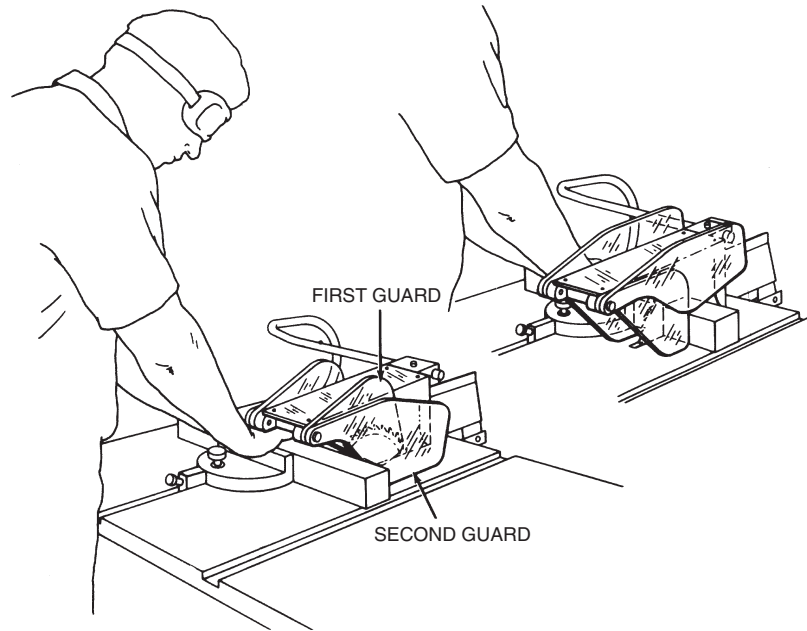

Figure 29 shows a twin-action, transparent, self-adjusting guard. The first guard rises as the stock enters, then returns to its rest position as the stock moves ahead to raise the second guard.

Figure 29

Self-adjusting Guard on a Table Saw



A self-adjusting guard is shown in Figure 30. As the blade moves through the stock, the guard rises up to the stock surface.

Figure 30

Self-adjusting Guard on a Circular Saw

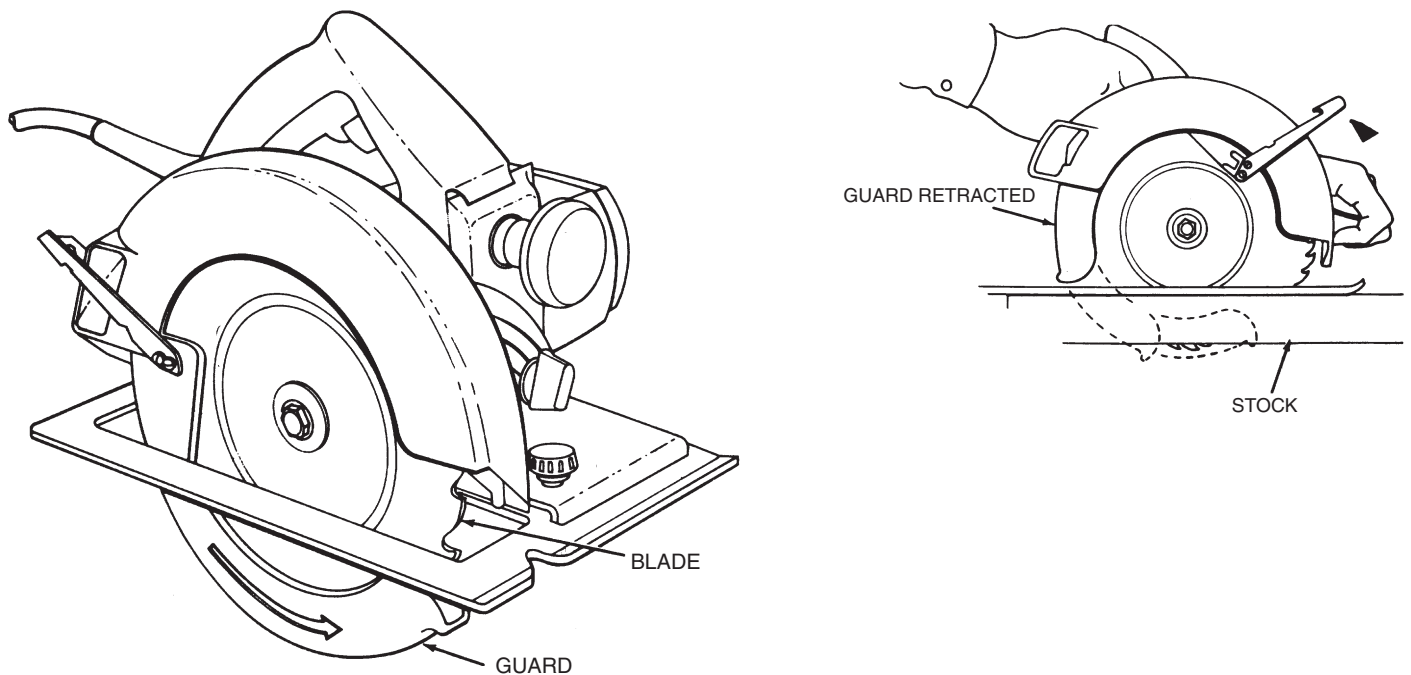
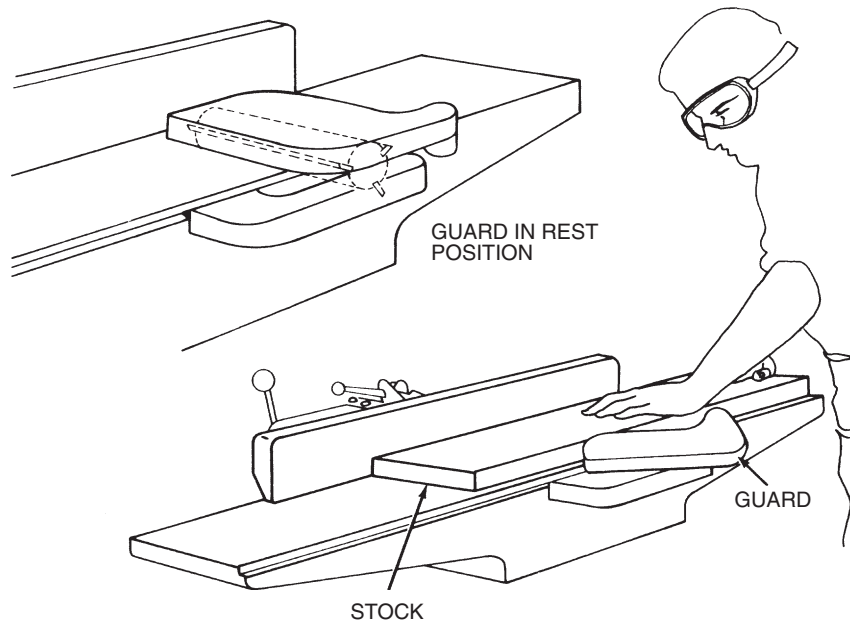

Figure 31 shows a self-adjusting enclosure guard mounted on a jointer. This guard is moved from the cutting head by the stock. After the stock is removed, the guard will return, under spring tension, to the rest position.

Figure 31

Self-adjusting Guard on a Jointer



Another type of self-adjusting guard mounted on a jointer is illustrated in Figure 32. The guard moves two ways. An edging operation causes the guard to move horizontally. If the stock is wide enough during a surfacing operation, the stock may be fed under the guard, causing it to move vertically.

Figure 32

Self-adjusting Guard on a Jointer

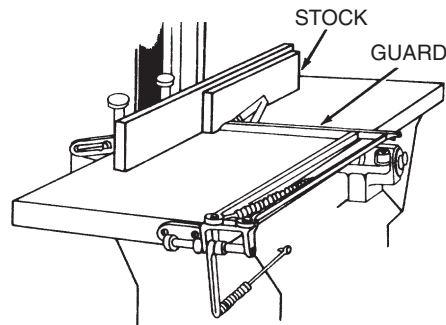

<i>(Method)</i>	Guards <i>(Safeguarding action)</i>	Advantages	Limitations
Fixed	Provides a barrier.	Can be constructed to suit many specific applications. In-plant construction is often possible. Can provide maximum protection. Usually requires minimum maintenance. Can be suitable to high production, repetitive operations	May interfere with visibility. Can be limited to specific operations. Machine adjustment and repair often require its removal, thereby necessitating other means of protection for maintenance personnel.
Interlocked	Shuts off or disengages power and prevents starting of machine when guard is open; should require the machine to be stopped before the worker can reach into the danger area.	Can provide maximum protection. Allows access to machine for removing jams without time-consuming removal of fixed guards.	Requires careful adjustment and maintenance. May be easy to disengage.
Adjustable	Provides a barrier that may be adjusted to facilitate a variety of production operations.	Can be constructed to suit many specific applications. Can be adjusted to admit varying sizes of stock	Hands may enter danger area—protection may not be complete at all times. May require frequent maintenance and/or adjustment. The guard may be made ineffective by the operator. May interfere with visibility.
Self-adjusting	Provides a barrier that moves according to the size of the stock entering.	Off-the-shelf guards are often commercially available.	Does not always provide maximum protection. May interfere with visibility. May require frequent maintenance and adjustment.

Devices

A safety device may perform one of several functions. It may stop the machine if a hand or any part of the body is inadvertently placed in the danger area; restrain or withdraw the operator's hands from the danger area during operation; require the operator to use both hands on machine controls, thus keeping both hands and body out of danger; or provide a barrier that is synchronized with the operating cycle of the machine in order to prevent entry to the danger area during the hazardous part of the cycle.

Presence-Sensing Devices

Photoelectric (optical)

The photoelectric (optical) presence-sensing device uses a system of light sources and controls that can interrupt the machine's operating cycle. If the light field is broken, the machine stops and will not cycle. This device must be used only on machines that can be stopped before the worker can reach the danger area. The device requires frequent maintenance, cleaning and alignment.

Figure 33 shows a photoelectric presence-sensing device on a part-revolution power press. When the light beam is broken, either the ram will not start to cycle, or, if the press is already functioning, the stopping mechanism will be activated.

Figure 33

Photoelectric Presence-Sensing Device on Power Press

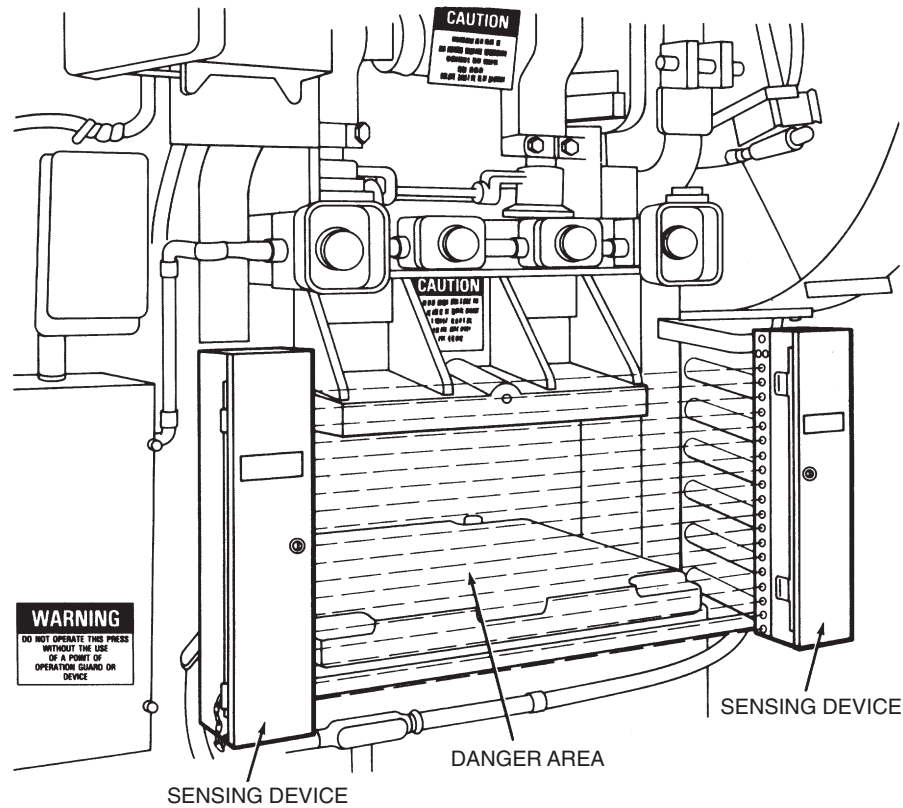

A photoelectric presence-sensing device used with a press brake is illustrated in Figure 34. The device may be swung up or down to accommodate different production requirements.

Figure 34

Photoelectric Presence-Sensing Device on Press Brake

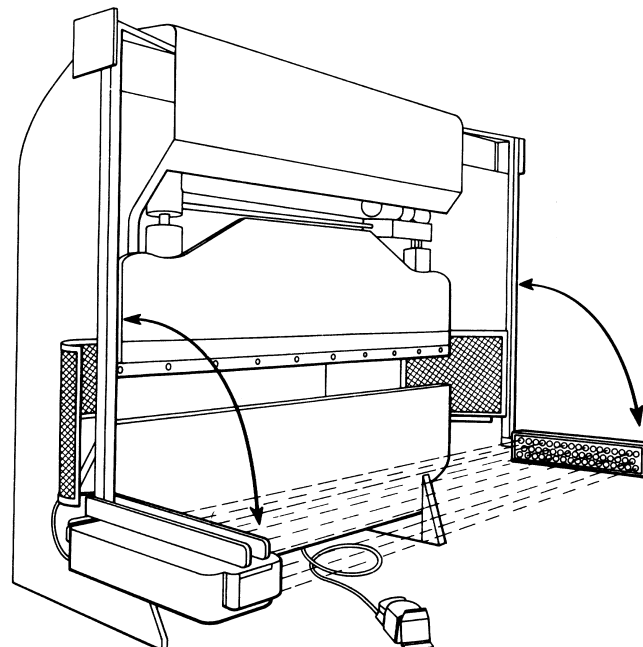

Radiofrequency (capacitance)

The radiofrequency (capacitance) presence-sensing device uses a radio beam that is part of the machine control circuit. When the capacitance field is broken, the machine will stop or will not activate. Like the photoelectric device, this device must only be used on machines that can be stopped before the worker can reach the danger area. This requires the machine to have a friction clutch or other reliable means for stopping.

Figure 35 shows a radiofrequency presence-sensing device mounted on a part-revolution power press.

Figure 35

Radiofrequency Presence-Sensing Device on a Power Press

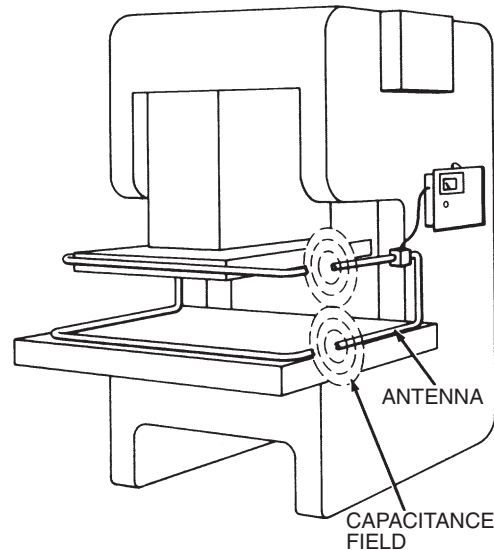

Electromechanical

The electromechanical sensing device has a probe or contact bar that descends to a predetermined distance when the operator initiates the machine cycle. If there is an obstruction preventing it from descending its full predetermined distance, the control circuit does not actuate the machine cycle.

Figure 36 shows an electromechanical sensing device on an eyeletter. The sensing probe in contact with the operator's finger is also shown.

Figure 36

Electromechanical Sensing Device on an Eyeletter

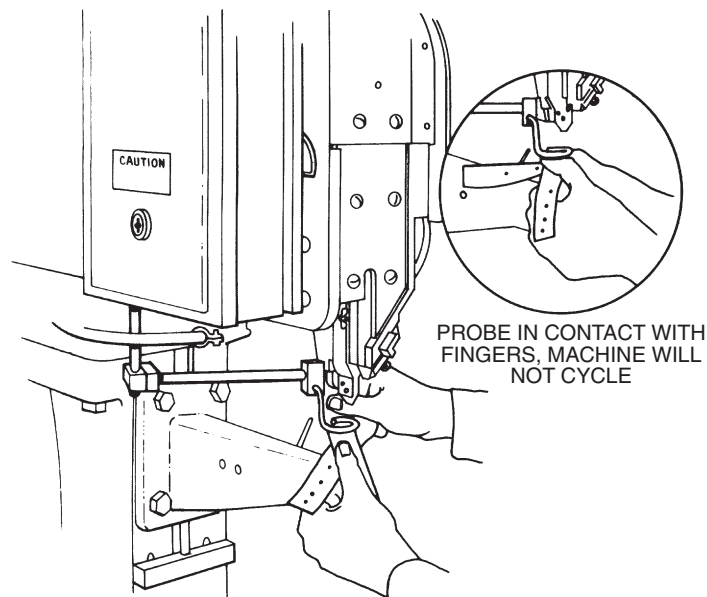

Pullback Devices

Pullback devices utilize a series of cables attached to the operator's hands, wrists and/or arms. This type of device is primarily used on machines with stroking action. When the slide/ram is up, the operator is allowed access to the point of operation. When the slide/ram begins to descend, a mechanical linkage automatically ensures withdrawal of the hands from the point of operation.

Figure 37 shows a pullback device on a straight-side power press. When the slide/ram is in the "up" position, the operator can feed material by hand into the point of operation. When the press cycle is actuated, the operator's hands and arms are automatically withdrawn. The pullback device must be carefully adjusted to fit each operator.

Figure 37

Pullback Device on a Power Press

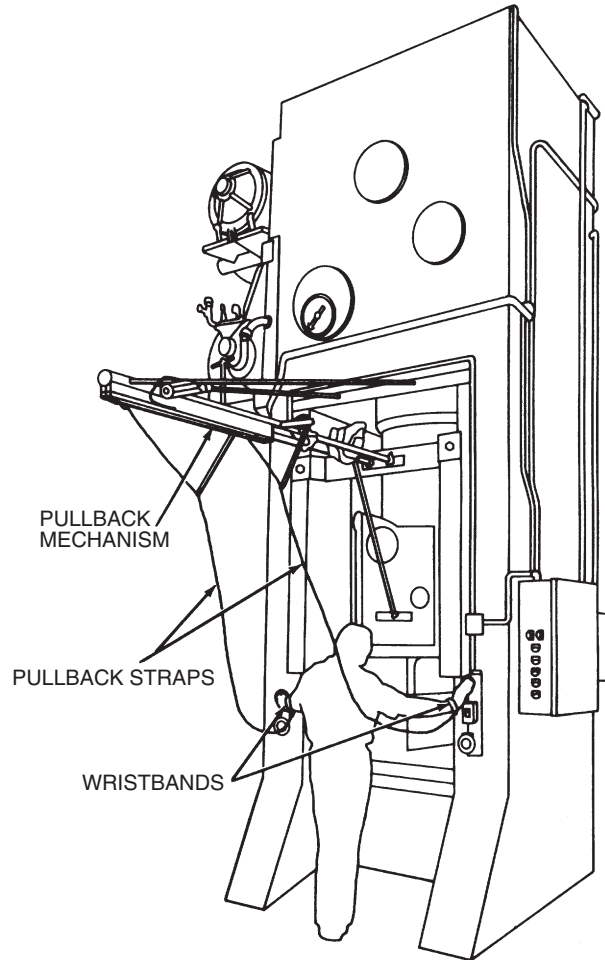
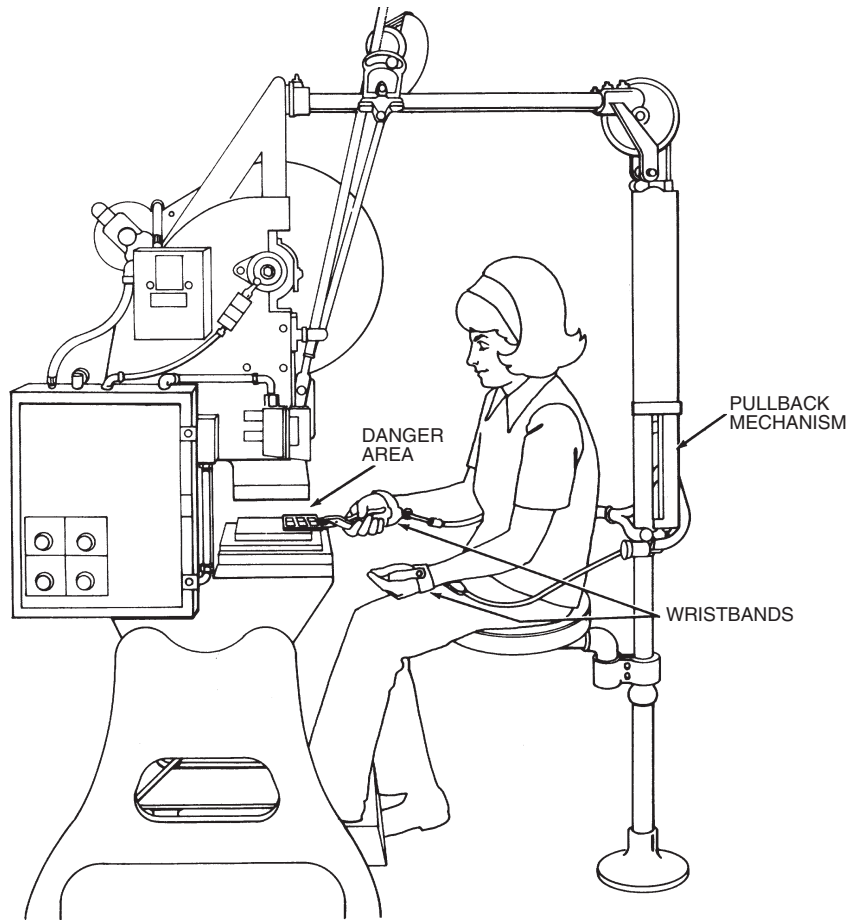

Figure 38 shows a pullback device on a small press.

Figure 38

Pullback Device on a Power Press



Restraint Devices

The restraint (holdout) device in Figure 39 utilizes cables or straps that are attached to the operator's hands and to a fixed point. The cables or straps must be adjusted to let the operator's hands travel within a predetermined safe area. Consequently, hand-feeding tools are often necessary if the operation involves placing material into the danger area. The restraint device must be carefully adjusted to fit each operator.

Figure 39

Restraint Device on a Power Press

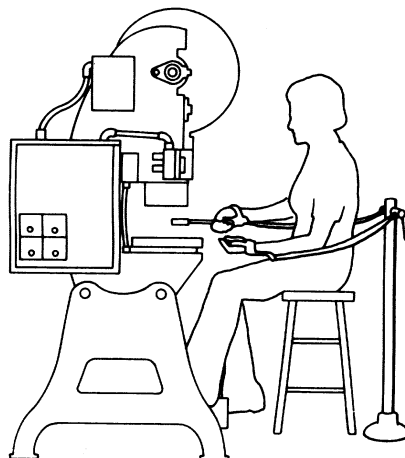

Safety Control Devices

Safety Trip Controls

Safety trip controls provide a quick means for deactivating the machine in an emergency situation.

Pressure-Sensitive Body Bar: A pressure-sensitive body bar, when depressed, will deactivate the machine. If the operator or anyone trips, loses balance, or is drawn into the machine, applying pressure to the bar will stop the operation. The positioning of the bar, therefore, is critical. Figure 40 shows a pressure-sensitive body bar located on the front of a rubber mill.

Figure 40

Pressure-Sensitive Body Bar on a Rubber Mill

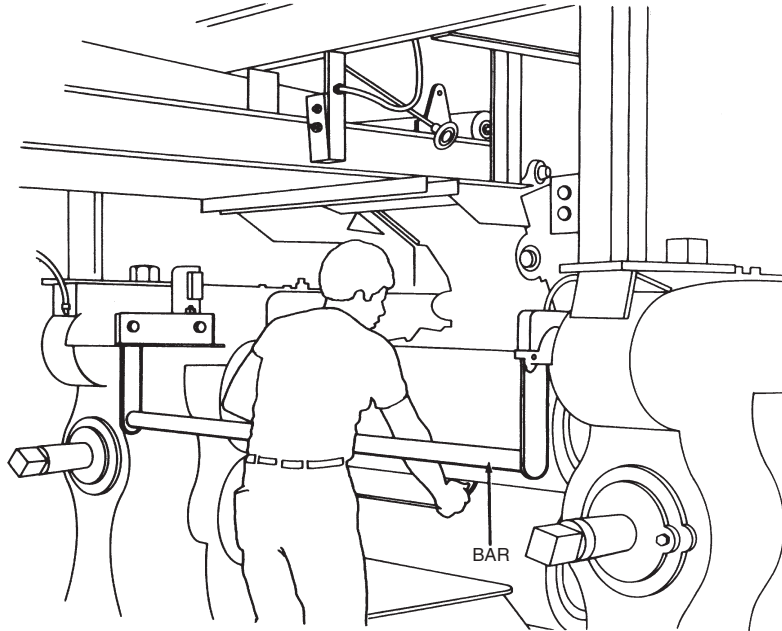

Safety Tripod: When pressed by hand, the safety tripod deactivates the machine. Because it has to be actuated by the operator during an emergency situation, its proper position is also critical. Figure 41 shows a tripod located above the rubber mill.

Figure 41

Safety Tripod on a Rubber Mill

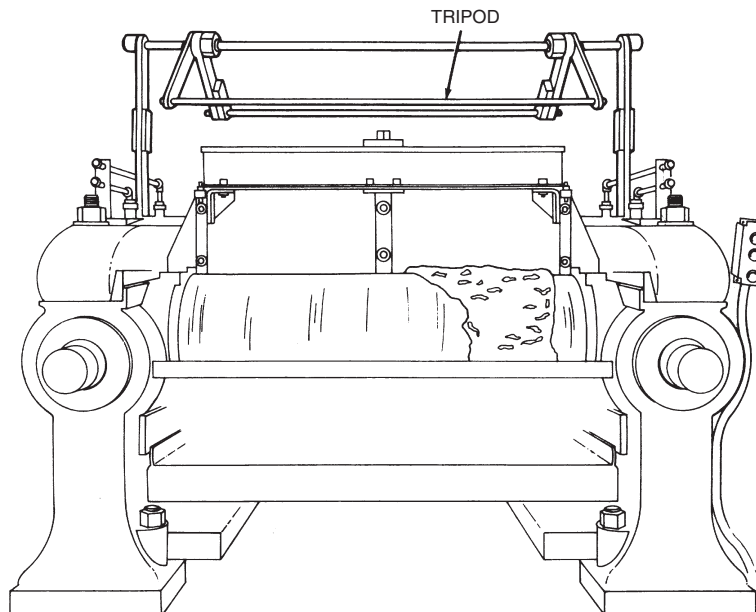
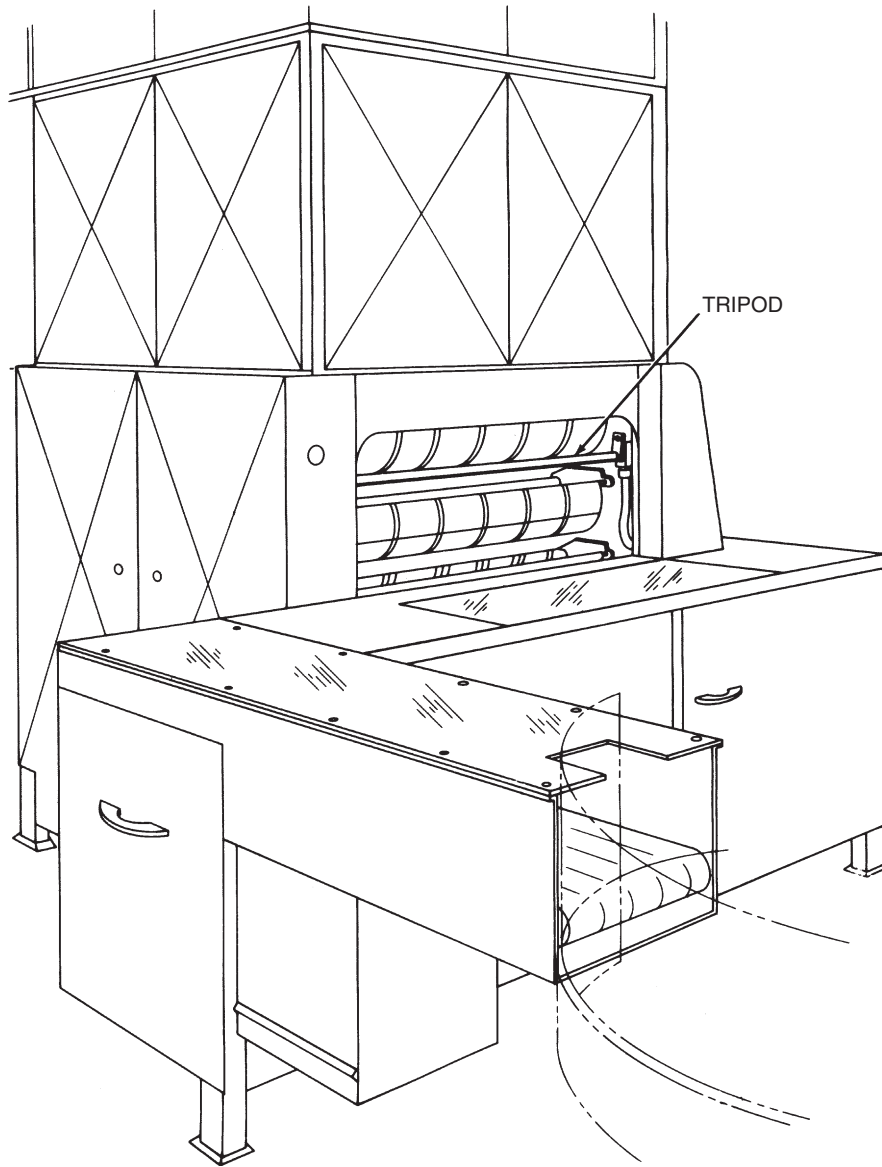

Figure 42 shows another application of a tripod.

Figure 42

Safety Tripod on a Bread Proofer Machine



Safety Tripwire Cable: Safety tripwire cables are located around the perimeter of or near the danger area. The operator must be able to reach the cable with either hand to stop the machine. Figure 43 shows a calender equipped with this type of control.

Figure 43
Safety Tripwire Cable on a Calender

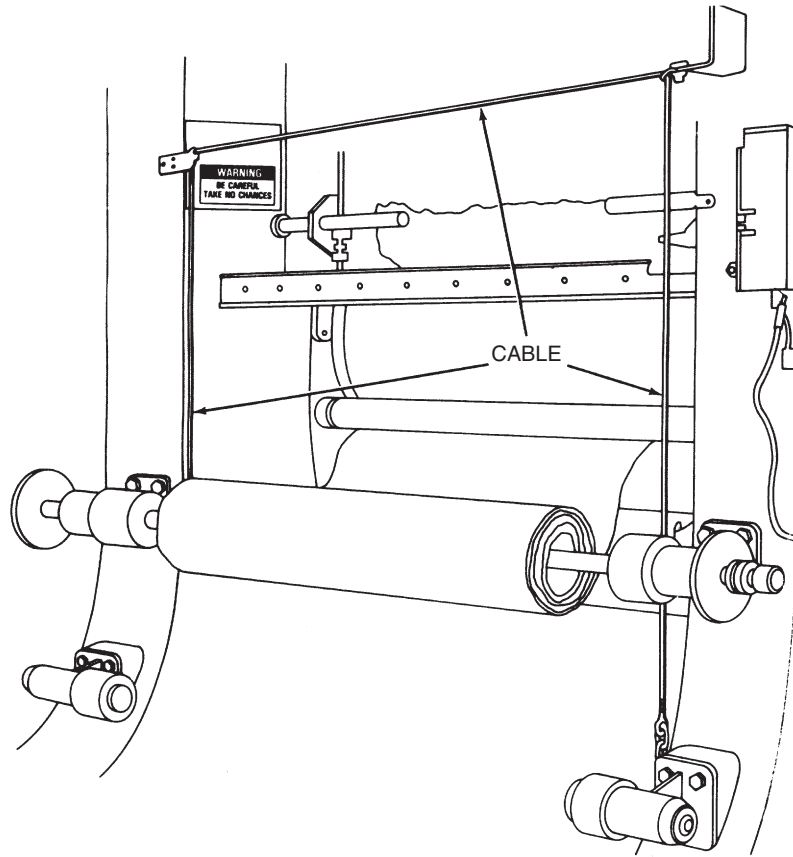
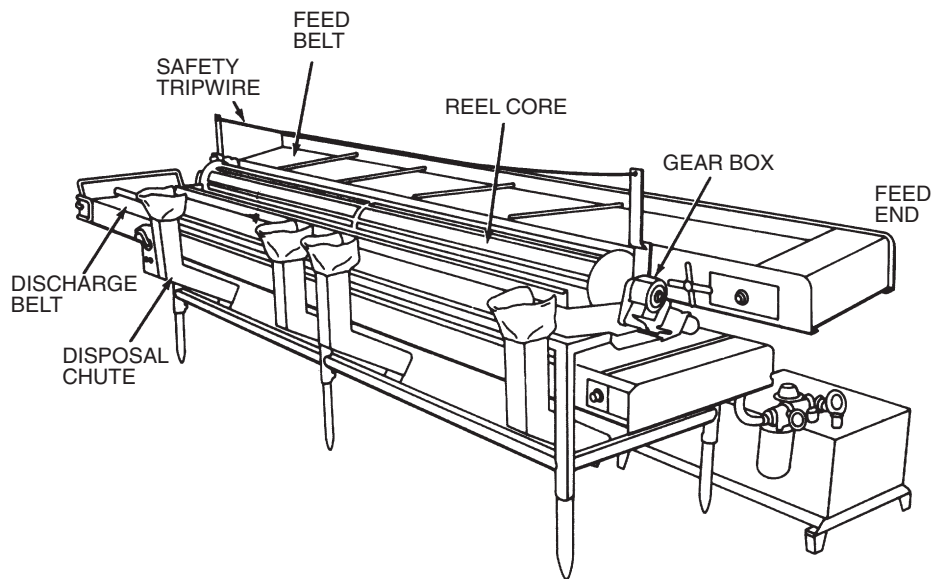

Figure 44 shows a tomato sorter with a safety tripwire cable.

Figure 44
Safety Tripwire on a Tomato Sorter



Two-hand Control

The two-hand control requires constant, concurrent pressure by the operator to activate the machine. This kind of control requires a part-revolution clutch, brake and a brake monitor if used on a power press as shown in Figure 45. With this type of device, the operator's hands are required to be at a safe location (on control buttons) and at a safe distance from the danger area while the machine completes its closing cycle.

Figure 45

Two-hand Control Buttons on a Part-revolution Clutch Power Press

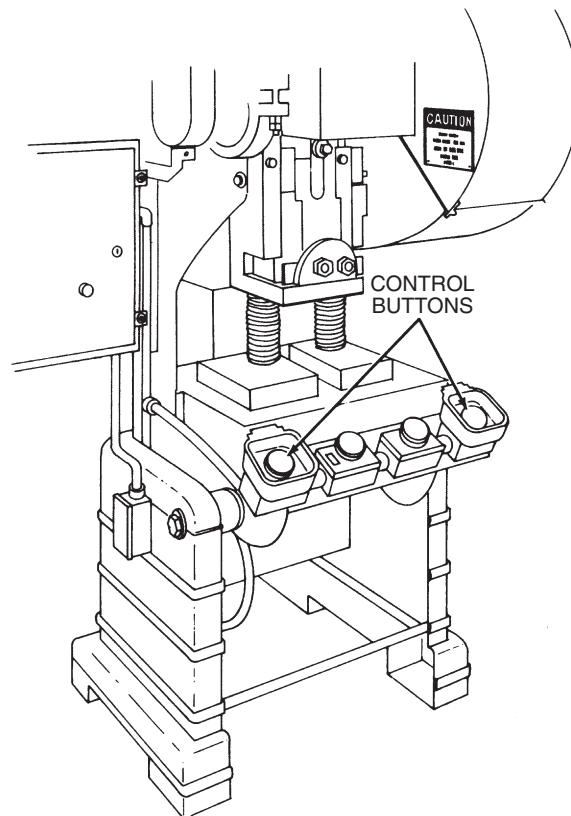

Two-hand Trip

The two-hand trip in Figure 46 requires concurrent application of both of the operator's control buttons to activate the machine cycle, after which the hands are free. This device is usually used with machines equipped with full-revolution clutches. The trips must be placed far enough from the point of operation to make it impossible for the operator to move his or her hands from the trip buttons or handles into the point of operation before the first half of the cycle is completed. Thus, the operator's hands are kept far enough away to prevent them from being accidentally placed in the danger area prior to the slide/ram or blade reaching the full "down" position.

Figure 46

Two-hand Trip Buttons on a Full-revolution Clutch Power Press

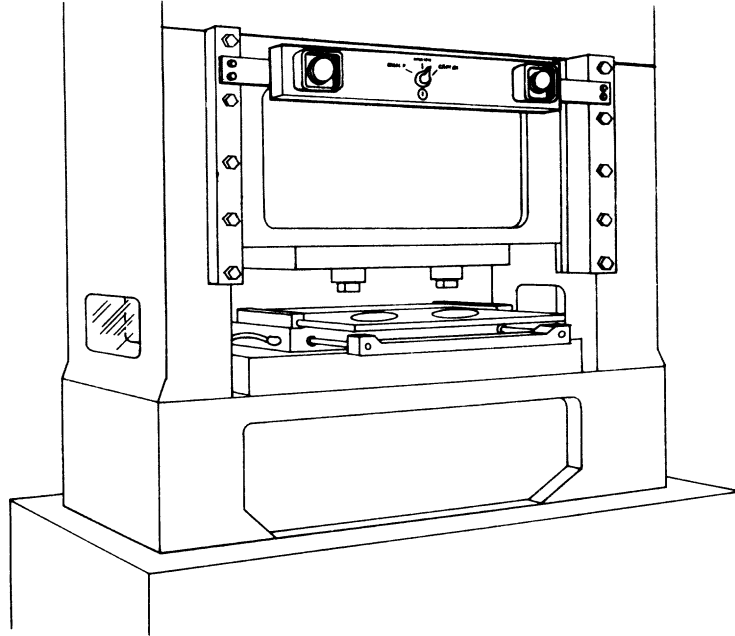

Gates

A gate is a movable barrier that protects the operator at the point of operation before the machine cycle can be started. Gates are, in many instances, designed to be operated with each machine cycle.

Figure 47 shows a horizontal injection molding machine with a gate. It must be in the closed positions before the machine can function.

Figure 47

Horizontal Injection Molding Machine With Gate

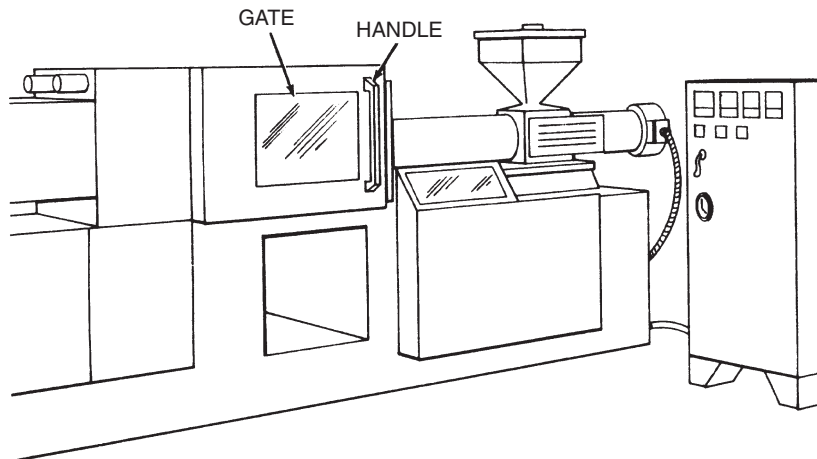
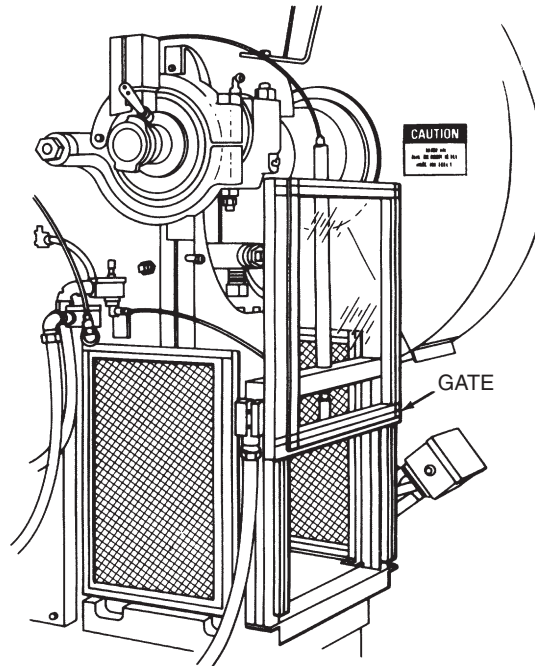

Figure 48 shows a gate on a power press. If the gate is not permitted to descend to the fully closed position, the press will not function.

Figure 48
Power Press With Gate



Another potential application of this type of guard is where the gate is a component of a perimeter safeguarding system. There, the gate may provide protection not only to the operator but to pedestrian traffic as well.

	Devices	Advantages	Limitations
<i>(Method)</i>	<i>(Safeguarding action)</i>		
Photoelectric (optical)	Machine will not start cycling when the light field is broken by any part of the operator's body during cycling process, immediate machine braking is activated.	Can allow freer movement for operator.	Does not protect against mechanical failure. May require frequent alignment and calibration. Excessive vibration may cause lamp filament damage and premature burnout. Limited to machines that can be stopped.
Radio frequency (capacitance)	Machine cycling will not start when the capacitance field is interrupted. When the capacitance field is disturbed by any part of the operator's body during the cycling process, immediate machine braking is activated.	Can allow freer movement for operator.	Does not protect against mechanical failure. Antennae sensitivity must be properly adjusted. Limited to machines that can be stopped.

<i>(Method)</i>	Devices <i>(Safeguarding action)</i>	Advantages	Limitations
Electromechanical	Contact bar or probe travels a predetermined distance between the operator and the danger area. Interruption of this movement prevents the starting of machine cycle.	Can allow access at the point of operation.	Contact bar or probe must be properly adjusted for each application; this adjustment must be maintained properly.
Pullback	As the machine begins to cycle, the operator's hands are pulled out of the danger area.	Eliminates the need for auxiliary barriers or other interference at the danger area.	Limits movement of operator. May obstruct workspace around operator. Adjustments must be made for specific operations and for each individual. Requires frequent inspections and regular maintenance. Requires close supervision of the operator's use of the equipment.
Restraint (holdback)	Prevents the operator from reaching into the danger area.	Little risk of mechanical failure.	Limits movements of operator. May obstruct workspace. Adjustments must be made for specific operations and each individual. Requires close supervision of the operator's use of the equipment.
Safety trip controls: Pressure sensitive body bar; Safety triprod; Safety trip-wire	Stops machine when tripped.	Simplicity of use.	All controls must be manually activated. May be difficult to activate controls because of their location. Only protects the operator. May require special fixtures to hold work. May require a machine brake.
Two-hand control	Concurrent use of both hands is required, preventing the operator from entering the danger area.	Operator's hands are at a predetermined location. Operator's hands are free to pick up a new part after first half of cycle is completed.	Requires a partial cycle machine with a brake. Some two-hand controls can be rendered unsafe by holding with arm or blocking, thereby permitting one-hand operation. Protects only the operator.

	Devices	Advantages	Limitations
<i>(Method)</i>	<i>(Safeguarding action)</i>		
Two-hand trip	Concurrent use of two hands on separate controls prevents hands from being in danger area when machine cycle starts.	Operator's hands are kept away from danger area. Can be adapted to multiple operations. No obstructions to hand feeding. Does not require adjustment for each operation.	Operator may try to reach into danger area after tripping machine. Some trips can be rendered unsafe by holding with arm or blocking, thereby permitting one-hand operation. Protects only the operator. May require special features.
Gate	Provides a barrier between danger area and operator or other personnel.	Can prevent reaching into or walking into the danger area.	May require frequent inspection and regular maintenance. May interfere with operator's ability to see the work.

Safeguarding by Location/Distance

The examples mentioned below are a few of the numerous applications of the principle of safeguarding by location/distance. A thorough hazard analysis of each machine and particular situation is absolutely essential before attempting this safeguarding technique.

To safeguard a machine by location, the machine or its dangerous moving parts must be so positioned that hazardous areas are not accessible or do not present a hazard to a worker during the normal operation of the machine. This may be accomplished by locating a machine so that a plant design feature, such as a wall, protects the worker and other personnel. Additionally, enclosure walls or fences can restrict access to machines. Another possible solution is to have dangerous parts located high enough to be out of the normal reach of any worker.

The feeding process can be safeguarded by location if a safe distance can be maintained to protect the worker's hands. The dimensions of the stock being worked on may provide adequate safety. For instance, if the stock is several feet long and only one end of the stock is being worked on, the operator may be able to hold the opposite end while the work is being performed. An example would be a single-end punching machine. However depending upon the machine, protection might still be required for other personnel.

The positioning of the operator's control station provides another potential approach to safeguarding by location. Operator controls may be located at a safe distance from the machine if there is no reason for the operator to tend it.

In Figure 49, the food grinder to the left shows a hopper of such size and a neck so small that the operator's fingers cannot come in contact with the worm. The food grinder to the right illustrates a distance from the front of the hopper to the opening over the worm, which is such that the operator cannot reach into the worm.

Figure 49

Food Grinders—Guarding by Position

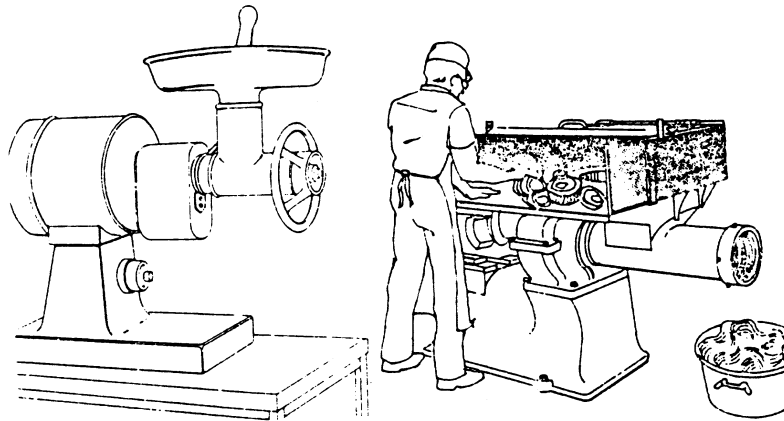

Feeding and Ejection Methods to Improve Operator Safety

Many feeding and ejection methods do not require the operator to place his or her hands in the danger area. In some cases, no operator involvement is necessary after the machine is set up. In other situations, operators can manually feed the stock with the assistance of a feeding mechanism. Properly designed ejection methods do not require any operator involvement after the machine starts to function.

Some feeding and ejection methods may even create hazards themselves. For instance, a robot may eliminate the need for an operator to be near the machine but may create a new hazard itself by the movement of its arm.

Using these feeding and ejection methods does not eliminate the need for guards and devices. Guards and devices must be used wherever they are necessary and possible to provide protection from exposure to hazards.

Automatic Feeds

Automatic feeds reduce the exposure of the operator during the work process, and sometimes do not require any effort by the operator after the machine is set up and running.

In Figure 50, the power press has an automatic feeding mechanism. Notice the transparent fixed enclosure guard at the danger area.

Figure 50

Power Press With Automatic Feed

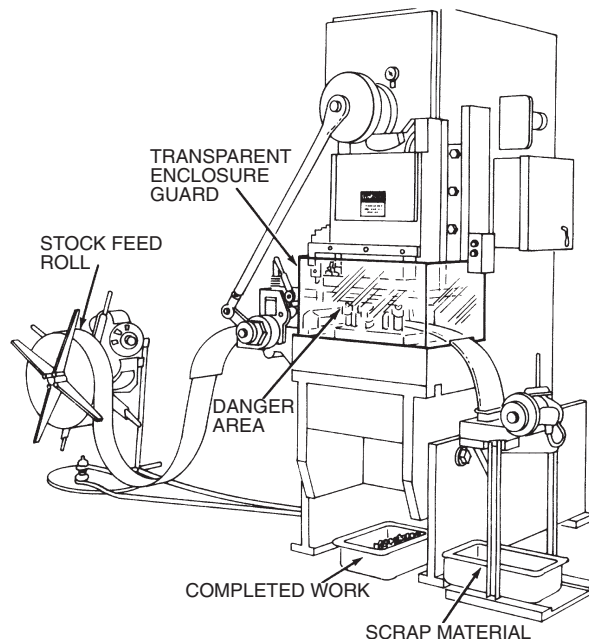
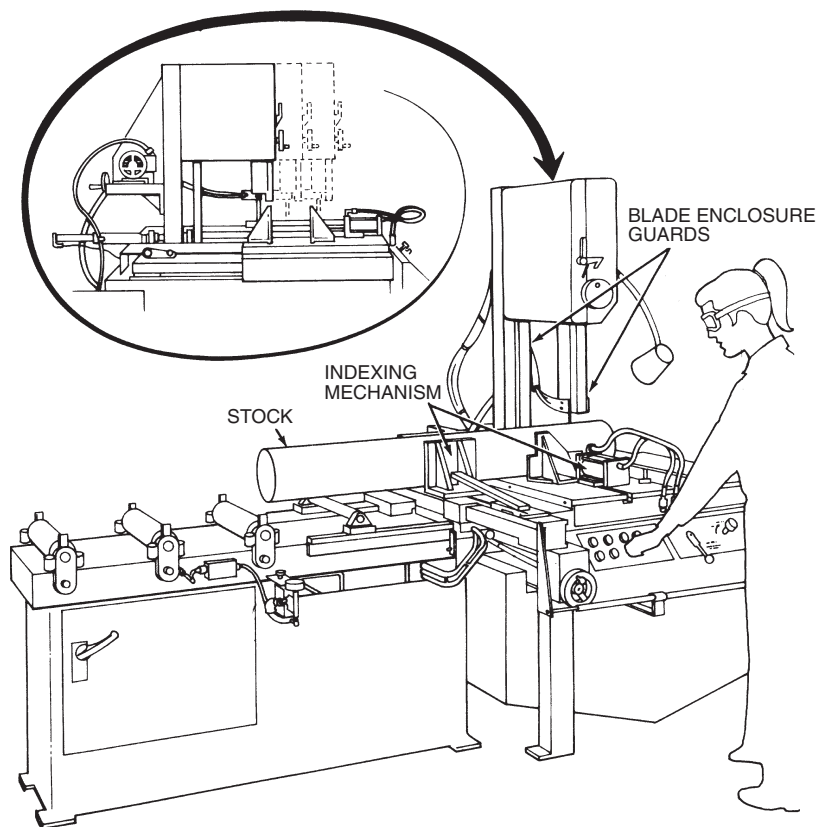

Figure 51 shows a saw with an automatic indexing mechanism that moves the stock a predetermined distance for each cut. The traveling head automatically recycles for each cut.

Figure 51

Saw With Automatic Indexing Mechanism and Traveling Head



Semiautomatic Feeding

With semiautomatic feeding, as in the case of a power press, the operator uses a mechanism to place the piece being processed under the ram at each stroke. The operator does not need to reach into the danger area, and the danger area is completely enclosed.

Figure 52 shows a chute feed. It may be either a horizontal or an inclined chute into which each piece is placed by hand. Using a chute feed on an inclined press not only helps center the piece as it slides into the die, but may also simplify the problem of ejection.

Figure 52

Power Press With Chute Feed

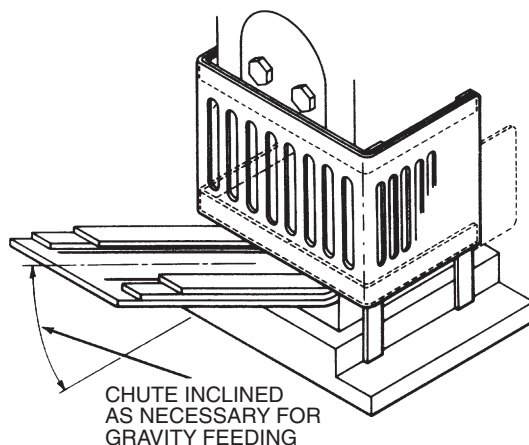

A plunger feed is shown in Figure 53. The blanks or pieces are placed in the nest one at a time by the plunger that pushes them under the slide. Plunger feeds are useful for operations on irregularly shaped workpieces that will not stack in a magazine or will not slide easily down a gravity chute. The mechanism shown is mechanically connected to the press tripping mechanism. When the plunger is pushed in, pin “B” is allowed to rise up into hole “A,” allowing yoke “C” to release so the press can be tripped.

Figure 53

Power Press With Plunger Feed

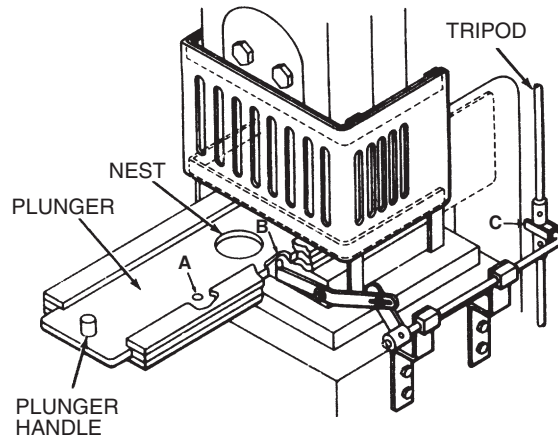

Figure 54 shows a plunger and magazine feed. Slot “A” must be in alignment with interlock “B” before the press can be tripped.

Figure 54

Power Press With Plunger and Magazine Feed

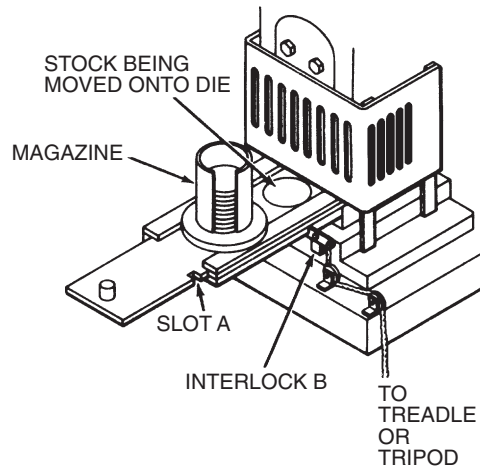
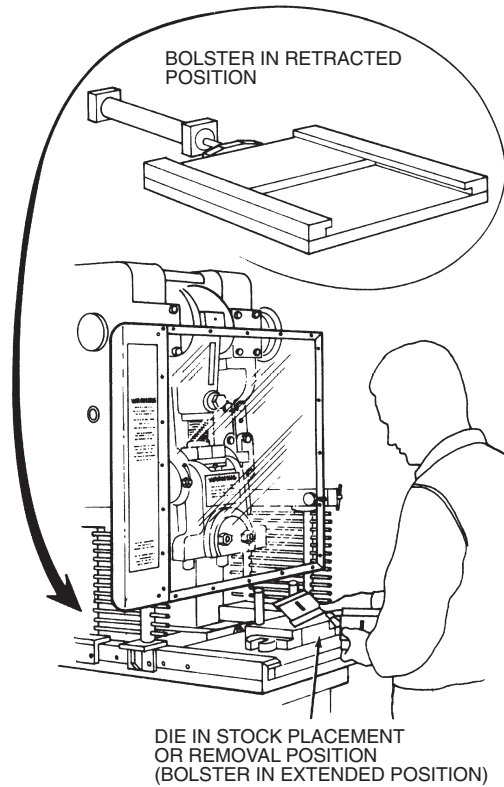

Figure 55 shows a sliding bolster. The press bed is modified with a hydraulically or pneumatically controlled bolster that slides in when “start” buttons are depressed, and out when the stroke is completed.

Figure 55

Power Press With Sliding Bolster



The sliding die in Figure 56 is pulled toward the operator for safe feeding and then pushed into position under the slide prior to the downward stroke. The die moves in and out by hand or by a foot lever. The die should be interlocked with the press to prevent tripping when the die is out of alignment with the slide. Providing “stops” will prevent the die from being inadvertently pulled out of the slides.

Figure 56

Power Press With Sliding Die

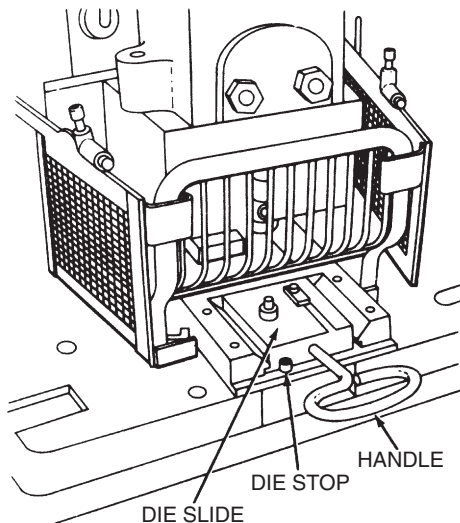
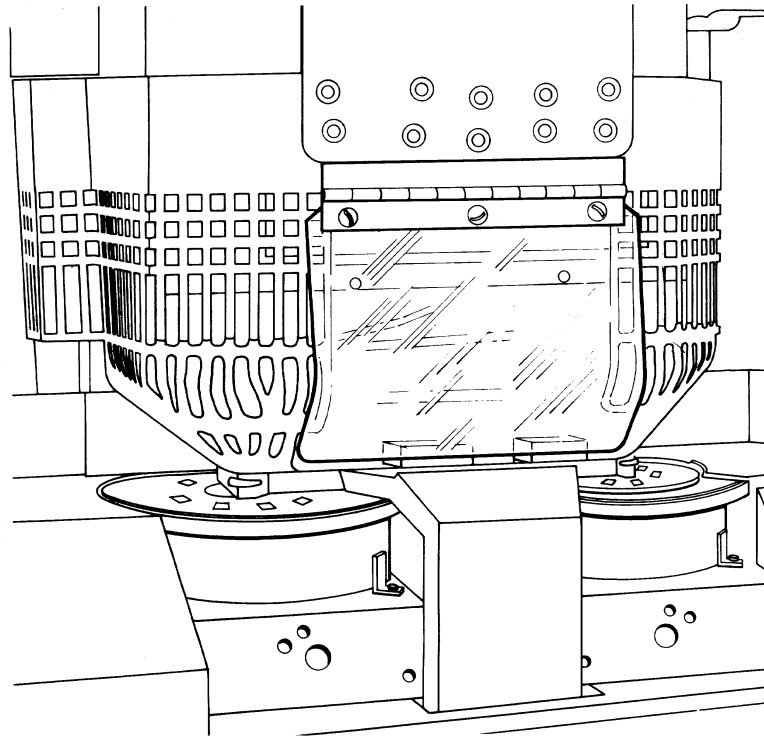

Figure 57 shows a double-dial feed.

Figure 57

Power Press With Double-dial Feed



On the machine in Figure 57, the dials revolve with each stroke of the press. The operator places the part to be processed in a nest on the dial that is positioned in front of the die. The dial is indexed with each upstroke of the press to deliver the nested part into the die.

Automatic Ejection

Automatic ejection may employ either an air-pressure or a mechanical apparatus to remove the completed part from a press. It may be interlocked with the operating controls to prevent operation until part ejection is accomplished. This method requires additional safeguards for full protection of the operator.

As shown in Figure 58, the pan shuttle mechanism moves under the finished part as the slide moves toward the “up” position. The shuttle then catches the part stripped from the slide by the knockout pins and deflects it into a chute. When the ram moves down toward the next blank, the pan shuttle moves away from the die area.

Figure 58

Shuttle Ejection Mechanism

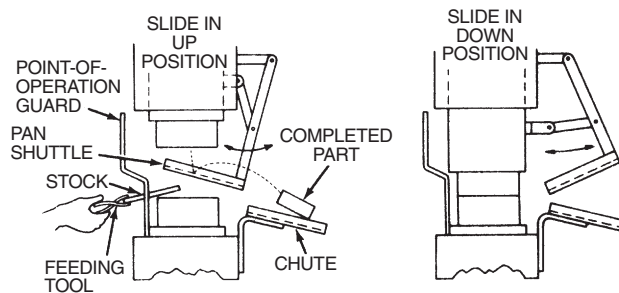

Figure 59 shows an air ejection mechanism. Note: Air ejection methods often present a noise hazard to operators.

Figure 60 shows a mechanical ejection mechanism.

Figure 59

Air Ejection

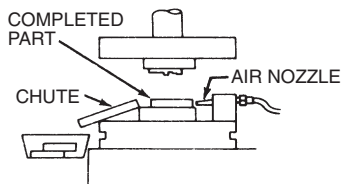
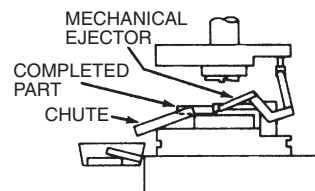

Figure 60

Mechanical Ejection



Semiautomatic Ejection

Figure 61 shows a semiautomatic ejection mechanism used on a power press. When the plunger is withdrawn from the die area the ejector leg, which is mechanically coupled to the plunger, kicks the completed work out.

Figure 61

Semiautomatic Ejection Mechanism

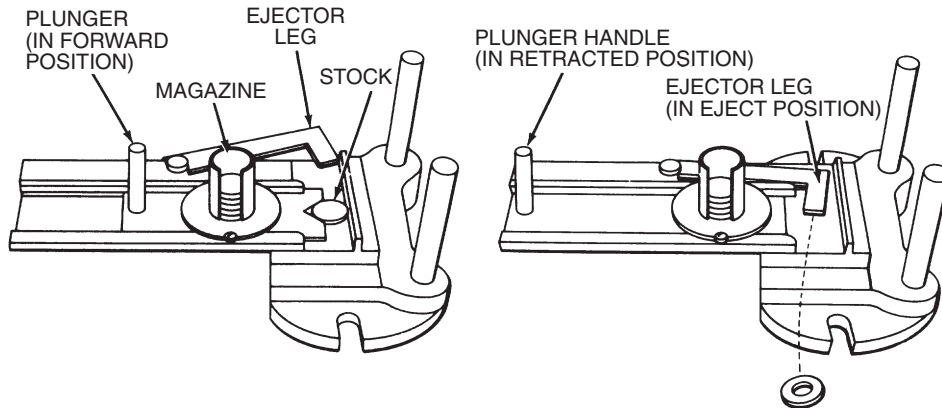

Robots

Robots are machines that load and unload stock, assemble parts, transfer objects, or perform other complex or repetitive tasks, without the assistance or intervention of an operator. Robots may create hazards themselves, and, if they do, appropriate guards must be used. Initial set-up routines, to establish repetitive actions for robotic machines, require special precautions and special training for set-up employees. This is so because set-up routines may preclude the use of normal barrier guards.

Figure 62 shows a type of robot in operation.

Figure 62

Robot Movement Capability

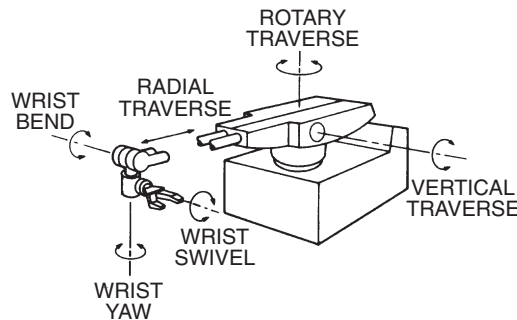
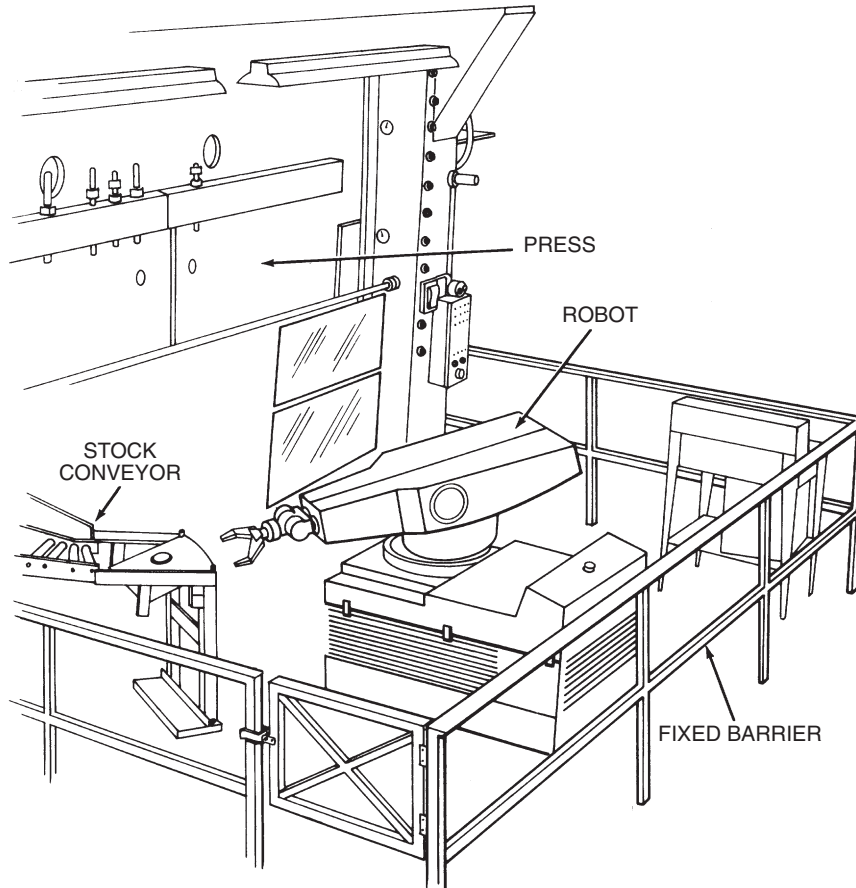

Figure 63 provides an example of the kind of task (feeding a press) that a robot can perform.

Figure 63

A Robot, Feeding a Press



Feeding and Ejection Methods		Advantages	Limitations
<i>(Method)</i>	<i>(Safeguarding action)</i>		
Automatic feed	Stock is fed from rolls, indexed by machine mechanism.	Eliminates the need for operator involvement in the danger area.	Additional guards are required for operator protection—usually fixed barrier guards. Requires frequent maintenance. May not be adaptable to stock variation.
Semiautomatic feed	Stock is fed by chutes, movable dies, dial feed, plungers or sliding bolster.	In some cases, no operator involvement is necessary after the machine is set up.	Does not eliminate the need for guards and devices where exposed to hazards.
Automatic ejection	Work pieces are ejected by air or mechanical means.	Does not require any operator involvement after the machine starts to function.	May create a hazard of blowing chips or debris. Size of stock limits the use of this method. Air ejection may present a noise hazard.
Semiautomatic ejection	Workpieces are ejected by mechanical means that are initiated by the operator.	Operator does not have to enter danger area to remove finished work.	Other guards are required for operator protection. May not be adaptable to stock variation.
Robots	They perform work usually done by operator.	Operator does not have to enter danger area. Are suitable for operations where high stress factors are present, such as heat and noise.	Can create hazards themselves. Require maximum maintenance. Are suitable only to specific operations.

Types and Classification of Robots

Industrial robots are programmable multifunctional mechanical devices designed to move material, parts, tools or specialized devices through variable programmed motions to perform a variety of tasks. An industrial robot system includes not only industrial robots but also any devices and/or sensors required for the robot to perform its tasks as well as sequencing or monitoring communication interfaces.

Robots are generally used to perform unsafe, hazardous, highly repetitive and unpleasant tasks. They have many different functions such as material handling, assembly, arc welding, resistance welding, machine tool load and unload functions, painting, and spraying. Most robots are set up for an operation by the teach-and-repeat technique. In this mode, a trained operator (programmer) typically uses a portable control device (a teach pendant) to teach a robot its task manually. Robot speeds during these programming sessions are slow.

Industrial robots are available commercially in a wide range of sizes, shapes, and configurations. They are designed and fabricated with different design configurations and a different number of axes or degrees of freedom. These factors of a robot's design influence its working envelope (the volume of working or reaching space). Diagrams of the different robot design configurations are shown next in Figure 64.

Figure 64

Robot Arm Design Configurations

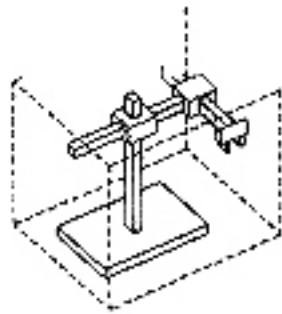

RECTANGULAR COORDINATE ROBOT

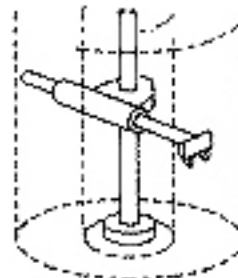

CYLINDRICAL COORDINATE ROBOT

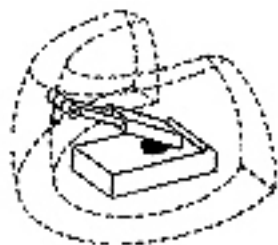

SPHERICAL COORDINATE ROBOT

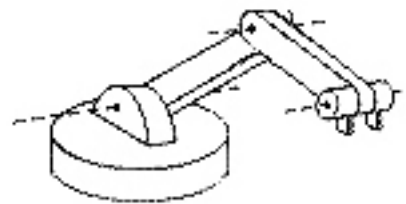

ARTICULATED ARM ROBOT

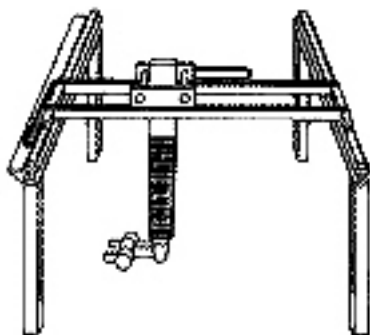

GANTRY ROBOT

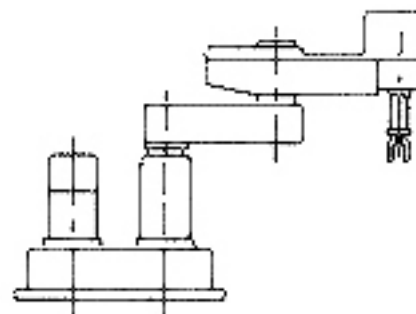

SCARA ROBOT

Servo and Nonservo. All industrial robots are either servo or nonservo controlled. Servo robots are controlled through the use of sensors that continually monitor the robot's axes and associated components for position and velocity. This feedback is compared to pretaught information that has been programmed and stored in the robot's memory. Nonservo robots do not have the feedback capability, and their axes are controlled through a system of mechanical stops and limit switches.

Type of Path Generated. Industrial robots can be programmed from a distance to perform their required and preprogrammed operations with different types of paths generated through different control techniques. The three different types of paths generated are point-to-point path, controlled path and continuous path.

1. **Point-to-Point Path.** Robots programmed and controlled in this manner are programmed to move from one discrete point to another within the robot's working envelope. In the automatic mode of operation, the exact path taken by the robot will vary slightly due to variations in velocity, joint geometries and point spatial locations. This difference in paths is difficult to predict and therefore can create a potential safety hazard to personnel and equipment.
2. **Controlled Path.** The path or mode of movement ensures that the end of the robot's arm will follow a predictable (controlled) path and orientation as the robot travels from point to point. The coordinate transformations required for this hardware management are calculated by the robot's control system computer. Observations that result from this type of programming are less likely to present a hazard to personnel and equipment.
3. **Continuous Path.** A robot whose path is controlled by storing a large number or close succession of spatial points in memory during a teaching sequence is a continuous path controlled robot. During this time, and while the robot is being moved, the coordinate points in space of each axis are continually monitored on a fixed time base, e.g., 60 or more times per second, and placed into the control system's computer memory. When the robot is placed in the automatic mode of operation, the program is replayed from memory and a duplicate path is generated.

Robot Components. Industrial robots have four major components: the mechanical unit, power source, control system, and tooling (Figure 65).

Mechanical Unit. The robot's manipulative arm is the mechanical unit. This mechanical unit is also composed of a fabricated structural frame with provisions for supporting mechanical linkage and joints, guides, actuators (linear or rotary), control valves, and sensors. The physical dimensions, design and weight-carrying ability depend on application requirements.

Figure 65

Industrial Robots: Major Components

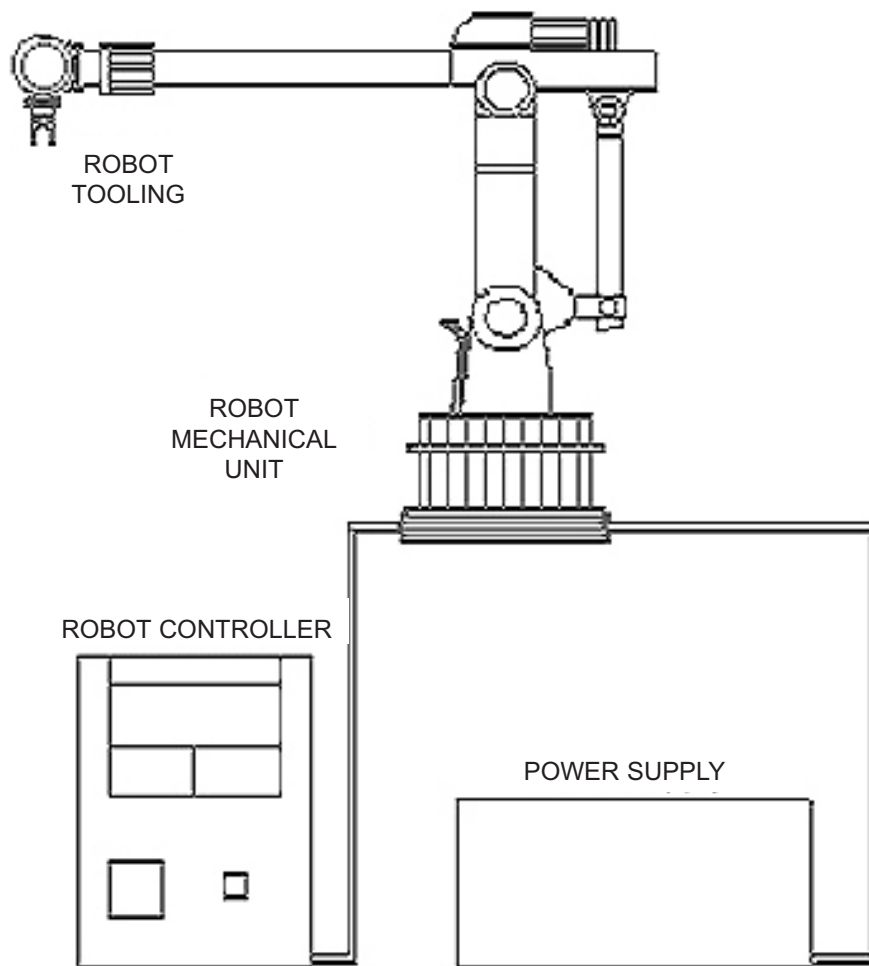

Power Sources

1. Energy is provided to various robot actuators and their controllers as pneumatic, hydraulic or electrical power. The robot's drives are usually mechanical combinations powered by these types of energy, and the selection is usually based upon application requirements. For example, pneumatic power (low-pressure air) is used generally for low weight carrying robots.
2. Hydraulic power transmission (high-pressure oil) is usually used for medium to high force or weight applications, or where smoother motion control can be achieved than with pneumatics. Consideration should be given to potential hazards of fires from leaks if petroleum-based oils are used.
3. Electrically powered robots are the most prevalent in industry. Either AC or DC electrical power is used to supply energy to electromechanical motor-driven actuating mechanisms and their respective control systems. Motion control is much better, and in an emergency an electrically powered robot can be stopped or powered down more safely and faster than those with either pneumatic or hydraulic power.

Robot Safeguarding

The proper selection of an effective robotic safeguarding system should be based upon a hazard analysis of the robot system's use, programming and maintenance operations. Among the factors to be considered are the tasks a robot will be programmed to perform, start-up and command or programming procedures, environmental conditions, location and installation requirements, possible human errors, scheduled and unscheduled maintenance, possible robot and system malfunctions, normal mode of operation, and all personnel functions and duties.

An effective safeguarding system protects not only operators but also engineers, programmers, maintenance personnel, and any others who work on or with robot systems and could be exposed to hazards associated with a robot's operation. A combination of safeguarding methods may be used. Redundancy and backup systems are especially recommended, particularly if a robot or robot system is operating in hazardous conditions or handling hazardous materials. The safeguarding devices employed should not themselves constitute or act as a hazard or curtail necessary vision or viewing by attending human operators.

Definitions

- Maximum space is the volume of space encompassing the maximum-designed movements of all robot parts, including the end-effector, workpiece and attachments.
- Operating space is that portion of the restricted space actually used by the robot while performing its task program.
- Restricted space is that portion of the maximum space to which a robot is restricted by limiting devices. See Figure 66.

Figure 66

Maximum, Restricted and Operating Space

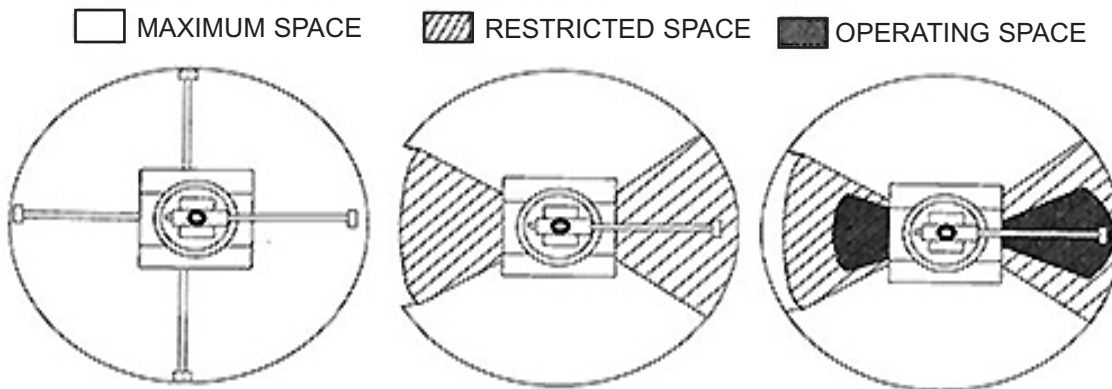

Robot Teach and Verification

Clearance (slow speed)

- 18–20 inch clearance in operating space from areas of building, structures, utilities, other machines and equipment that may create trapping or a pinch point

Note: If clearance is not provided, additional safeguarding is required

Safeguarded space is the space defined by the perimeter safeguarding devices.

Goal:

- Prevent access to the hazard-barrier fencing.
- Install safety devices at other sections that stops all motion-interlocked gates and/or sensing devices. See Figure 67.

Figure 67
Robot Safeguarding

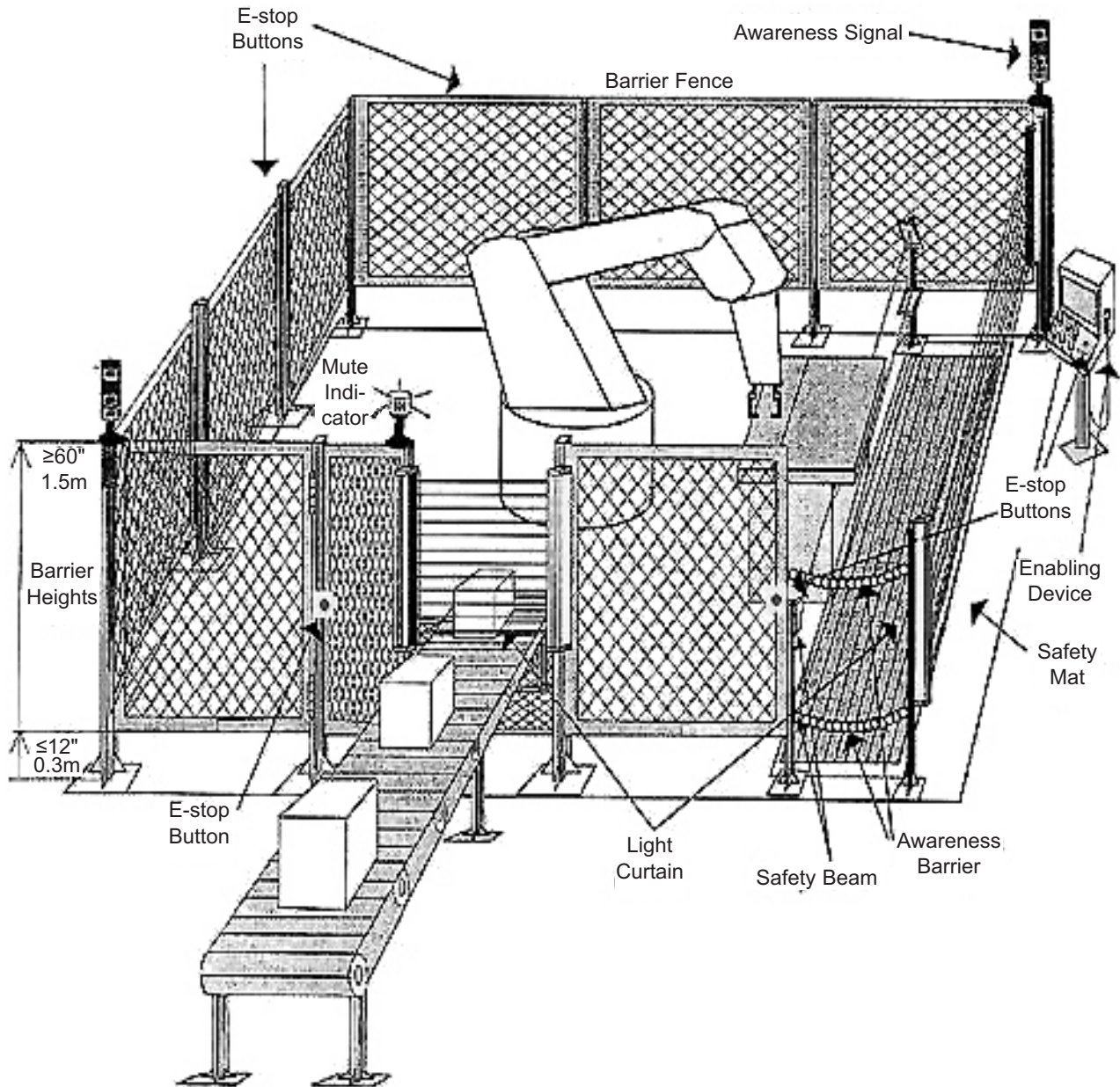

Safeguarding Basics

Perimeter Guarding:

- **Hard-Guarding:** This variety of guarding includes physical fencing and *interlocking safety latches*.
- May not be positioned any closer than the *restricted space*.

Barrier Guards—Interlocked Gates

- Open laterally or away from the hazard and not into the safeguarded space.
- Not be easily defeated.
- Positive break contacts.
- Cannot close by itself and activate the interlocking circuitry.

To ensure safe operating practices and safe installation of robots and robot systems, it is recommended that the minimum requirements of Section 5 of the ANSI/RIA R15.06-1992 (or later edition as appropriate), *Installation of Robots and Robot Systems*, be followed. In addition, OSHA's lockout/tagout standards (29 CFR 1910.147 and 1910.333) must be followed for servicing and maintenance.

General Requirements. To ensure minimum safe operating practices and safeguards for robots and robot systems addressed in this guide/covered by OSHA instruction, the following sections of the ANSI/RIA R15.06-1992 must also be considered:

1. Section 6—Safeguarding Personnel
2. Section 7—Maintenance of Robots and Robot Systems
3. Section 8—Testing and Start-up of Robots and Robot Systems
4. Section 9—Safety Training of Personnel

Other Pertinent Industry Standards

- ANSI/RIA R15.06-1999, Industrial Robots and Robot Systems—Safety Requirements
- 29 CFR 1910.212, General Requirements for All Machines
- General Duty Clause (N.C. Gen. Stat. § 95-129(1))

Safety Requirements

ANSI B11.20—*Safety Requirements for Integrated Manufacturing Systems*

- Robotically integrated bending solution (RIBS) (brings a robot into coordinated motion with a *press brake*).
- If any of the machine tools in the system is a B11 series machine, the system must comply with B11.20.

Miscellaneous Aids

While these aids do not give complete protection from machine hazards, they may provide the operator with an extra margin of safety. Sound judgment is needed in their application. Below are several examples of possible applications.

Awareness Barriers

The awareness barrier does not provide physical protection, but serves only to remind a person that he or she is approaching the danger area. Generally, awareness barriers are not considered adequate where continual exposure to the hazard exists.

Figure 68 shows a rope used as an awareness barrier on the rear of a power squaring shear. Although the barrier does not physically prevent a person from entering the danger area, it calls attention to it.

Figure 68

Rear View of Power Squaring Shear

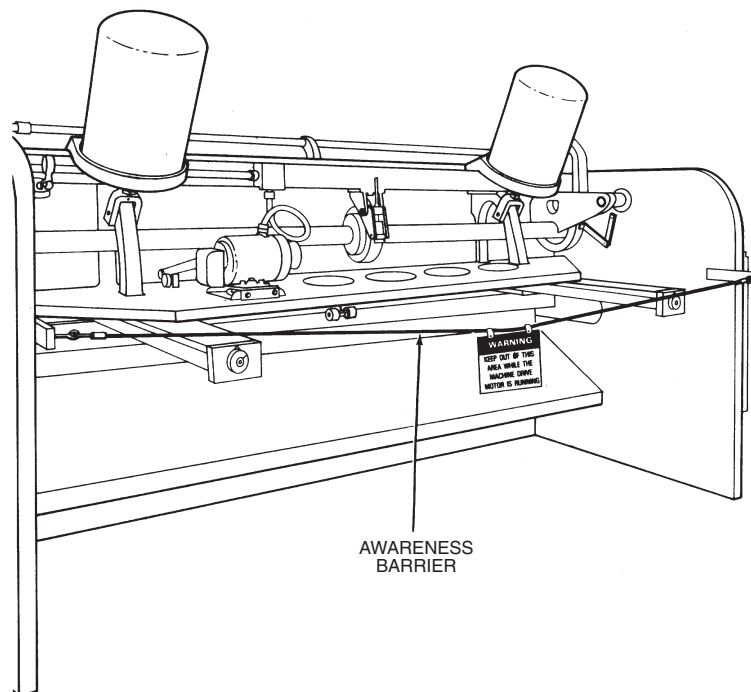

Miscellaneous Protective Shields

Figure 69 shows an awareness barrier on a stitching machine. Shields, another aid, may be used to provide protection from flying particles, splashing cutting oils or coolants.

Figure 69

Awareness Barrier on Stitching Machine

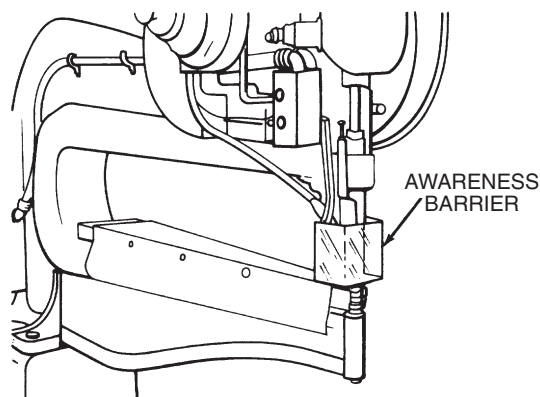
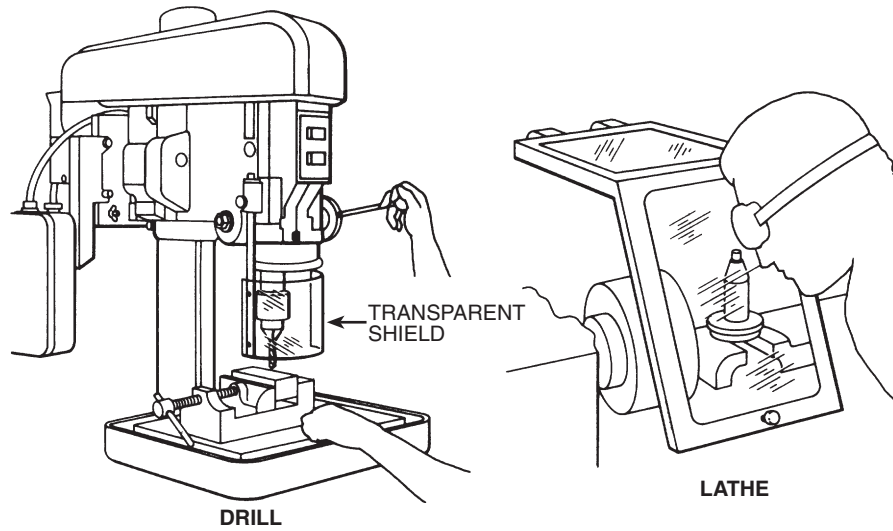

Figure 70 shows several potential applications for protective shields.

Figure 70

Protective Shields—Various Applications



Holding Fixtures and Hand-feeding Tools

A push stick or block, such as those in Figure 71, may be used when feeding stock into a saw blade.

Figure 71

Push Stick/Push Block

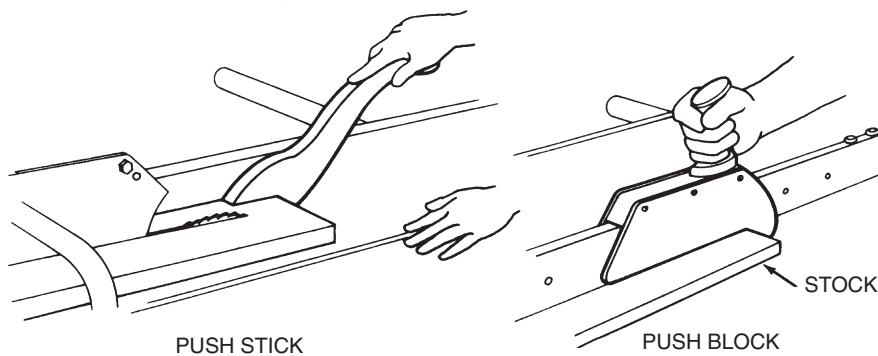

When it becomes necessary for hands to be in close proximity to the blade, the push stick or block may provide a few inches of safety and prevent a severe injury. In the above illustration, the push block fits over the fence.

Holding tools can place or remove stock. A typical use would be for reaching into the danger area of a press or press brake. Figure 72 shows an assortment of tools for this purpose. Note: The selection of “soft” tools will help avoid any damage that a holding tool might cause to presses or other machinery.

Figure 72

Holding Tools

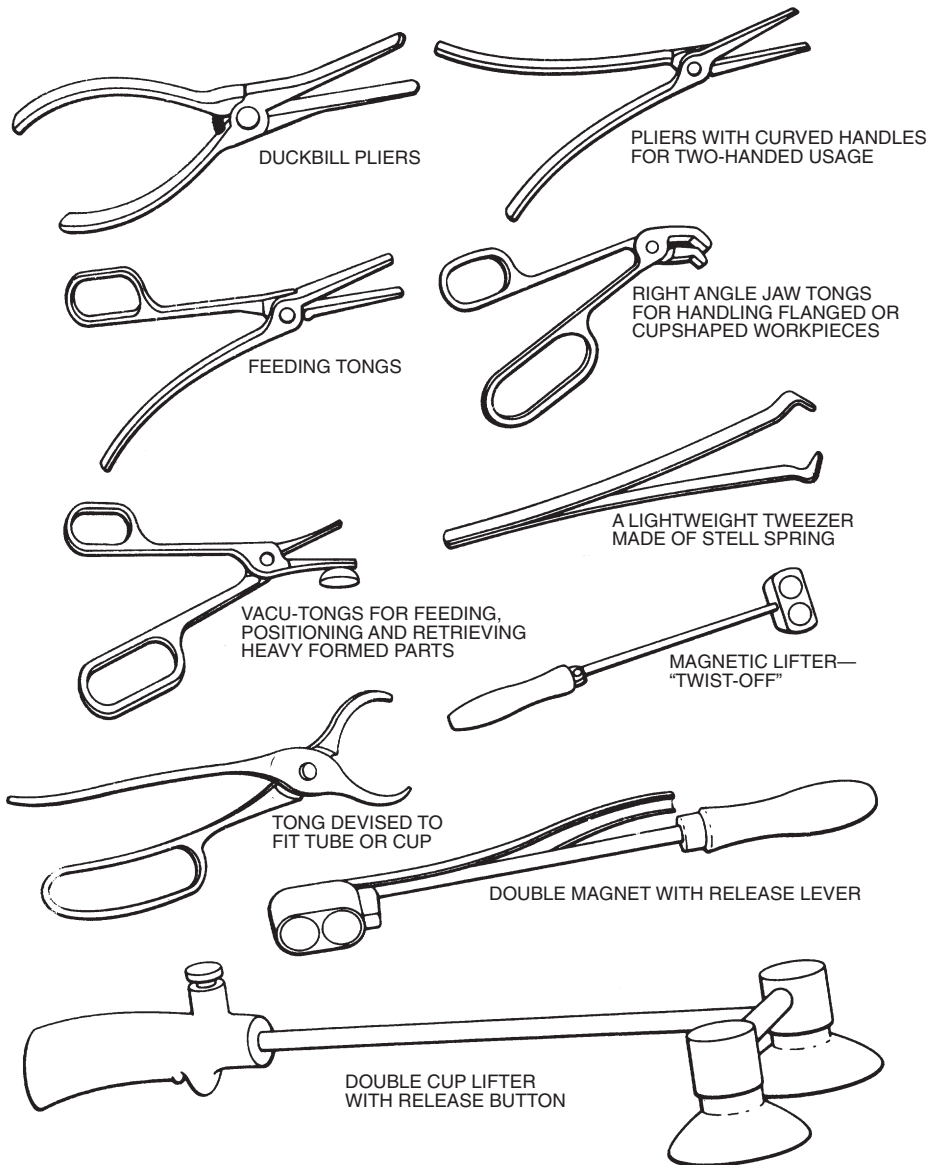

Robotics in the Workplace

Robot Applications

Robots are used to accomplish many different types of application functions such as material handling, assembly, arc welding, resistance welding, machine tool load/unload functions, and painting/spraying. Studies in Sweden and Japan indicate that many robot accidents have not occurred under normal operating conditions but rather during programming, program touchup, maintenance, repair, testing, setup or adjustment. During many of these operations, the operator, programmer or corrective maintenance worker may temporarily be within the robot's working envelope where unintended operations could result in injuries.

All industrial robots are either servo or non-servo controlled. Servo robots are controlled through the use of sensors that are employed continually to monitor the robot's axes for positional and velocity feedback information. This feedback information is compared on an ongoing basis to pretaught information that has been programmed and stored in the robot's memory. Non-servo robots do not have the feedback capability of monitoring the robot's axes and velocity and comparing with a pretaught program. Their axes are controlled through a system of mechanical stops and limit switches to control the robot's movement.

Type of Potential Hazards

The use of robotics in the workplace can also pose potential mechanical and human hazards. Mechanical hazards might include workers colliding with equipment, being crushed or trapped by equipment, or being injured by falling equipment components. For example, a worker could collide with the robot's arm or peripheral equipment as a result of unpredicted movements, component malfunctions or unpredicted program changes. A worker could be injured by being trapped between the robot's arm and other peripheral equipment or being crushed by peripheral equipment as a result of being impacted by the robot into this equipment.

Mechanical hazards can also result from the mechanical failure of components associated with the robot or its power source, drive components, tooling or end-effector, or peripheral equipment. Possible hazards include the failure of gripper mechanisms with resultant release of parts or the failure of end-effector power tools such as grinding wheels, buffing wheels, deburring tools, power screwdrivers and nut runners.

Human errors can result in hazards both to personnel and equipment. Errors in programming, interfacing peripheral equipment and connecting input/output sensors can all result in unpredicted movement or action by the robot, which can result in personnel injury or equipment breakage. Human errors in judgment result frequently from incorrectly activating the teach pendant or control panel. The greatest human judgment error results from becoming so familiar with the robot's redundant motions that personnel are too trusting in assuming the nature of these motions and place themselves in hazardous positions while programming or performing maintenance within the robot's work envelope.

Robots in the workplace are generally associated with the machine tools or process equipment. **Robots are machines** and as such must be safeguarded in ways similar to those presented for any hazardous remotely controlled machine.

Various techniques are available to prevent employee exposure to the hazards that can be imposed by robots. The most common technique is through the installation of perimeter guarding with interlocked gates. A critical parameter relates to the manner in which the interlocks function. Of major concern is whether the computer program, control circuit or the primary power circuit is interrupted when an interlock is activated. The various industry standards should be investigated for guidance; however, it is generally accepted that the primary motive power to the robot should be interrupted by the interlock.

The ANSI safety standard for industrial robots, ANSI/RIA R15.06-1999 (R2009), is very informative and presents certain basic requirements for protecting the worker. However, when a robot is to be used in a workplace, the employer should accomplish a comprehensive operational safety/health hazard analysis and then devise and implement an effective safeguarding system that is fully responsive to the situation. (Various effective safeguarding techniques are described in ANSI B11.19-2003 (R2009).)

The Utilization of Industry Consensus Standards

OSHA uses industry consensus standards, related to the safe operation of equipment, as guidance of the industry accepted practice for safe operations. Industry consensus standards that describe equipment configuration or design but that do not describe safe and/or healthful use and operation of the equipment are of limited assistance to OSHA. In any event, even when an industry consensus standard addresses safety/health considerations, OSHA may determine that the safety/health practices described by that industry consensus standard are deficient when related to the requirement(s) set forth by the pertinent OSHA regulation(s). However, many of the various ANSI safety standards devoted to the safe use of equipment and machines are pertinent and provide valuable guidance as they relate to the multitude of safe operating procedures regularly discussed in ANSI safety standards.

All of the requirements of **29 CFR 1910.212**, are applicable to machines found in industry. Paragraph (a)(1) requires that employees be protected from the hazards created by the point of operation, ingoing nip points, and rotating parts. Paragraph (a)(2) describes the manner in which guards must be affixed. The proper application of devices are not described; therefore, other similar OSHA or pertinent industry standards must be referred to for guidance. Paragraph (a)(3) describes, with particularity, the requirements for safeguarding the point of operation.

The OSHA standard specifically requires that at the point of operation, "the guarding device shall be in conformity with any appropriate standards therefor, or, in the absence of applicable specific standards, shall be so designed and constructed as to prevent the operator from having any part of his body in the danger zone during the operating cycle." Applicable standards include any similar OSHA standard or any OSHA-adopted industry consensus standards that provide for the safety of the operator during the operating cycle. However, any specific industry consensus standard, such as an ANSI standard for the particular machine or equipment, should be used for guidance relative to the accepted procedures for safeguarding workers and operators from the recognized hazards of the equipment.

OSHA encourages employers to abide by the more current industry consensus standards since those standards are more likely to be abreast of the state of the art than an applicable OSHA standard may be. Employers who comply with the requirements of an industry consensus standard, where such compliance deviates from the requirements of OSHA standard, should satisfy the intent of OSHA standard where such compliance provides equal or more conservative safeguarding concept as compared to a specific OSHA standard. Furthermore, the industry consensus standards will usually discuss a variety of techniques for averting exposure to the identified hazards of the machine or process.

Listing of Specific ANSI Safety Standards

ANSI B11.1-2009	Mechanical Power Presses
ANSI B11.2-1995 (R2005)	Hydraulic Power Presses
ANSI B11.3-2002 (R2007)	Power Press Brakes
ANSI B11.4-2003 (R2008)	Shears
ANSI B11.5-1988 (R2008)	Iron Workers
ANSI B11.6-2001 (R2007)	Lathes
ANSI B11.7-1995 (R2005)	Cold Headers and Cold Formers
ANSI B11.8-2001 (R2007)	Drilling, Milling and Boring Machines
ANSI B11.9-1975 (R2005)	Grinding Machines
ANSI B11.10-2003 (R2009)	Metal Sawing Machines
ANSI B11.11-2001 (R2007)	Gear Cutting Machines
ANSI B11.12-2005	Roll Forming and Roll Bending Machines
ANSI B11.13-1992 (R2007)	Single- and Multiple-Spindle Automatic Screw/Bar and Chucking Machines
ANSI B11.14-1996	Coil Slitting Machines/Equipment [Withdrawn and superseded by ANSI B11.18-2006]
ANSI B11.15-2001	Pipe, Tube, and Shape Bending Machines
ANSI B11.17-2004 (R2009)	Horizontal Hydraulic Extrusion Presses
ANSI B11.18-2006	Machinery and Systems for Processing or Slitting or Non-Coiled Metal Strip, Sheet or Plate
ANSI B11.19-2003 (R2009)	Machine Tools, Safeguarding
ANSI B11.20-2004 (R2009)	Manufacturing Systems/Cells
ANSI B15.1-2000 (R2008)	Power Transmission Apparatus
ANSI B19.1-1995	Air Compressor Systems [Withdrawn and not superseded]
ANSI B19.3-1991	Compressors for Process Industries [Withdrawn and not superseded]
ANSI B20.1-2009	Conveyors and Related Equipment
ANSI B24.1-1985 (R91)	Forging Machinery [Withdrawn and not superseded]
ANSI B28.6-1983	Rubber Machinery, Hose [Withdrawn and not superseded]
ANSI B28.7-1983	Rubber Machinery, Hose [Withdrawn and not superseded]
ANSI B28.8-1983	Rubber Machinery, Hose [Withdrawn and not superseded]
ANSI B28.9-1983	Rubber Machinery, Hose [Withdrawn and not superseded]
ANSI B28.10-1986	Rubber Machinery, Endless Belt [Withdrawn and not superseded]
ASME B30.16-2007	Overhead Hoists
ANSI B151.1-2007	Plastics Injection Molding Machinery, Horizontal
ANSI B151.2-1999	Plastics Machinery, Film Casting
ANSI B151.3-1982/88	Plastics Machinery, Screen Changers [Withdrawn and not superseded]
ANSI B151.4-1999	Plastics Machinery, Blown Film Takeoff and Auxiliary Equipment
ANSI B151.5-2000	Plastics Machinery, Film and Sheet Winding
ANSI B151.6-1982/88	Plastics Machinery, Slit Tape and Monofilament Postextrusion Equipment [Withdrawn and not superseded]
ANSI B151.7-1996	Plastics and Rubber Extrusion Machinery [Withdrawn and not superseded]
ANSI B151.11-1996	Plastics Machinery, Granulators, Pelletizers and Dicers [Withdrawn and not superseded]
ANSI B151.15-2003	Plastics Machinery, Extrusion Blow Molding
ANSI B151.21-2003	Plastics Machinery, Injection Blow Molding
ANSI B151.25-1988	Plastics Machinery, Injection Molding [Withdrawn and superseded by ANSI B151.26-1993]
ANSI B152.2-1982	Permanent-Mold Casting Machines (Other Than Gray Iron) [Withdrawn and not superseded]

ANSI B153.1-1990	Automotive Lifts [Withdrawn and superseded by ALI ALCTV-2006]
ANSI B155.1-2006	Packaging Machinery
ANSI B169.1-1990	Envelope Manufacturing Machinery [Withdrawn and not superseded]
ANSI B176-2008	Copper-Alloy Diecasting
ANSI B177.2-1997	Printing Ink Vertical Post Mixers [Withdrawn and not superseded]
ANSI/NEMA ICS 5-2000 (with 2008 errata)	Interlocking Control Systems: Control-circuit and Pilot Devices
ANSI/NFPA 79-2007 (2007 ERRATA)	Electrical Standard for Industrial Machinery
ANSI/RIA R15.06-1999	Industrial Robots and Robot Systems
ANSI Z8.1-2006	Commercial Laundry and Dry-Cleaning Equipment
ANSI Z241.1-1989	Foundry, Sand Preparation, Molding and Core-Making [Superseded by ASTM E2349-2009]
ANSI Z241.2-1999	Foundry, Melting and Pouring of Metals [Superseded by ASTM E2349-2009]
ANSI Z241.3-1999	Foundry, Cleaning and Finishing of Castings [Superseded by ASTM E2349-2009]
ANSI Z245.1-2008	Refuse Collecting and Compacting Equipment
ANSI Z245.3-1977/90	Stability of Refuse Bins
ANSI Z245.5-2008	Bailing Equipment
ANSI Z268.1-1982	Metal Scrap Processing Equipment [Withdrawn and not superseded]

3

Guard Construction

Today, many builders of single-purpose machines provide point-of-operation and power transmission safeguards as standard equipment. Not all machines have built-in safeguards provided by manufacturers; some must be specified in the purchase agreements.

Guards designed and installed by the builder offer two main advantages:

- They usually conform to the design and function of the machine.
- They can be designed to strengthen the machine in some way or to serve some additional functional purposes.

User-built guards are sometimes necessary for a variety of reasons. They have these advantages:

- Often, with older machinery, they are the only practical solution.
- They may be the only choice for mechanical power transmission apparatus in older plants, where machinery is not powered by individual motor drive.
- They permit options for point-of-operation safeguards when skilled personnel and machinery are available to make them.
- They can be designed and built to fit unique and even changing situations.
- They can be installed on individual dies and feeding mechanisms.
- Design and installation of machine safeguards by plant personnel can help to promote safety consciousness in the workplace.

However, they also have disadvantages:

- User-built guards may not conform well to the configuration and function of the machine.
- There is a risk that user-built guards may be poorly designed or built.

Point-of-Operation Guards

Point-of-operation guarding is complicated by the number and complexity of machines and also by the different uses for individual machines. For these reasons, not all machine builders provide point-of-operation guards on their products. In many cases, a point-of-operation guard can only be made and installed by the user after a thorough hazard analysis of the work requirements.

Because abrasive wheels are so pervasive, and because of the incidence of amputations from power press injuries, special attention is given here to the selection, positioning and construction of guards for grinders and mechanical power presses.

Grinders

Figure 73 shows a properly guarded abrasive wheel. Following Figure 73 is discussion of the properly guarded grinder. In addition to proper guarding the grinder operator would wear goggles or a face shield.

Figure 73

Properly Guarded Abrasive Wheel

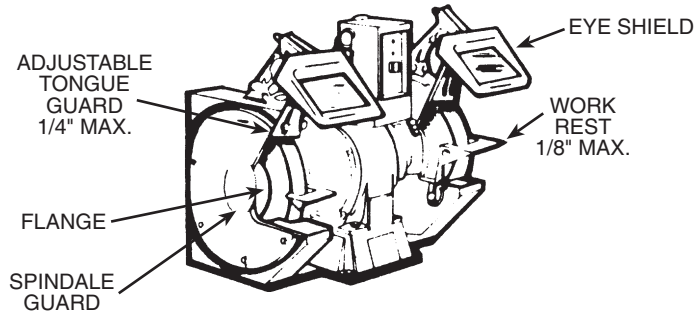

Wheel safety guards cover the spindle end, nut and flange projections. The exposed area of the grinding wheel does not exceed more than one-fourth of the area of the entire wheel. Note: When the guard opening is measured, the visors and other accessory equipment are not included as part of the guard unless they are as strong as the guard.

The work or tool rest is of strong construction and is adjustable to compensate for wheel wear. The work rest is kept closely adjusted to the wheel, to prevent the work from becoming jammed between the wheel and the work rest. The maximum clearance between the wheel and the work rest is $\frac{1}{8}$ inch.

The tongue guards (upper peripheral guards) are constructed so that they adjust to the wheel as it wears down. A maximum clearance of $\frac{1}{4}$ inch is allowed between the wheel and the tongue guard.

Figure 74 shows portable abrasive wheels, which should also be guarded by as complete an enclosure as practical. The operator of a portable grinder would also wear goggles or a face shield.

Figure 74

Portable Abrasive Wheels

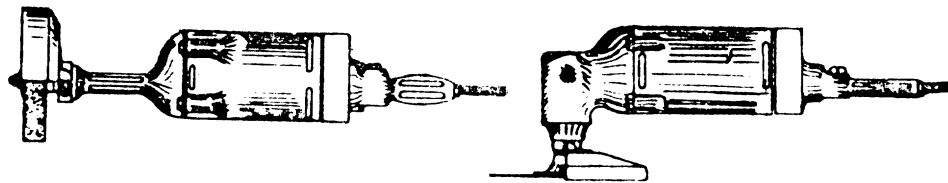

Mechanical Power Presses

Below are facts that should be observed by any person who operates or requires the operation of power presses.

1. Figure 75 shows the distances that guards should be positioned from the point of operation, in accordance with the required openings.
2. Power presses are exceptionally hazardous. Of the approximately 20,000 occupational amputations reported each year, almost 2,000 (10 percent) of the amputations occur to power press operators.
3. Mechanical power presses inflict particularly serious injury. Approximately one-half of injuries from mechanical power presses result in amputations.
4. Mechanical power presses that are manually operated with a foot control are involved in almost two-thirds of all mechanical power press injuries. Inadvertent activation of foot controls contributes significantly to injuries on mechanical power presses. Inadvertent activation increases when:
 - a. The operator is required to repeat the job task at a rate that is too fast. Each task should be studied to determine its "critical cycling rate," beyond which the rate is too fast and inadvertent activation of the foot control substantially increases.
 - b. The operator loses balance, or normal task rhythm is interrupted. A correct sitting work position reduces fatigue; foot strain is lessened by a foot rest positioned near the foot control.

Figure 75

Distances of Guards From Point of Operation

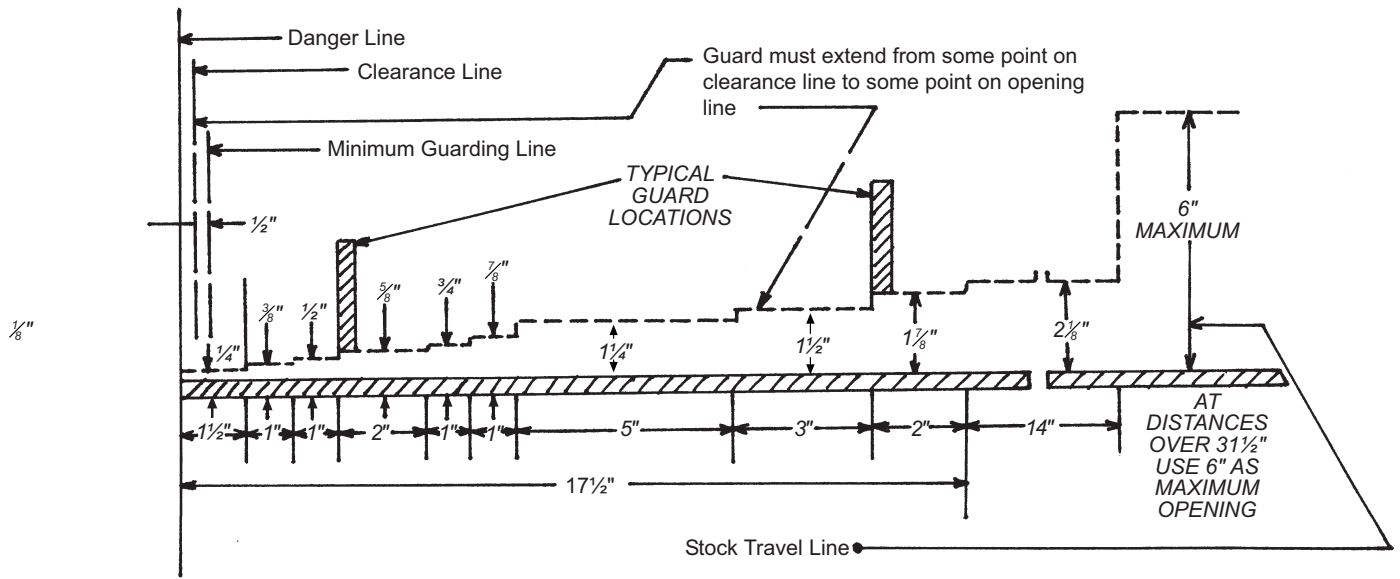

Explanation of Figure 75

The diagram shows the accepted safe openings between the bottom edge of a guard and feed table at various distance from the danger line (point of operation).

The *clearance line* marks the distances required to prevent contact between guard and moving parts.

The *minimum guarding line* is the distance between the infeed side of the guard and the danger line, which is one-half inch from the danger line.

The various openings are such that for average size hands an operator's fingers will not reach the point of operation.

After installation of point of operation guards and before a job is released for operation, a check should be made to verify that the guard will prevent the operator's hands from reaching the point of operation.

<i>Distance of opening from point of operation hazard (inches)</i>	<i>Maximum width of opening (inches)</i>
1/2 to 1 1/2	1/4
1 1/2 to 2 1/2	3/8
2 1/2 to 3 1/2	1/2
3 1/2 to 5 1/2	5/8
5 1/2 to 6 1/2	3/4
6 1/2 to 7 1/2	7/8
7 1/2 to 12 1/2	1 1/4
12 1/2 to 15 1/2	1 1/2
15 1/2 to 17 1/2	1 7/8
17 1/2 to 31 1/2	2 1/8

This table shows the distances that guards must be positioned from the danger line in accordance with the required openings.

- c. The operator "rides" the foot control (keeps the foot on the pedal without actually depressing it). Work rules should prohibit riding the foot control. The foot control should be set to require it to be fully depressed then released before the press cycle can be repeated.
 - d. Objects fall upon the foot control. There should be a guard or cover over the foot control.
5. Intentional deactivation or overriding of safeguards contributes to injuries on mechanical power presses. (Foot controls should be used in conjunction with point-of-operation safeguards that cannot be easily bypassed. Foot controls can be interlocked with other safeguards which, if not functioning, cause the foot control to be inoperable.)
 6. Attempts by the operator to correct the placement of a workpiece after the downstroke of the press has been initiated contributes to injuries on mechanical power presses. (Safeguards for foot-controlled mechanical power presses include devices that attach to the operator and physically restrain or pull back from the point of operation. Such devices must be adjusted for each operator.)

7. Mechanical power presses that are manually operated with dual palm buttons (two-hand controls) are involved in approximately one-third of all mechanical power press injuries. Dual palm buttons may be located so close to the die area that an operator can move his or her hands from the palm buttons to the point of operation before the ram has completed its downstroke. This “after-reach” hazard results from failure to account for differences in hand speed when fixing the dual palm buttons to the press. If any press operator exceeds the current OSHA hand-speed constant (found at 29 Code of Federal Regulations 1910.217(c)(3)(vii)(c)):
 - a. Additional safeguarding, such as fixed barrier guards, might be employed.
 - b. The palm buttons should be moved a greater distance from the press.
8. Palm buttons should be fixed in location so that only a supervisor or setup person can relocate them.
9. Operation of the palm buttons should require both hands if one operator is required or both hands of each person if more than one operator is required.
10. The press should be monitored frequently to ensure that the safety features of the palm buttons are not being bypassed.
11. Items 2 through 10 of the above information and additional information about mechanical presses are found in *Injuries and Amputations Resulting From Work With Mechanical Power Presses*, NIOSH (National Institute for Occupational Safety and Health) Current Intelligence Bulletin 49 (May 22, 1987), NIOSH Publication No. 87-107, www.cdc.gov/niosh/87107_49.html.

Mechanical Power Transmission Apparatus Guarding

A significant difference between power transmission guards and point-of-operation guards is that the former type needs no opening for feeding stock. The only openings necessary for power transmission guards are those for lubrication, adjustment, repair and inspection. These openings should be provided with covers that cannot be removed except by using tools for service or adjustment.

To be effective, power transmission guards should cover all moving parts in such a manner that no part of the operator’s body can come in contact with them.

Guard Material

Under many circumstances, metal is the best material for guards. Guard framework is usually made from structural shapes, pipe, bar or rod stock. Filler material generally is expanded or perforated or solid sheet metal or wire mesh. It may be feasible to use plastic or safety glass where visibility is required.

Guards made of wood generally are not recommended because of their flammability and lack of durability and strength. However, in areas where corrosive materials are present, wooden guards may be the better choice.

4

Machinery Maintenance and Repair

Good maintenance and repair procedures can contribute significantly to the safety of the maintenance crew as well as to that of machine operators. But the variety and complexity of machines to be serviced, the hazards associated with their power sources, the special dangers that may be present during machine breakdown, and the severe time constraints often placed on maintenance personnel all make safe maintenance and repair work difficult.

Training and aptitude of people assigned to these jobs should make them alert for the intermittent electrical failure, the worn part, the inappropriate noise, the cracks or other signs that warn of impending breakage or that a safeguard has been damaged, altered or removed. By observing machine operators at their tasks and listening to their comments, maintenance personnel may learn where potential trouble spots are and give them early attention before they develop into sources of accidents and injury. Sometimes all that is needed to keep things running smoothly and safely is machine lubrication or adjustment. Any damage observed or suspected should be reported to the supervisor; if the condition impairs safe operation, the machine should be taken out of service for repair. Safeguards that are missing, altered or damaged also should be reported so appropriate action can be taken to ensure against worker injury.

If possible, machine design should permit routine lubrication and adjustment without removal of safeguards. But when safeguards must be removed, the maintenance and repair crew must never fail to replace them before the job is considered finished.

Is it necessary to oil machine parts while a machine is running? If so, special safeguarding equipment may be needed solely to protect the oiler from exposure to hazardous moving parts. Maintenance personnel must know which machines can be serviced while running and which cannot. "If in doubt, lock it out."

Obviously, the danger of accident or injury is reduced by shutting off all sources of energy.

In situations where the maintenance or repair worker would necessarily be exposed to electrical elements or hazardous moving machine parts in the performance of the job, there is no question that power sources must be shut off and locked out before work begins. Warning signs or tags are inadequate insurance against the untimely energizing of mechanical equipment.

Thus, one of the first procedures for the maintenance person is to disconnect and lock out the machine from its power sources, whether the source is electrical, mechanical, pneumatic, hydraulic or a combination of these. Energy accumulation devices must be "bled down."

Electrical

Unexpected energizing of any electrical equipment that can be started by automatic or manual remote control may cause electric shock or other serious injuries to the machine operator, the maintenance worker or others operating adjacent machines controlled by the same circuit. For this reason, when maintenance personnel must repair electrically powered equipment, they should open the circuit at the switch box and padlock the switch (lock it out) in the "off" position. This switch should be tagged with a description of the work being done, the name of the maintenance person who should keep the key, and the department involved. See Figure 76.

Figure 76
Lockout Hasp

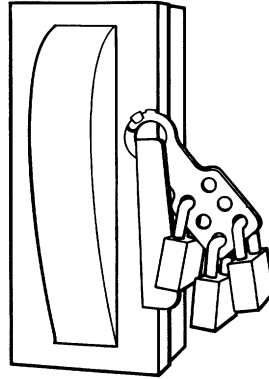

Mechanical and Gravitational

Figure 77 shows safety blocks being used as an additional safeguard on a mechanical power press, even though the machine has been locked out electrically.

Figure 77
Safety Blocks Installed on Power Press

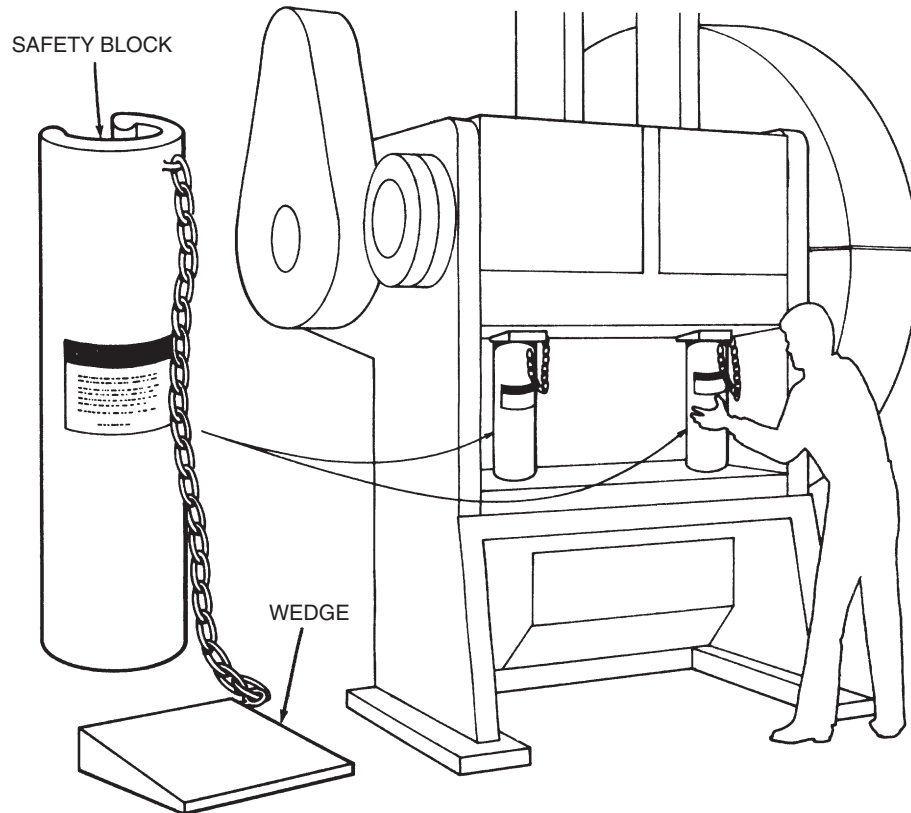

The safety blocks shown in Figure 77 prevent the ram from coming down under its own weight.

Pneumatic and Hydraulic

Figure 78 shows a lockout valve.

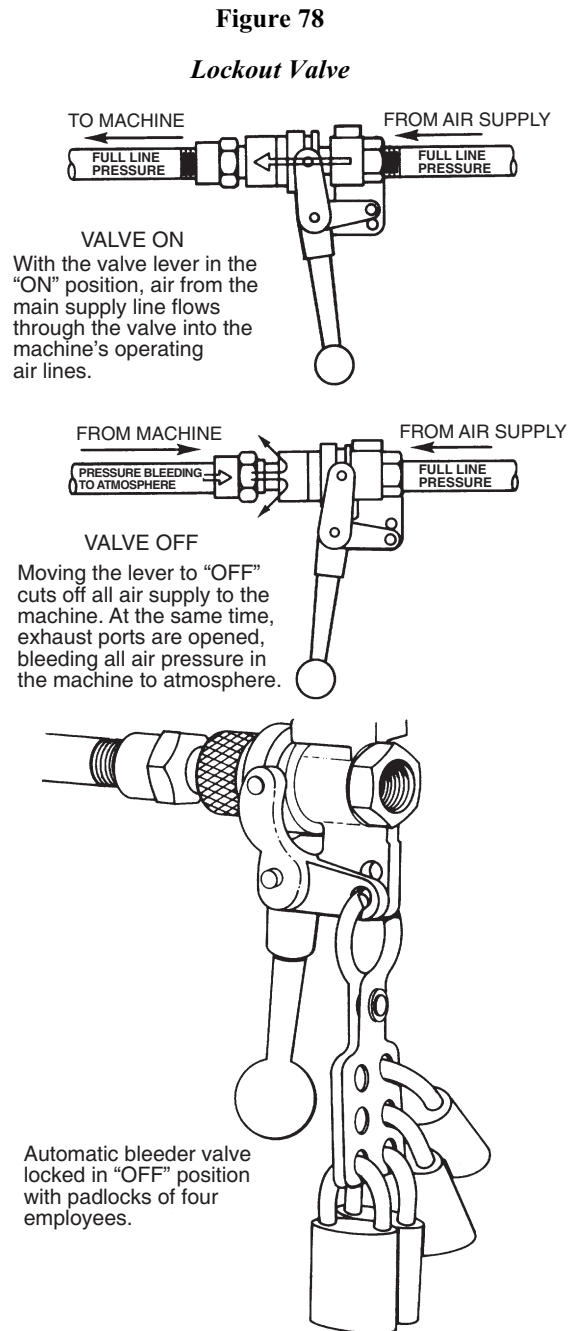

The lever-operated air valve used during repair or shutdown to keep a pneumatic-powered machine or its components from operating can be locked open or shut. Before the valve can be opened, everyone working on the machine must use his or her own key to release the lockout. A sliding-sleeve valve exhausts line pressure at the same time it cuts off the air supply. Valves used to lock out pneumatic or hydraulic-powered machines should be designed to accept locks or lockout adapters and should be capable of "bleeding off" pressure residues that could cause any part of the machine to move.

In shops where several maintenance persons might be working on the same machine, multiple lockout devices accommodating several padlocks are used. The machine can't be reactivated until each person removes his or her lock. As a matter of general policy, lockout control is gained by the simple procedure of issuing personal padlocks to each maintenance or repair person; no one but that person can remove the padlock when work is completed, reopening the power source on the machine just serviced.

Following are the steps of a typical lockout procedure that can be used by maintenance and repair crews:

1. Alert the operator and supervisor.
2. Identify all sources of residual energy.
3. Before starting work, place padlocks on the switch, lever or valve, locking it in the “off” position, installing tags at such locations to indicate maintenance in progress.
4. Ensure that all power sources are off, and “bleed off” hydraulic or pneumatic pressure, or “bleed off” any electrical current (capacitance), as required, so machine components will not accidentally move.
5. Test operator controls.
6. After maintenance is completed, all machine safeguards that were removed should be replaced, secured and checked to be sure they are functioning properly.
7. Only after ascertaining that the machine is ready to perform safely should padlocks be removed and the machine cleared for operation.

The maintenance and repair facility in the plant deserves consideration here. Are all the right tools on hand and in good repair? Are lubricating oils and other common supplies readily available and safely stored? Are commonly used machine parts and hardware kept in stock so that the crews are not encouraged (even obliged) to improvise, at the risk of doing an unsafe repair, or to postpone a repair job? And don't overlook the possibility that maintenance equipment itself may need guarding of some sort. The same precaution applies to tools and machines used in the repair shop. Certainly, the maintenance and repair crew are entitled to the same protection that their service provides to the machine operators in the plant.

5

Cooperation and Assistance

Safety in the workplace demands cooperation and alertness on everyone's part. Supervisors, operators and other workers who notice hazards in need of safeguarding or existing systems that need repair or improvement should notify the proper authority immediately.

Supervisors have these additional special responsibilities with regard to safety in the workplace: encouraging safe work habits and correcting unsafe ones; explaining to the workers all the potential hazards associated with the machines and processes in the work area; and being responsive to employer requests for action or information regarding machine hazards. The first-line supervisor plays a pivotal role in communicating the safety needs of the workers to management and the employer's safety rules and policies to the workers.

Sometimes the solution to a machine safeguarding problem may require expertise that is not available in a given establishment. The readers of this manual are encouraged to find out where help is available and, when necessary, to request it.

A machine's manufacturer is often a good place to start when looking for assistance with a safeguarding problem. Manufacturers can often supply the necessary literature or advice. Insurance carriers, too, will often make their safety specialists available to the establishments whose assets they insure. Union safety specialists can also lend significant assistance.

An important source of information and assistance is the Occupational Safety and Health Division of the N.C. Department of Labor. Within the OSH Division are the Education, Training and Technical Assistance Bureau and the Consultative Services Bureau. Both bureaus are separate from the Compliance Bureau. Neither the Education, Training and Technical Assistance Bureau nor the Consultative Services Bureau issues citations for violations of occupational safety and health standards. Assistance from both bureaus is free. For information on where to write or to telephone for information or assistance, see the inside of the back cover of this publication.

Checklist

Answers to the following questions should help the interested reader to determine the safeguarding needs of his or her own workplace, by drawing attention to hazardous conditions or practices requiring correction.

	Yes	No
Requirements for All Safeguards		
1. Do the safeguards provided meet the minimum OSHA requirements?	<input type="checkbox"/>	<input type="checkbox"/>
2. Do the safeguards prevent workers' hands, arms and other body parts from making contact with dangerous moving parts?	<input type="checkbox"/>	<input type="checkbox"/>
3. Are the safeguards firmly secured and not easily removable?	<input type="checkbox"/>	<input type="checkbox"/>
4. Do the safeguards ensure that no objects will fall into the moving parts?	<input type="checkbox"/>	<input type="checkbox"/>
5. Do the safeguards permit safe, comfortable and relatively easy operation of the machine?	<input type="checkbox"/>	<input type="checkbox"/>
6. Can the machine be oiled without removing the safeguard?	<input type="checkbox"/>	<input type="checkbox"/>
7. Is there a system for shutting down the machinery before safeguards are removed?	<input type="checkbox"/>	<input type="checkbox"/>
8. Can the existing safeguards be improved?	<input type="checkbox"/>	<input type="checkbox"/>
Mechanical Hazards		
<i>The point of operation:</i>		
1. Is there a point-of-operation safeguard provided for the machine?	<input type="checkbox"/>	<input type="checkbox"/>
2. Does it keep the operator's hands, fingers and body out of the danger area?	<input type="checkbox"/>	<input type="checkbox"/>
3. Is there evidence that the safeguards have been tampered with or removed?	<input type="checkbox"/>	<input type="checkbox"/>
4. Could you suggest a more practical, effective safeguard?	<input type="checkbox"/>	<input type="checkbox"/>
5. Could changes be made on the machine to eliminate the point-of-operation hazard entirely?	<input type="checkbox"/>	<input type="checkbox"/>
<i>Power transmission apparatus:</i>		
1. Are there any unguarded gears, sprockets, pulleys or fly-wheels on the apparatus?	<input type="checkbox"/>	<input type="checkbox"/>
2. Are there any exposed belts or chain drives?	<input type="checkbox"/>	<input type="checkbox"/>
3. Are there any exposed set screws, key ways or collars?	<input type="checkbox"/>	<input type="checkbox"/>
4. Are starting and stopping controls within easy reach of the operator?	<input type="checkbox"/>	<input type="checkbox"/>
5. If there is more than one operator, are separate controls provided?	<input type="checkbox"/>	<input type="checkbox"/>
<i>Other moving parts:</i>		
1. Are safeguards provided for all hazardous moving parts of the machine, including auxiliary parts?	<input type="checkbox"/>	<input type="checkbox"/>
Nonmechanical Hazards		
1. Have appropriate measures been taken to safeguard workers against noise hazards?	<input type="checkbox"/>	<input type="checkbox"/>
2. Have special guards, enclosures or personal protective equipment been provided, where necessary, to protect workers from exposure to harmful substances used in machine operation?	<input type="checkbox"/>	<input type="checkbox"/>
Electrical Hazards		
1. Is the machine installed in accordance with National Fire Protection Association and National Electrical Code requirements?	<input type="checkbox"/>	<input type="checkbox"/>
2. Are there loose conduit fittings?	<input type="checkbox"/>	<input type="checkbox"/>
3. Is the machine properly grounded?	<input type="checkbox"/>	<input type="checkbox"/>
4. Is the power supply correctly fused and protected?	<input type="checkbox"/>	<input type="checkbox"/>
5. Do workers occasionally receive minor shocks while operating any of the machines?	<input type="checkbox"/>	<input type="checkbox"/>

Training

1. Do operators and maintenance workers have the necessary training in how to use the safeguards and why?
2. Have operators and maintenance workers been trained in where the safeguards are located, how they provide protection, and what hazards they protect against?
3. Have operators and maintenance workers been trained in how and under what circumstances guards can be removed?
4. Have workers been trained in the procedures to follow if they notice guards that are damaged, missing or inadequate?

Protective Equipment and Proper Clothing

1. Is protective equipment required?
2. If protective equipment is required, is it appropriate for the job, in good condition, kept clean and sanitary, and stored carefully when not in use?
3. Is the operator dressed safely for the job (that is, no loose-fitting clothing or jewelry)?

Machinery Maintenance and Repair

1. Have maintenance workers received up-to-date instruction on the machinery they service?
2. Do maintenance workers lock out the machine from its power sources before beginning repairs?
3. Where several maintenance persons work on the same machine, are multiple lockout devices used?
4. Do maintenance persons use appropriate and safe equipment in their repair work?
5. Is the maintenance equipment itself properly guarded?

Other Items to Check

1. Are emergency stop buttons, wires or bars provided?
2. Are the emergency stops clearly marked and painted red?
3. Are there warning labels or markings to show hazardous areas?
4. Are the warning labels or markings appropriately identified by yellow, yellow and black, or orange colors?

OSH Publications

We provide a variety of OSH publications. These include general industry and construction regulations, industry guides that cover different OSH topics, quick cards, fact sheets and brochures that cover a wide variety of serious safety and health workplace hazards. Workplace labor law posters are available free of charge. To obtain publications, call toll free at 1-800-NC-LABOR (1-800-625-2267) or direct at 919-807-2875. You may view the list of publications and also download many of them at **www.nclabor.com/pubs.htm**.

Occupational Safety and Health (OSH)

Sources of Information

You may call 1-800-NC-LABOR (1-800-625-2267) to reach any division of the N.C. Department of Labor; or visit the NCDOL home page on the World Wide Web: <http://www.nclabor.com>.

Occupational Safety and Health Division

Mailing Address:
1101 Mail Service Center
Raleigh, NC 27699-1101
Local Telephone: 919-807-2900 Fax: 919-807-2856

Physical Location:
111 Hillsborough St.
(Old Revenue Building, 3rd Floor)

For information concerning education, training, interpretations of occupational safety and health standards, and OSH recognition programs contact:

Education, Training and Technical Assistance Bureau

Mailing Address:
1101 Mail Service Center
Raleigh, NC 27699-1101
Telephone: 919-807-2875 Fax: 919-807-2876

Physical Location:
111 Hillsborough St.
(Old Revenue Building, 4th Floor)

For information concerning occupational safety and health consultative services contact:

Consultative Services Bureau

Mailing Address:
1101 Mail Service Center
Raleigh, NC 27699-1101
Telephone: 919-807-2899 Fax: 919-807-2902

Physical Location:
111 Hillsborough St.
(Old Revenue Building, 3rd Floor)

For information concerning migrant housing inspections and other related activities contact:

Agricultural Safety and Health Bureau

Mailing Address:
1101 Mail Service Center
Raleigh, NC 27699-1101
Telephone: 919-807-2923 Fax: 919-807-2924

Physical Location:
111 Hillsborough St.
(Old Revenue Building, 2nd Floor)

For information concerning occupational safety and health compliance contact:

Safety and Health Compliance District Offices

Raleigh District Office (3801 Lake Boone Trail, Suite 300, Raleigh, NC 27607)
Telephone: 919-779-8570 Fax: 919-420-7966

Asheville District Office (204 Charlotte Highway, Suite B, Asheville, NC 28803-8681)
Telephone: 828-299-8232 Fax: 828-299-8266

Charlotte District Office (901 Blairhill Road, Suite 200, Charlotte, NC 28217-1578)
Telephone: 704-665-4341 Fax: 704-665-4342

Winston-Salem District Office (4964 University Parkway, Suite 202, Winston-Salem, NC 27106-2800)
Telephone: 336-776-4420 Fax: 336-767-3989

Wilmington District Office (1200 N. 23rd St., Suite 205, Wilmington, NC 28405-1824)
Telephone: 910-251-2678 Fax: 910-251-2654

To make an OSH Complaint, **OSH Complaint Desk:** 919-807-2796

For statistical information concerning program activities contact:

Planning, Statistics and Information Management Bureau

Mailing Address:
1101 Mail Service Center
Raleigh, NC 27699-1101
Telephone: 919-807-2950 Fax: 919-807-2951

Physical Location:
111 Hillsborough St.
(Old Revenue Building, 2nd Floor)

For information about books, periodicals, vertical files, videos, films, audio/slide sets and computer databases contact:

N.C. Department of Labor Library

Mailing Address:
1101 Mail Service Center
Raleigh, NC 27699-1101
Telephone: 919-807-2850 Fax: 919-807-2849

Physical Location:
111 Hillsborough St.
(Old Revenue Building, 5th Floor)

N.C. Department of Labor (Other than OSH)

1101 Mail Service Center
Raleigh, NC 27699-1101
Telephone: 919-733-7166 Fax: 919-733-6197