

Breathing hoses do not need to be in straps on test apparatus ____2

**STATEMENTS OF FACT
BENCH BIOPAK 240-R CONTEST**

1. Use only exact replacement parts in the configuration as specified by the manufacturer. User/Benchman: Cautions and Limitations, Special or Critical User's Instructions)
2. The battery is to be changed in fresh air only. User/Benchman: Cautions and Limitations, Special or Critical User's Instructions)
3. MSHA approved for use with one of the following 9-Volt batteries only:
Eveready
Panasonic
Rayovac
Duracell
(Remote Monitoring System MSHA Electronic Approval Page)
4. Never substitute, modify, add or omit parts. User/Benchman: Cautions and Limitations, Special or Critical User's Instructions)
5. Prior to using the BioPak 240 Revolution it must be determined that the user is medically fit. User/Benchman: Cautions and Limitations, Special or Critical User's Instructions)
6. Always handle oxygen cylinders with care to prevent damage.
User/Benchman: Cautions and Limitations, Special or Critical User's Instructions)
7. Do not open the cylinder valve in the presence of open flame, sparks or high radiant heat. User/Benchman: Cautions and Limitations, Special or Critical User's Instructions)
8. Oxygen will enhance the combustion of other materials so that materials that normally will not burn in air may burn in oxygen-rich atmospheres; and, materials that do burn in air will burn more vigorously and at a higher temperature in oxygen-rich atmospheres. User/Benchman: Cautions and Limitations, Special or Critical User's Instructions)
9. Oxygen will not cause materials to ignite without the presence of an ignition source. User/Benchman: Cautions and Limitations, Special or Critical User's Instructions)
10. The use of an SCBA will add to the workload and stress of the user.
User/Benchman: Cautions and Limitations, Special or Critical User's Instructions)
11. The BioPak 240 Revolution is suitable for respiratory protection entry into and escape from oxygen deficient atmospheres with a temperature as low as -5 degrees F (-5F) (-20C). (Users/Benchman Cautions and Limitations or Critical User's Instructions)

12. The BioPak 240 Revolution is approved when the oxygen cylinder is fully charged with compressed medical or aviation grade oxygen at 3000 psi. User/Benchman: Cautions and Limitations, Special or Critical User's Instructions)
13. Allow the oxygen cylinder to cool after filling to determine the correct pressure. User/Benchman: Cautions and Limitations, Special or Critical User's Instructions)
14. A foreign gas may cause cylinder corrosion. User/Benchman: Cautions and Limitations, Special or Critical User's Instructions)
15. Always check for a current hydrostatic test date. User/Benchman: Cautions and Limitations, Special or Critical User's Instructions)
16. DOT requires carbon fiber wrapped aluminum cylinders be tested by an approved facility on a 5-year cycle from the date of manufacture. User/Benchman: Cautions and Limitations, Special or Critical User's Instructions)
17. An unapproved facepiece will compromise the protection provided to the user by the SCBA. User/Benchman: Cautions and Limitations, Special or Critical User's Instructions)
18. A good facepiece seal is important to achieving full protection and proper SCBA duration. User/Benchman: Cautions and Limitations, Special or Critical User's Instructions)
19. Users should conform to MSHA/NIOSH guidelines concerning facial hair and the use of facemasks. (Users/Benchman Cautions and Limitations or Critical User's Instructions)
20. Replace the battery when the low battery alarm has activated, after 200 hours of use or every 6 months whichever comes first. (Benchman section 3.4)
21. The connectors of the monitoring device may only be connected to a Bio marine BioPak 240R breathing Apparatus oxygen regulator, manifold block and breathing chamber. User/Benchman: Cautions and Limitations, Special or Critical User's Instructions)
22. The fiber optic cable may only be connected to the BioPak 240R remote gauge assembly. User/Benchman: Cautions and Limitations, Special or Critical User's Instructions)

23. Turn-Around maintenance procedures should be performed as soon as possible after each use. (Benchman Section 3.1)
24. It is acceptable to leave the oxygen cylinder in place until after washing and disinfecting has been completed. (Benchman Section 1.2)
25. Immediately after completion of BioPak use, remove the used CO2 scrubber canisters. (Benchman: Section 1.2)
26. DO NOT submerge the Alarm Module during turn-around maintenance. (Benchman: Section 1.3)
27. Do not allow any fluids to contact the in input port of the pressure regulator. (Benchman: Section 1.3)
28. Use only cleaners and disinfectants that are approved by Bio marine. (Benchman: Section 1.3)
29. If Cleaning is not immediately possible after each use, at a minimum remove and discard the CO2 scrubber and moisture pad. (Benchman: Section 1.3)
30. Remove the oxygen cylinder making sure the seal washer remains in place and install the regulator cover. (Benchman: Section 1.2)
31. Allow all components to remain wetted by the cleaning solution a minimum of 10 minutes. (Benchman: Section 1.3)
32. Thoroughly rinse all components in clean water to remove all disinfectant solution. (Benchman: Section 1.3)
33. C.O.P.D. could limit or prevent the use of the BioPak 240 Revolution. (User/Benchman: Cautions and Limitations, Special or Critical User's Instructions)
34. Place freeze forms onto a level surface in a freezer for a minimum of 8 hour period at a temperature of 10 degrees F or less. (Benchman: Section 1.4)
35. If the optional magnetic wiper is utilized soak both chamois surfaces of the wiper pieces with water. (User: Section 3.2)
36. The manual(s) are the minimum recommended procedures for maintaining the BioPak 240R. (User/Benchman: Cautions and Limitations, Special or Critical User's Instructions)
37. Failure to follow the minimum procedures presented in the manual(s) may violate government or agency approvals as well as void the

manufacturer's warranty. (User/Benchman: Cautions and Limitations, Special or Critical User's Instructions)

38. To prevent mold growth remove the moisture control foam pads after each use (Benchman: Section 1.3)
39. Do not pre-pack any BioPak that will be stored at temperatures at or below 32 degrees F. (Benchman: Section 1.12)
40. Pre-packing the BioPak 240 R with carbon dioxide scrubbers is only permitted when utilizing Orbsorb carbon dioxide scrubber. (Benchman: Section 1.12)
41. Pre-packed carbon dioxide scrubbers may only be stored in the apparatus for a maximum period of 1-year. (Benchman: Section 1.12)
42. Moisture control sponges must be installed dry when pre-packing the BioPak. (Benchman: Section 1.12)
43. Apparatus that are pre-packed with the carbon dioxide scrubber shall be stored within the specific storage temperature and humidity levels and must be sealed air-tight in the apparatus. (Benchman: Section 1.12)
44. Failure to install the moisture pad will result in scrubber flooding and cause elevated carbon dioxide levels in the inhalation gas. (Benchman: Section 1.12)
45. Users are not permitted to mix versions of the Orbsorb within a BioPak. (Benchman: Section 1.12)
46. Install two carbon dioxide scrubber canisters into the breathing chamber making sure that they are properly aligned and fully seated. (Benchman: Section 1.12)
47. The alarm system battery shall be replaced after 200-hours of use, every 6-months or after the alarm system low battery alarm flashes with corresponding horn sounding. (Benchman: Section 3.4)
48. The oxygen cylinder must be fully charged to above 1500 psi to perform a high pressure leak test. (Benchman: Section 2.6)
49. Use caution when installing the flow restrictor to insure that the O-ring does not roll out of its gland. (Benchman: Section 3.5)
50. The Cylinder should be inspected regularly for signs of damage to the outer

wrapping. (Benchman: Section 3.3)

51. The Turn-Around Maintenance Tag should be attached to the apparatus in a prominent location to show completion of all maintenance steps. (Benchman: Section 1.1)
52. In addition to normal Turn-Around Maintenance, the SCBA shall be visually inspected and pressure tested on a monthly basis if the apparatus is being used at least once a month or is placed in long term storage. (Benchman Section: 2)
53. BioPaks that have been placed in long term storage should have the Long Term Maintenance Procedure conducted every-6 months. (Benchman: Section 2)
54. The LED indication will cease when the pressure gauge reads less than 25 psi. (Benchman: Section 1.10)
55. Never pry an O-ring from its glands with a screwdriver. Remove O-rings by hand or with the pick tool provided in the service kit. (Benchman: Section 3.2)
56. Cristo-Lube and Dow-111 are the only lubricants approved for use in the apparatus. (Benchman: Section 3.2)
57. Never lubricate the sealing washer that sits between the oxygen cylinder and the pressure regulator. (Benchman: Section 3.2)
58. Cylinders that have been hydro-static tested shall be cleaned for high-pressure oxygen service per national standards. (Benchman: Section 3.2)
59. Cylinders are to be retired from service 15-years after the date of manufacture. (Benchman: Section 3.2)
60. The Alarm module will require replacement if any damage to the housing is discovered. (Benchman: Section 3.)
61. If the flow does not meet the requirements of the table in the Bench Manual the flow restrictor will need replacement. (Benchman: Section 1.8)
62. A good facemask seal is important to achieving full protection and duration. (User/Benchman: Cautions and Limitations, Special or Critical User's Instructions)

63. Personnel who intend to use protective breathing equipment in a dangerous atmosphere must have the proper training, temperament and experience. (User/Benchman: Cautions and Limitations, Special or Critical User's Instructions)
64. A clean shaven user will significantly increase the chances of achieving an adequate face seal. (User/Benchman: Cautions and Limitations, Special or Critical User's Instructions)
65. The ongoing effectiveness and reliability of any protective breathing equipment is dependent upon the user's standard of care in maintaining the equipment. (User/Benchman: Cautions and Limitations, Special or Critical User's Instructions)
66. The BioPak has been tested for intrinsic safety in methane-air mixtures only. (User/Benchman: Cautions and Limitations, Special or Critical User's Instructions)
67. The battery is to be changed in fresh air only. Do not change in hazardous areas. (User/Benchman: Cautions and Limitations, Special or Critical User's Instructions)
68. The BioPak is a Self-Contained Closed Circuit Pressure Demand type certified as Entry and Escape with a 4-hour duration. (Benchman: Section 6)
69. The constant Add is 1.8 liters average. (Benchman: Section 6)
70. The Demand Add flow is a minimum 80 liters per minute. (Benchman: Section 6)
71. The oxygen cylinder has a volume of 440 liters at 3000 psi. (Benchman: Section 6)
72. The BioPak breathing chamber has a Tidal Volume greater than 6 liters. (Benchman: Section 6)
73. For extreme temperature ranges, the BioPak should be configured with ice coolers. When ambient temperatures are greater than 140 degrees F the recommended duration is no more than 15 minutes and is limited by human endurance. (Benchman: Section 6)
74. The emergency Add has a minimum flow rate of 80 liters per minute. (Benchman: Section 6)
75. The BioPak operational conditions as it relates to relative humidity is 0 to 100%. (Benchman: Section 6)

76. BioPak weight fully charged is 34 pounds. (Benchman: Section 6)
77. Do not re-use CO2 scrubber chemical. (User/Benchman: Cautions and Limitations, Special or Critical User's Instructions)
78. The flow test results at 0-5280 feet at a cylinder pressure of 1500-2000 shall be 1.8-2.4 liters per minute. (Benchman: Section 1.8)
79. During an alarm test the LED indication should turn to a flashing red with a horn sounding when the pressure gauge reads between 650-1000 psi. (Benchman: Section 1.10)
80. Do not allow oil, grease or other foreign materials to come in contact with cylinder, cylinder valve or cylinder pressure regulator to prevent possible ignition. (User/Benchman: Cautions and Limitations, Special or Critical User's Instructions)
81. The end of service life or low Oxygen alarm is a flashing red light and horn sounding. (User: Section 2.7)
82. The flashing blue light indicates an Ice Reminder. (User: Section 2.7)
83. The pressure gauge is protected against sudden loss of oxygen in the event of a gauge line severing by a manual disconnect located at the gauge pass through point of the housing. (User: Section 2.7)
84. A Pacemaker or other Cardiac Condition could limit or prevent the use of the BioPak 240 Revolution. (User/Benchman: Cautions and Limitations, Special or Critical User's Instructions)
85. Breathing difficulties could limit or prevent the use of the BioPak 240 Revolution. (User/Benchman: Cautions and Limitations, Special or Critical User's Instructions)
86. Claustrophobia or anxiety when wearing a SCBA could limit or prevent the use of the BioPak 240 Revolution. (User/Benchman: Cautions and Limitations, Special or Critical User's Instructions)
87. The instructions provided by the USER and BENCHMAN manuals cannot replace accredited training provided by qualified instructors in the proper and safe use of Bio marine breathing apparatus. (User: Section 1.3)
88. X-Ray evidence of Pneumonia could limit or prevent the use of the BioPak 240 Revolution. (User/Benchman: Cautions and Limitations, Special or Critical User's Instruction)

89. Epilepsy-Grand Mal or Petit Mal could limit or prevent the use of the BioPak 240 Revolution. (User/Benchman: Cautions and Limitations, Special or Critical User's Instructions)
90. Use the 1/4 inch hex driver from the service Kit to remove the flow restrictor. (Benchman Section 3.5)

NOTE: The References listed above for the Statements of Facts can be down loaded for free from Bio-marine's web site.

BioPak 240 Revolution Complete

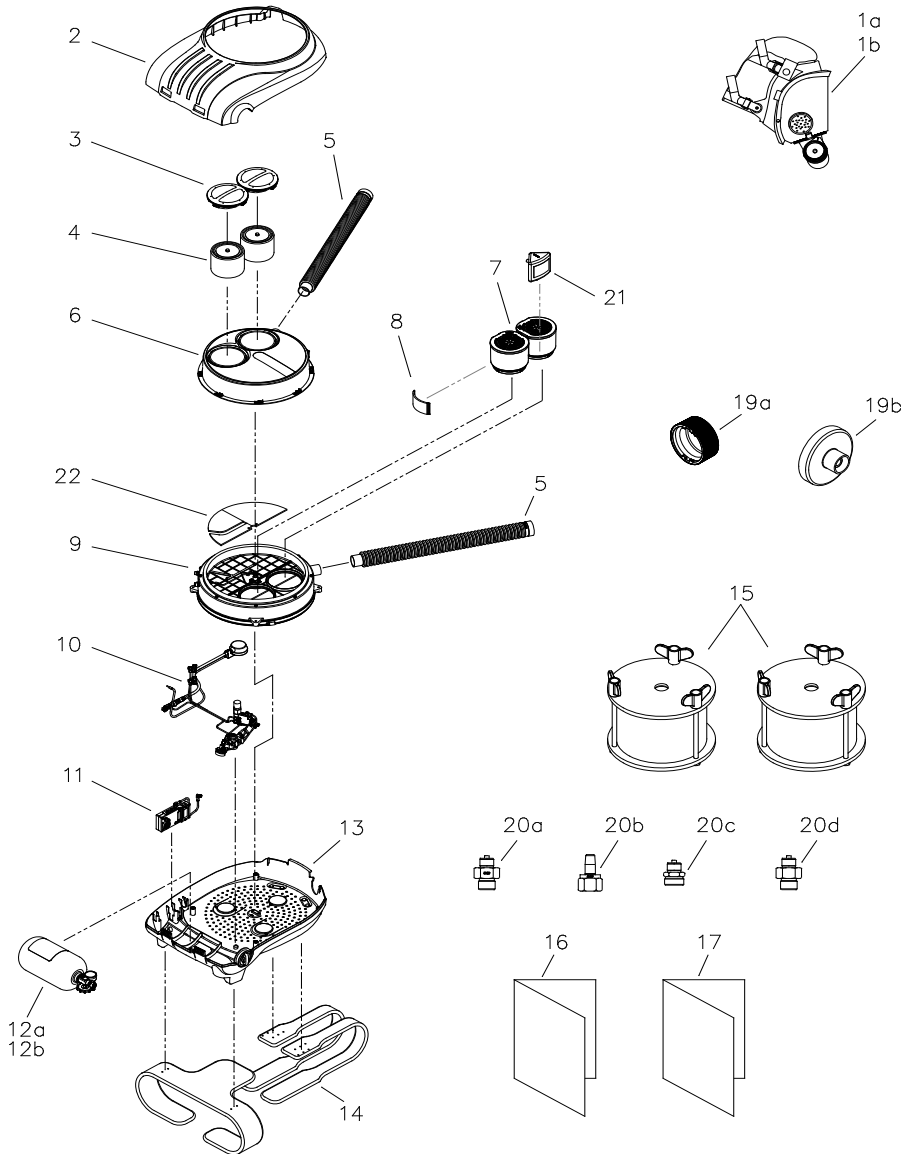

1 Cons. No.	2 Designation	1 Cons. No.	2 Designation
2	Upper Housing Assembly	14	Harness Assembly
3	Coolant Lid	15	Ice Canister Freeze Form
4	Ice Canister	19	Facemask Storage Plug
5	Breathing Hose	21	PCM Heat Exchanger
12	O2 Cylinder	22	Moisture Absorbent Pad Set
13	Lower Housing Assembly		

Lower Housing Assembly

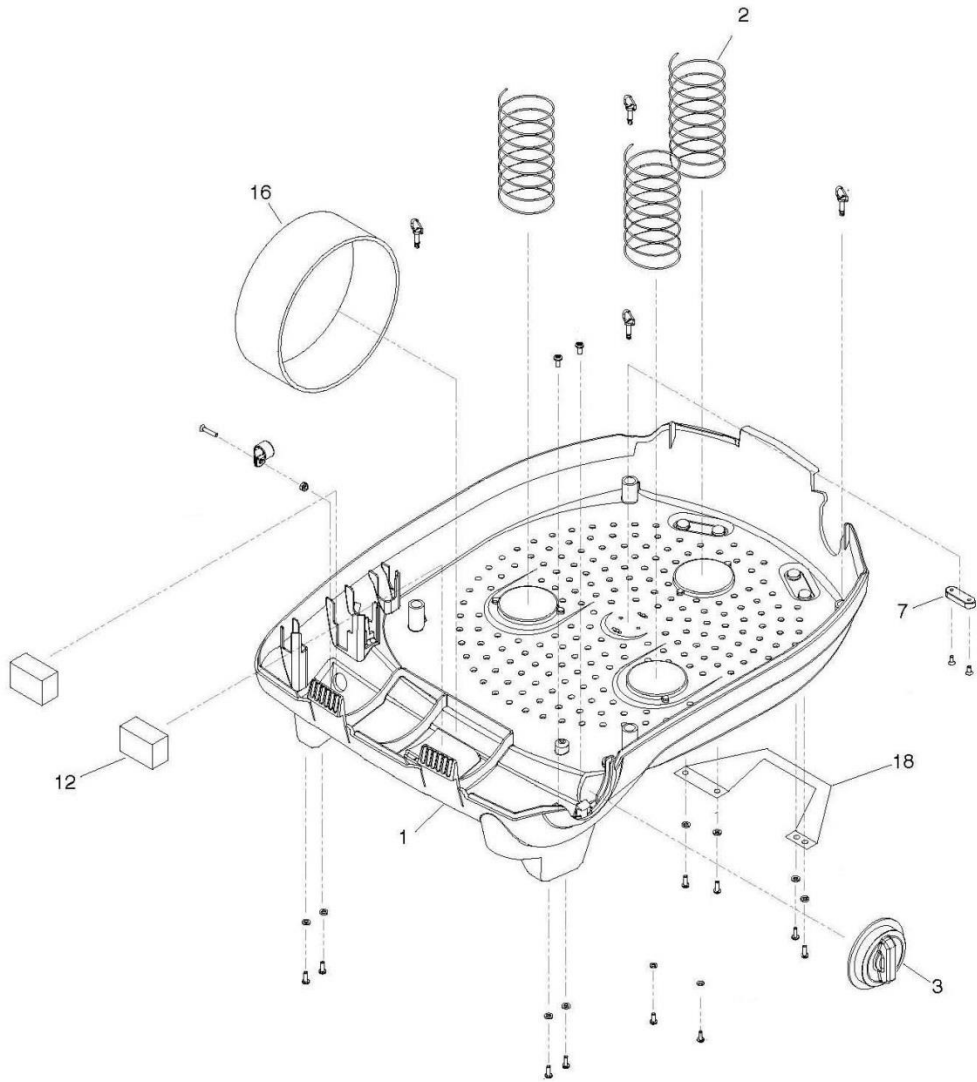

1 Cons. No.	2 Designation	1 Cons. No.	2 Designation
1	Lower Housing Shell	12	Latch Foam Pad
2	Diaphragm Springs	16	Oxygen Cylinder Hold-Down Strap
3	External Oxygen Knob	18	Carrying Handle
7	Vent Spacer		

Pneumatic Assembly

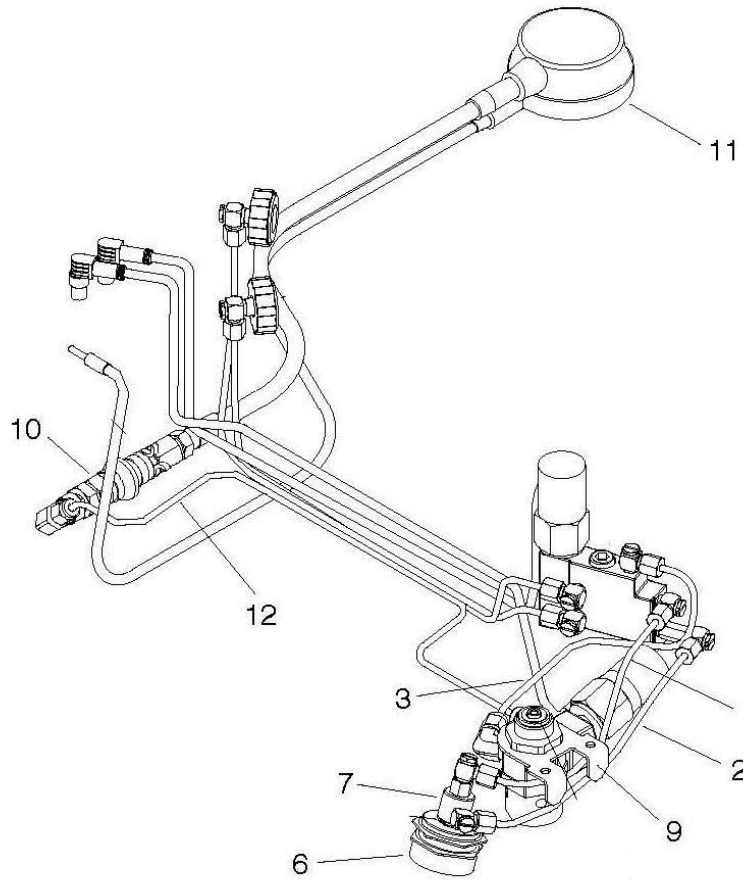

1 Cons. No.	2 Designation	1 Cons. No.	2 Designation
1	Bypass Feed Tube	9	Oxygen Regulator Assembly
2	Bypass Return Tube	10	Remote Gauge Shut Off Assembly
3	Oxygen Feed Tube	11	Remote Gauge Assembly
6	Bypass Valve Push Button	12	Remote Gauge Feed Tube Assembly
7	Bypass Valve		

Manifold Assembly

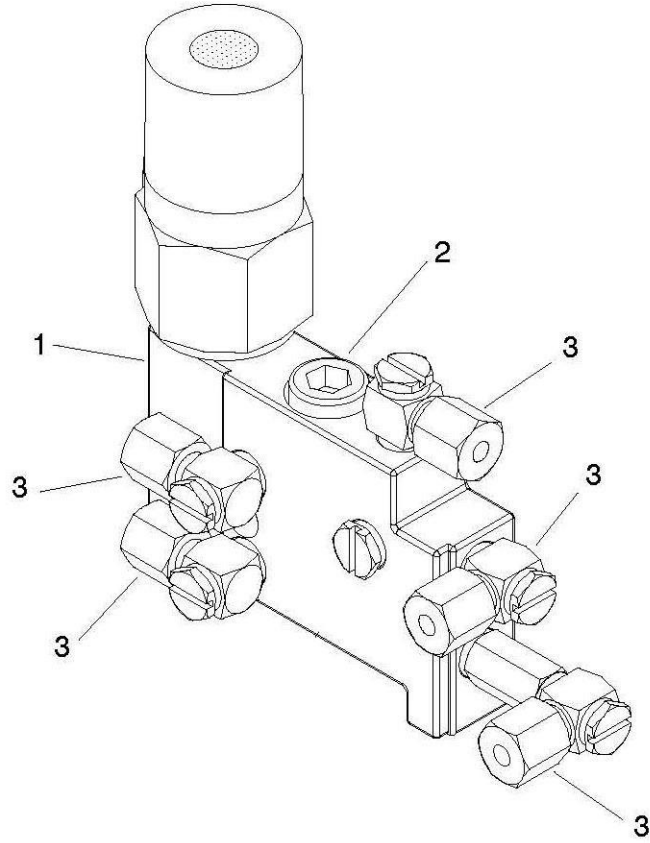

1 Cons. No.	2 Designation	1 Cons. No.	2 Designation
1	Manifold Block w/ Pressure Switch	3	Swivel Elbow Fitting
2	Constant Add Flow Restrictor Assembly		

Center Section Assembly

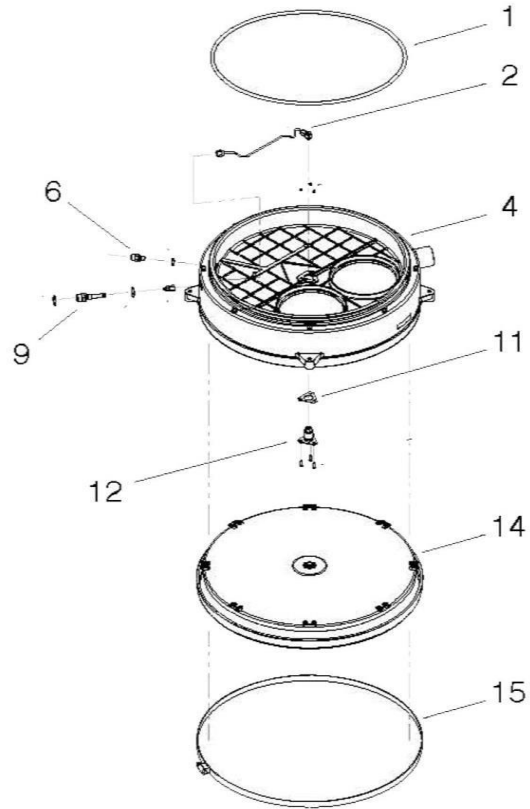

1 Cons. No.	2 Designation	1 Cons. No.	2 Designation
1	Lid O-Ring	11	Demand Valve Gasket
2	Demand Feed Tube	12	Demand Valve Assembly
4	Center Section Body Assembly	14	Flexible Diaphragm
6	Constant Add Fitting	15	Diaphragm Clamp
9	Demand Add Fitting		

Center Section Lid Assembly

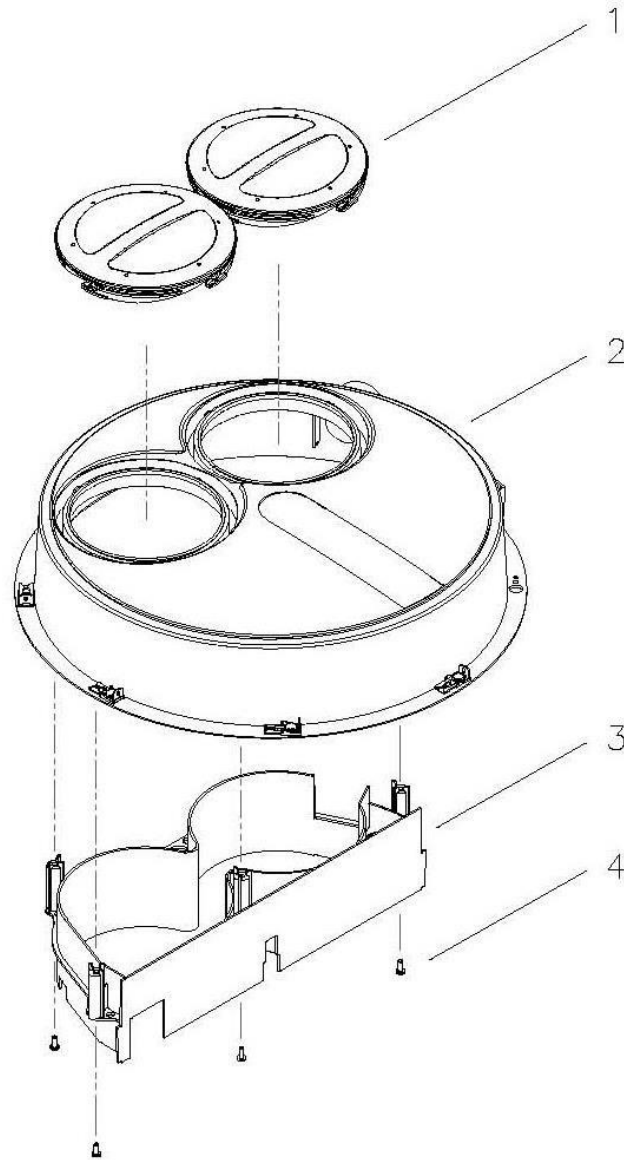

1 Cons. No.	2 Designation	1 Cons. No.	2 Designation
1	Coolant Lid	3	Flow Baffle
2	Center Section Lid	4	Self-Tapping Screws

Diaphragm Assembly

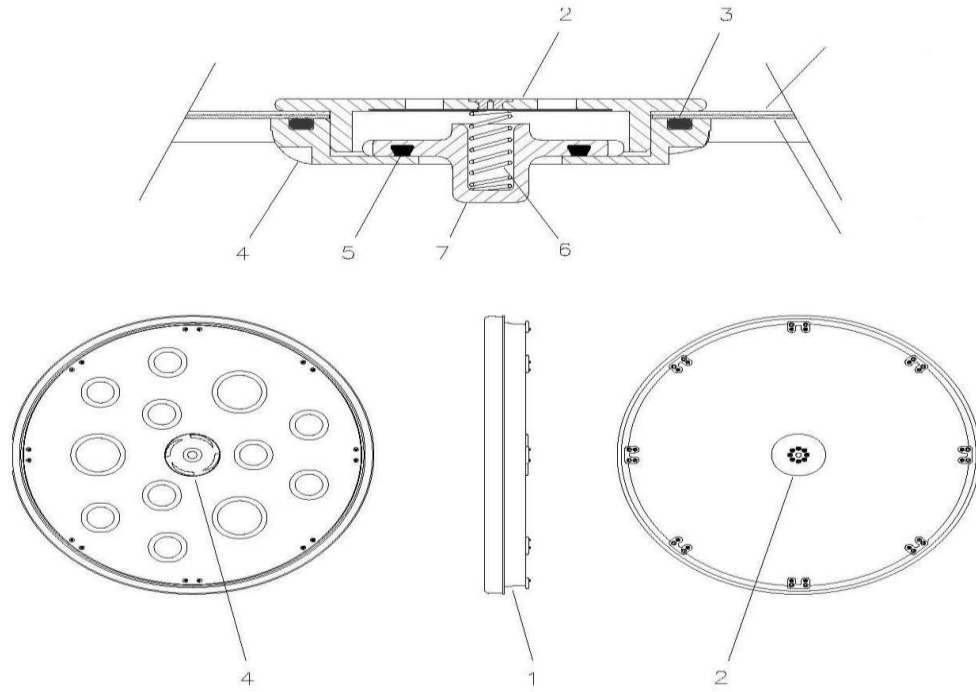

1 Cons. No.	2 Designation	1 Cons. No.	2 Designation
1	Flexible Diaphragm	5	Vent Seat O-Ring
2	Vent Cap	6	Vent Valve Spring
3	Vent Body O-Ring	7	Vent Valve Seat
4	Vent Body		

Breathing Hose

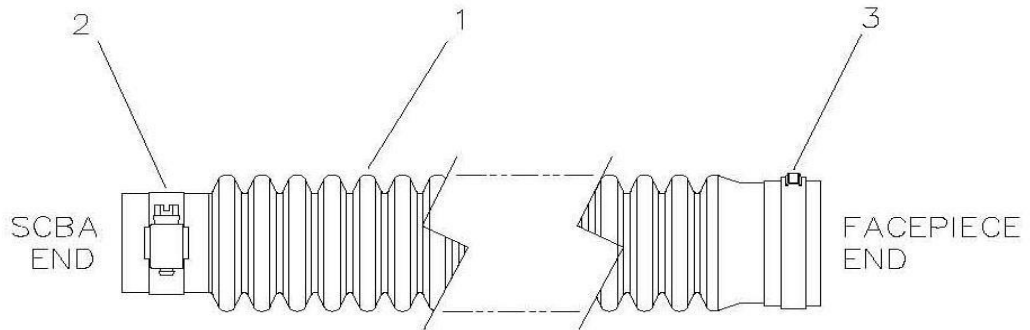

1 Cons. No.	2 Designation	1 Cons. No.	2 Designation
1	Breathing Hose	3	Stepless Ear Clamp
2	Worm Gear Hose Clamp		

Ice Canister Freeze Form

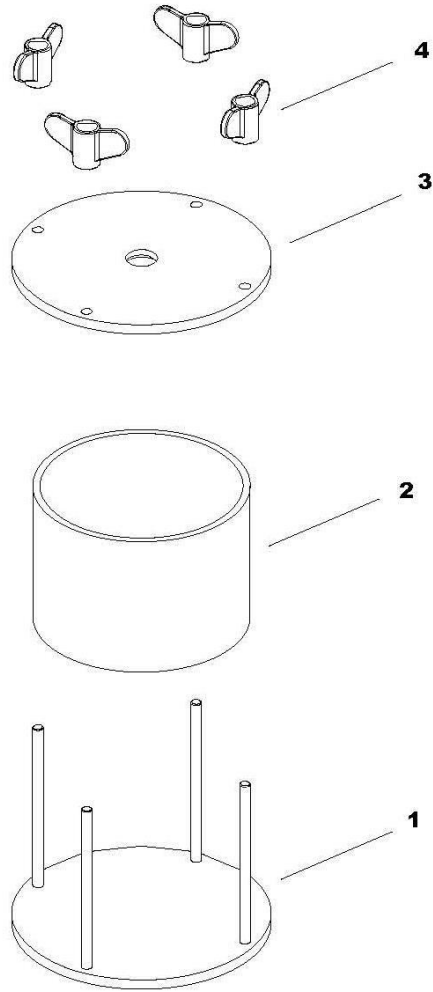

1 Cons. No.	2 Designation	1 Cons. No.	2 Designation
1	Base Assembly	3	Top Plate
2	Freeze Tube	4	Wing Nut

Oxygen Cylinder Assembly

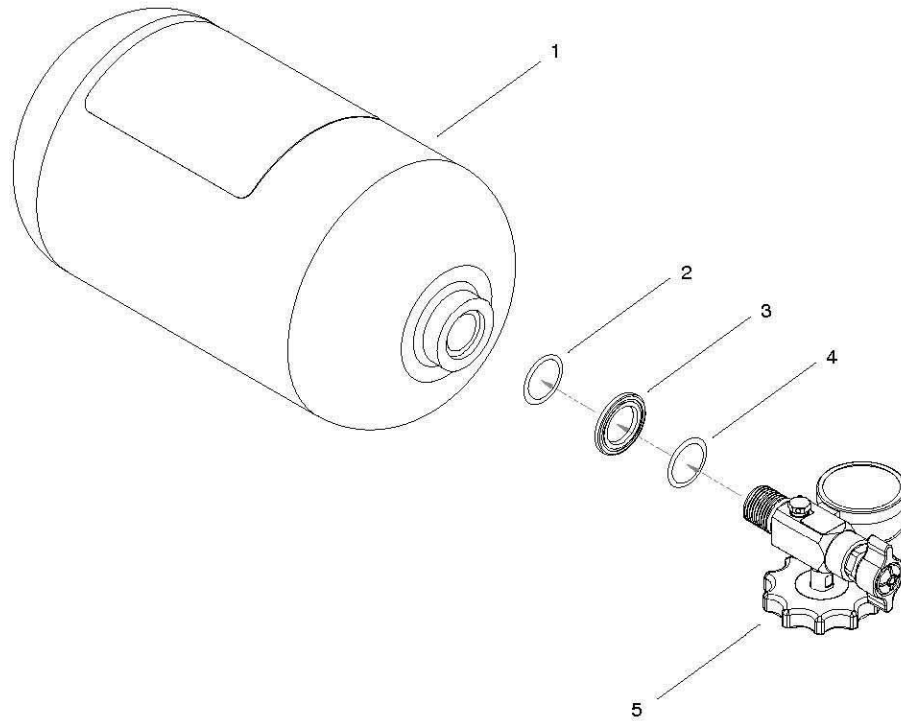

1 Cons. No.	2 Designation	1 Cons. No.	2 Designation
1	Green Cylinder	4	Interior O-Ring
2	Exterior O-Ring	5	Valve Assembly
3	Valve Collar		

RMS Monitoring System

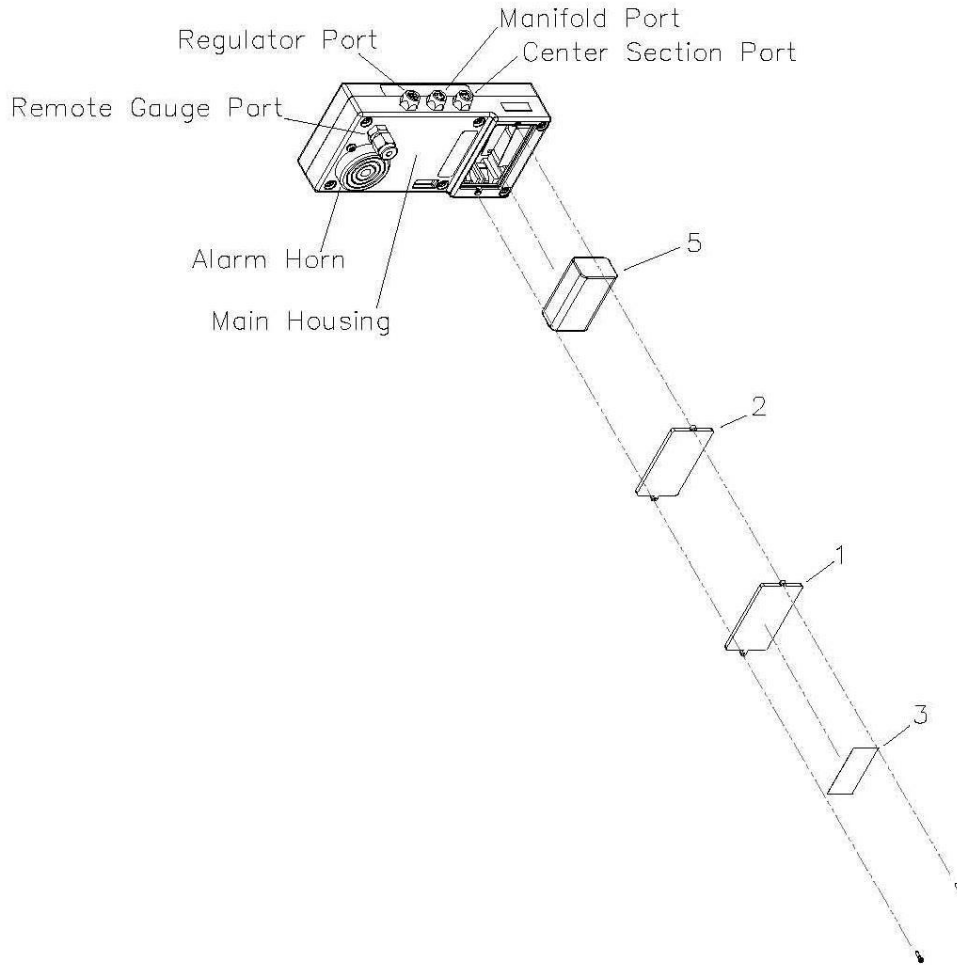

1 Cons. No.	2 Designation	1 Cons. No.	2 Designation
1	Battery Door	3	Battery Door Warning Label
2	Battery Door Gasket	5	9Vdc Battery

Facemask Assembly

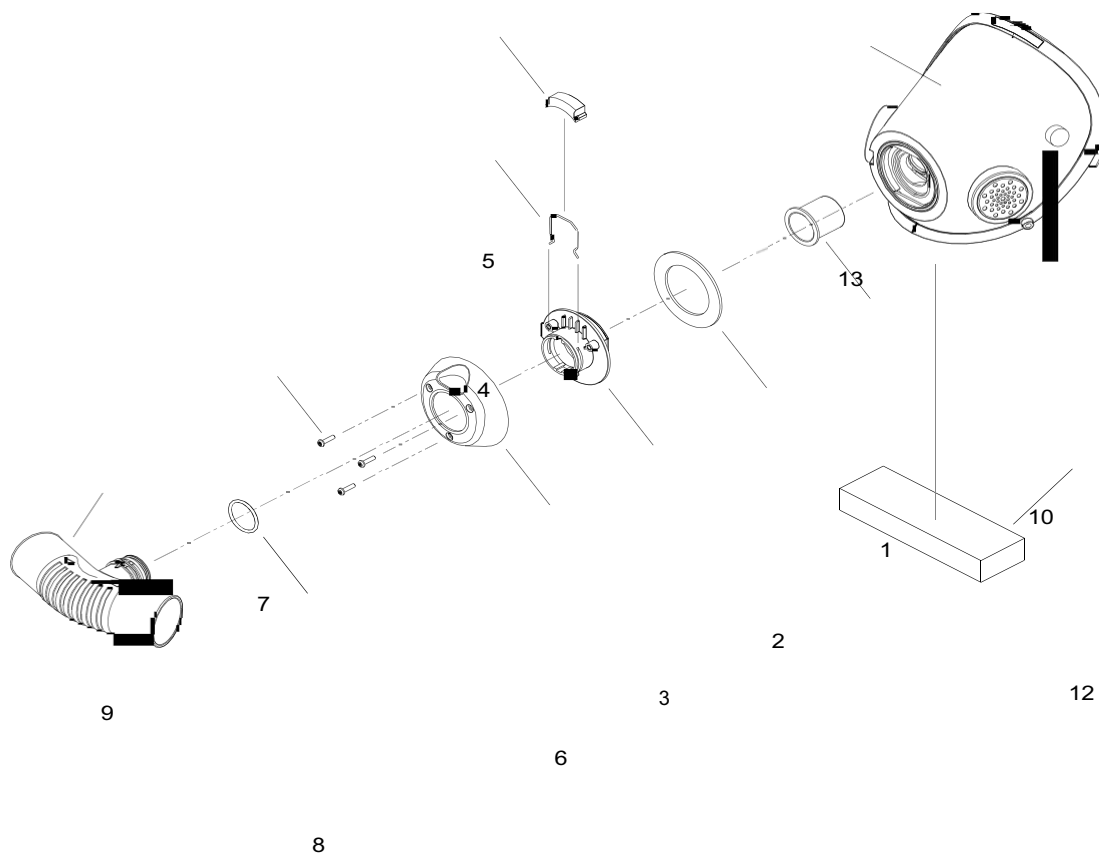

SS

1 Cons. No.	2 Designation	1 Cons. No.	2 Designation
1	Interface Tube	7	Locking Pan Head Screw
2	Interface Gasket	8	Hose Adapter O-Ring
3	Interface Fitting	9	AV3500 Hose Adapter
4	Clip	10	Facemask Magnetic Wiper
5	Button	12	Chin Condensation Pad
6	Cowling	13	Lens

Tool Kit

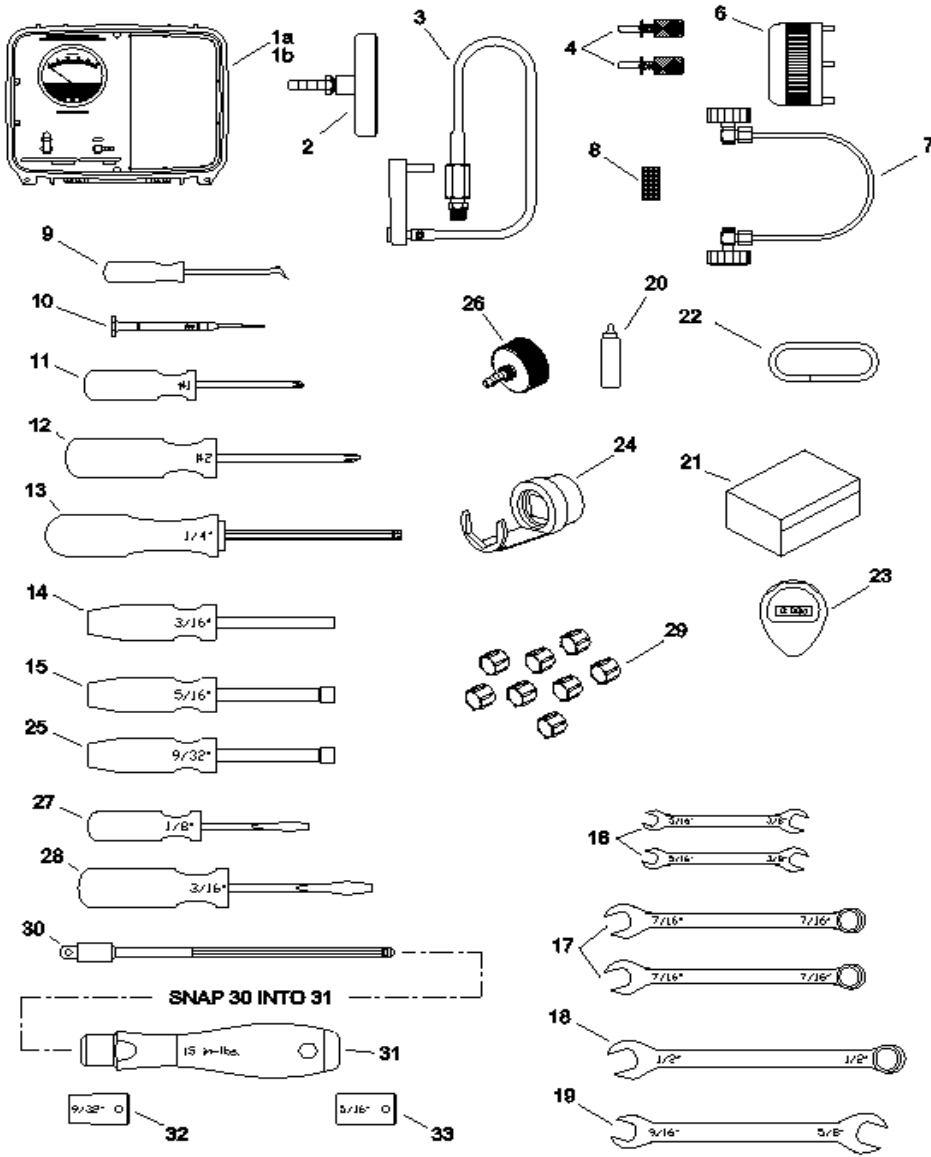

1 Cons. No.	2 Designation	1 Cons. No.	2 Designation
1	Case Assembly	7	Center Section Pneumatic Plug
26	Leak Check Adapter Fitting	9	Combination Pick Tool
3	Flow Test Fixture	13	1/4 - Inch Hex Driver
4	Test Key	20	Leak Detection Fluid
6	Vent Valve Wrench	22	3/8 - Inch OD Rubber Tubing