

Statement

Welcome, thanks for your team coming to help. Your team is located in the first line of crosscuts on the 1st right panel. Presently, airflow is traveling right to left across this line. This panel is four crosscuts deep and was driven for a new intake airshaft. Last night a five man crew entered the panel to clean around the new shaft bottom which is located in the #3 face. Around 2am this morning the crew leader called out and reported that the power had knocked on the permanent sled pump located in the #1 entry on the panel and water was starting to build up. No other communication has been made with the miners. The tracking system last showed the miners on the 1st right panel. The mine is known for bad roof, water, and methane. All other areas of the mine have been made and can be used for ventilation. At this time the backup team is repairing the damaged power cable on the surface for the permanent sled pump that is located on the panel and will not be available to assist with any other working of the problem.

Written Instructions

- (1) Account for all missing miners
- (2) Bring all live miners back to the 1st line to be dropped off.
- (3) The exhaust fan cannot be stopped or reversed
- (4) The map is up-to-date
- (5) The permanent sled pump or suction line cannot be removed from the #1 entry
- (6) The pump switch is off at this time and must be turned on by the team before requesting the power to be put in on the sled pump. After the switch is turned on the team can request power to be turned on and off through the command center's briefing officer or command center attendant.
- (7) The briefing officer or command center attendant must verbally request power to be put in or taken out on the sled pump through Mine superintendent
- (8) Your team has 90 minutes to complete the problem.
- (9) Good luck

Vent before turning pump on

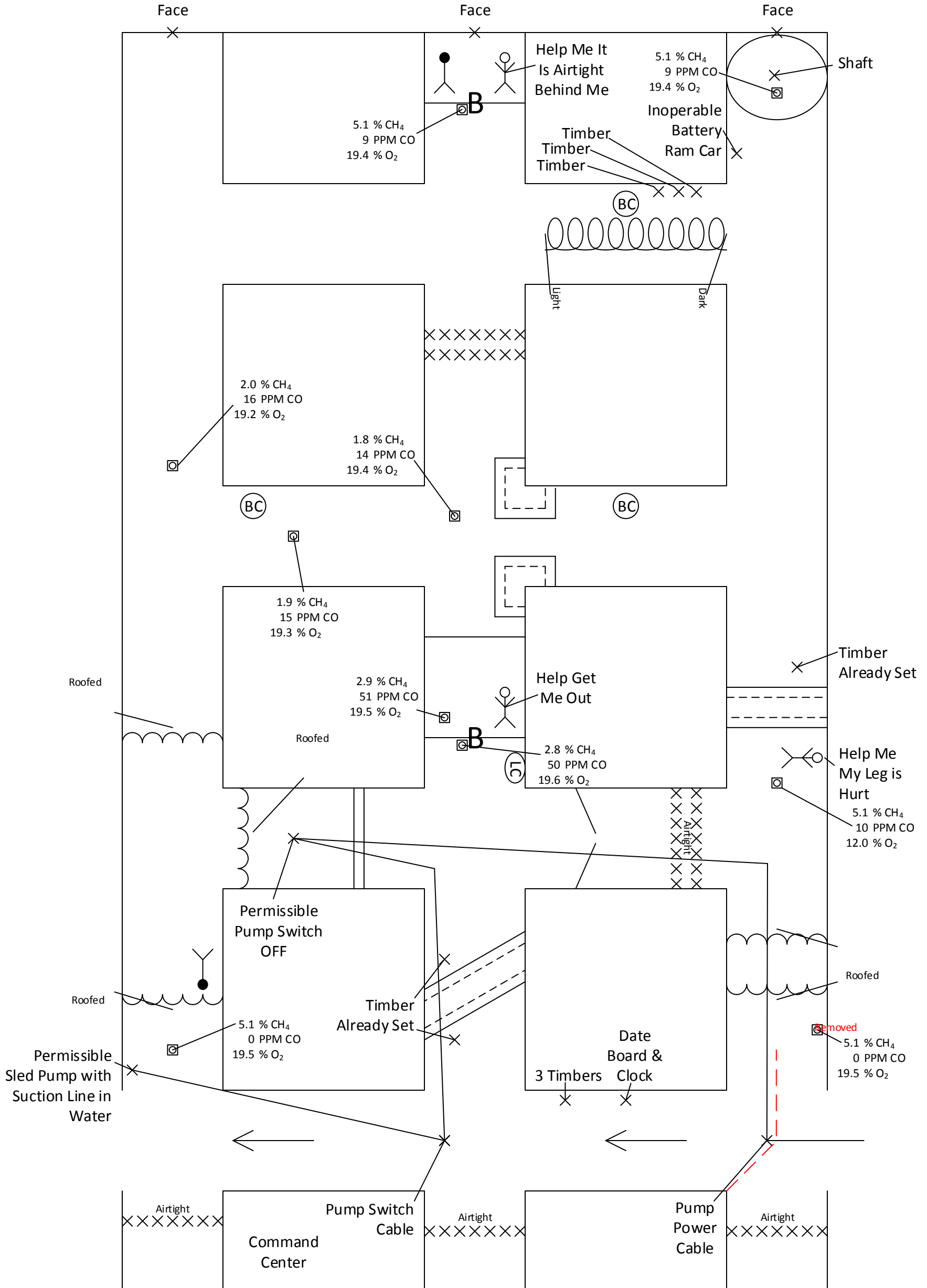

1st vent change to clear barricade

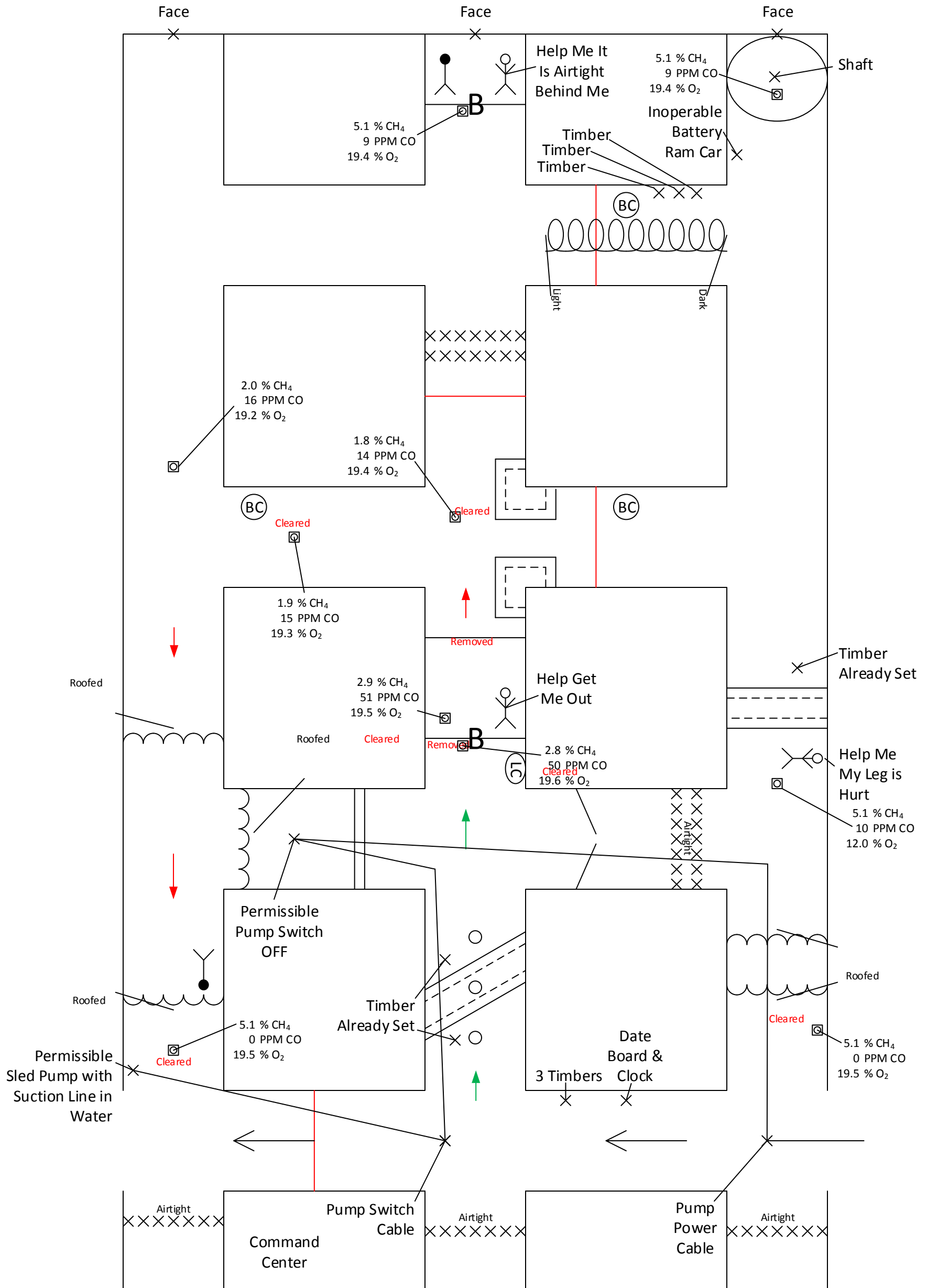

2nd vent change to clear barricade

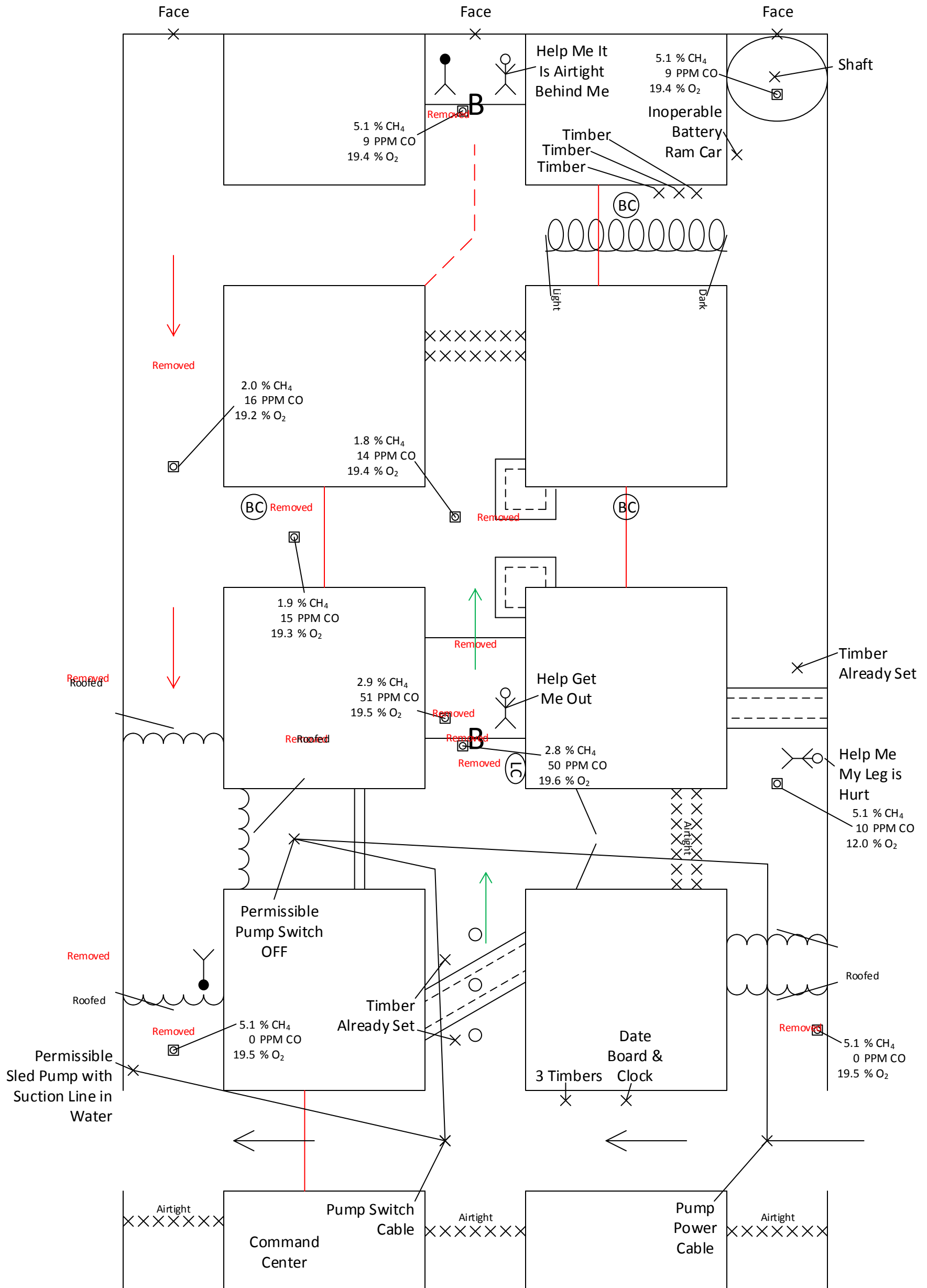

Extend of Gases

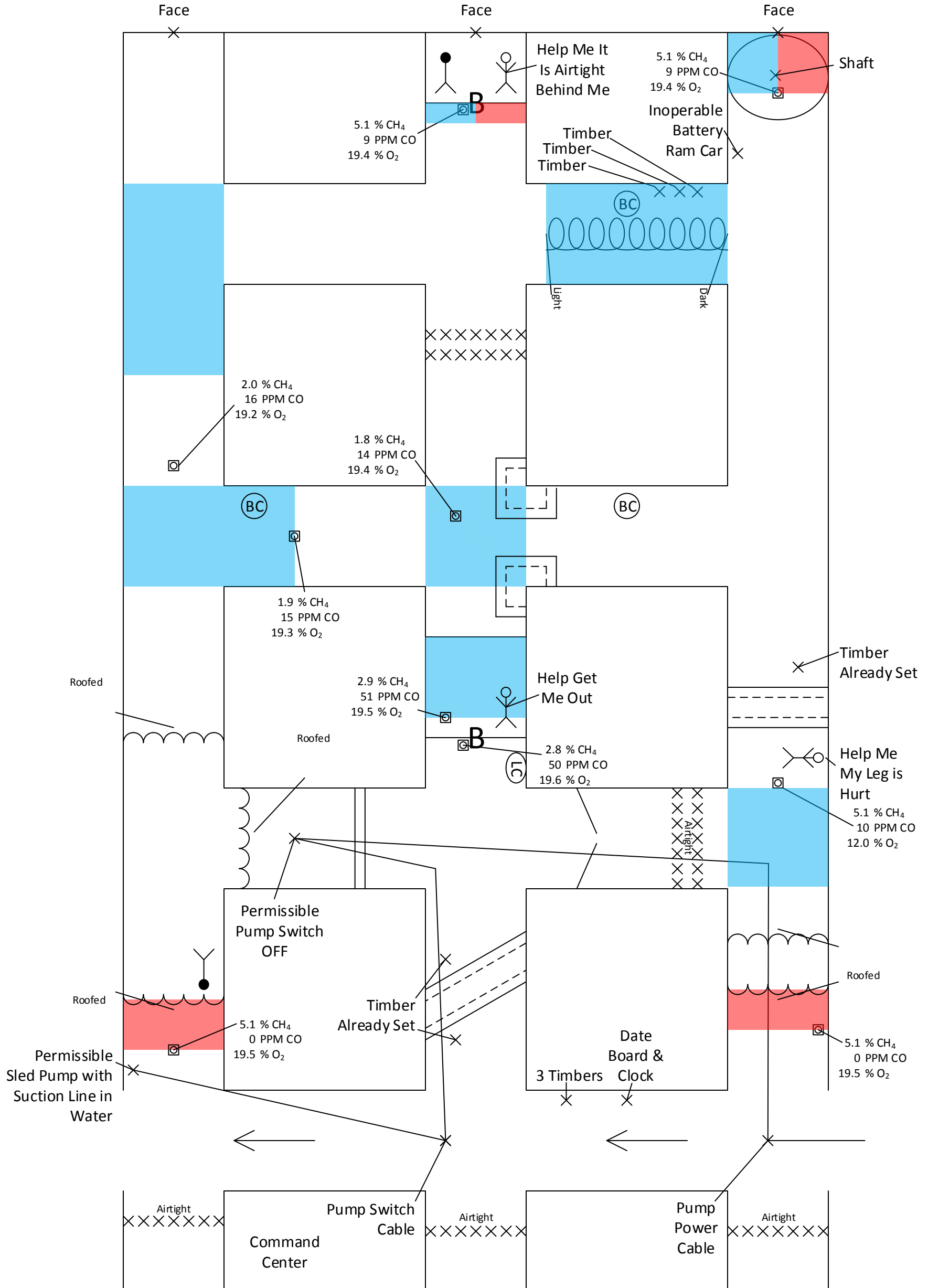

Final Vent Map

Team Number _____

Captain/Designee _____

Did teams explore to shaft in #3 entry
____ YES ____ NO

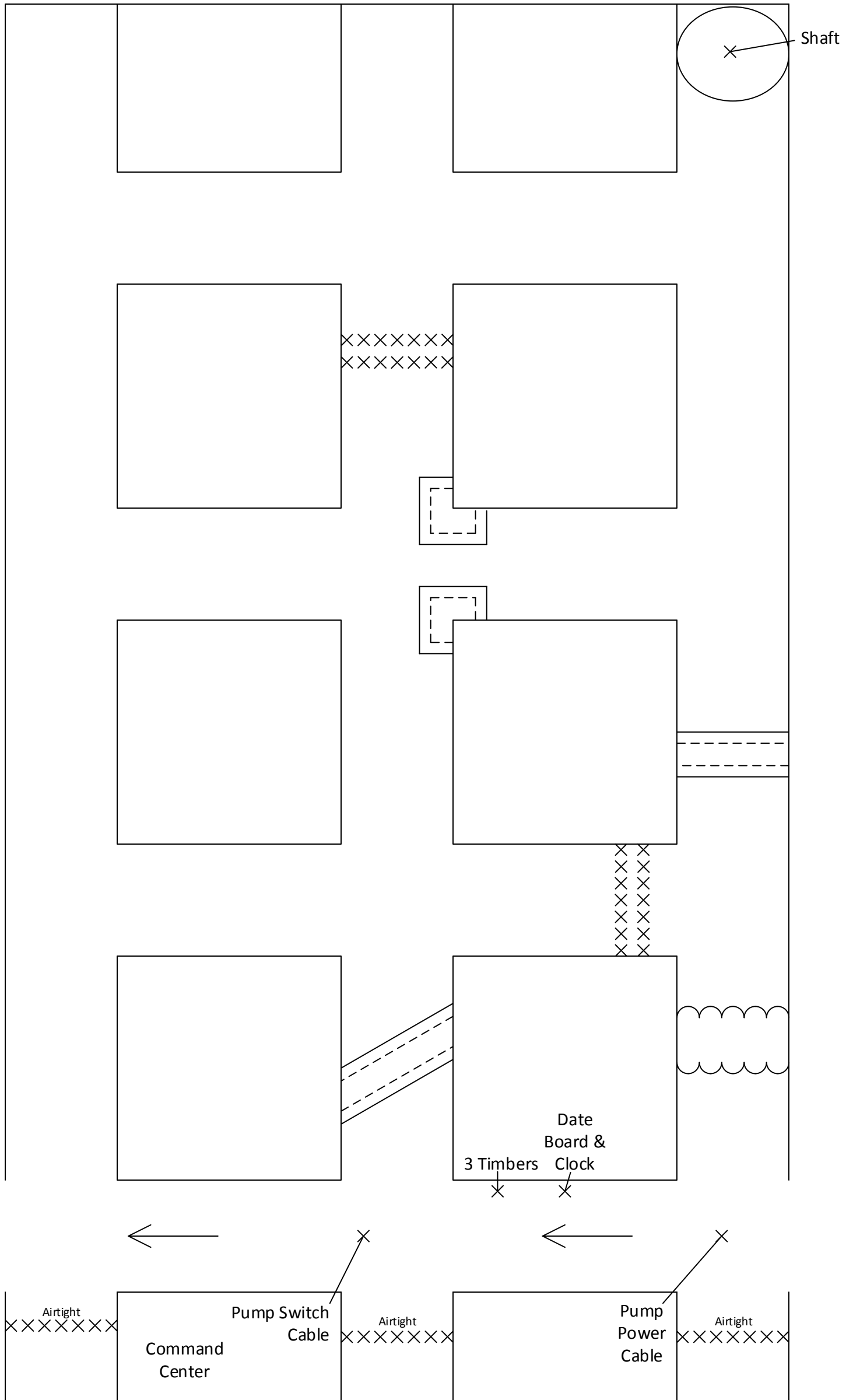

Team Stops

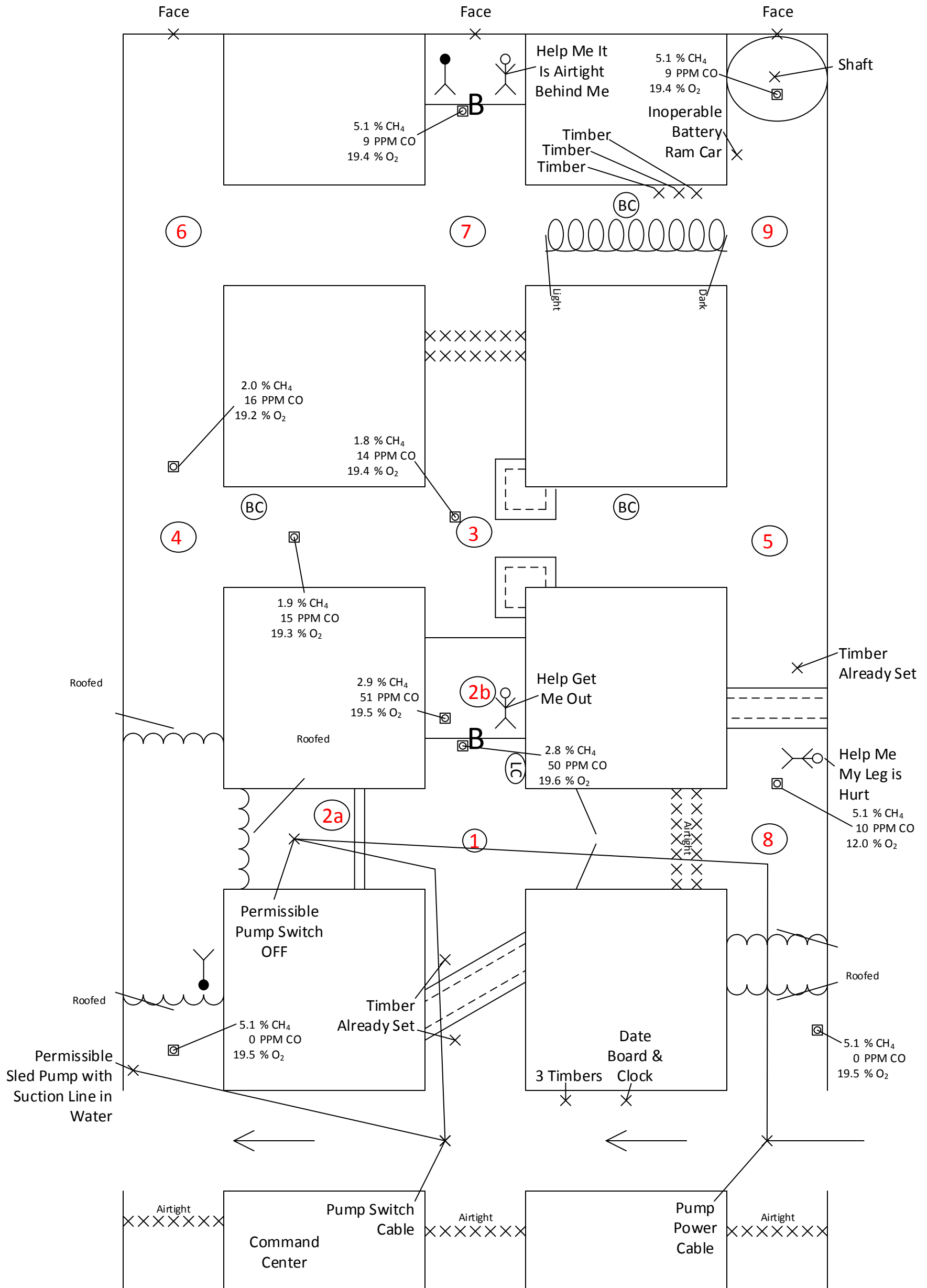

Patient statement behind first Barricade

Help Get Me Out

**Patient statement behind
second barricade**

**Help Me it is airtight
behind Me**

**Patient statement behind
unsafe roof**

**Help Me
My leg is hurt**