

Farmington 2012

Hard work it worth it

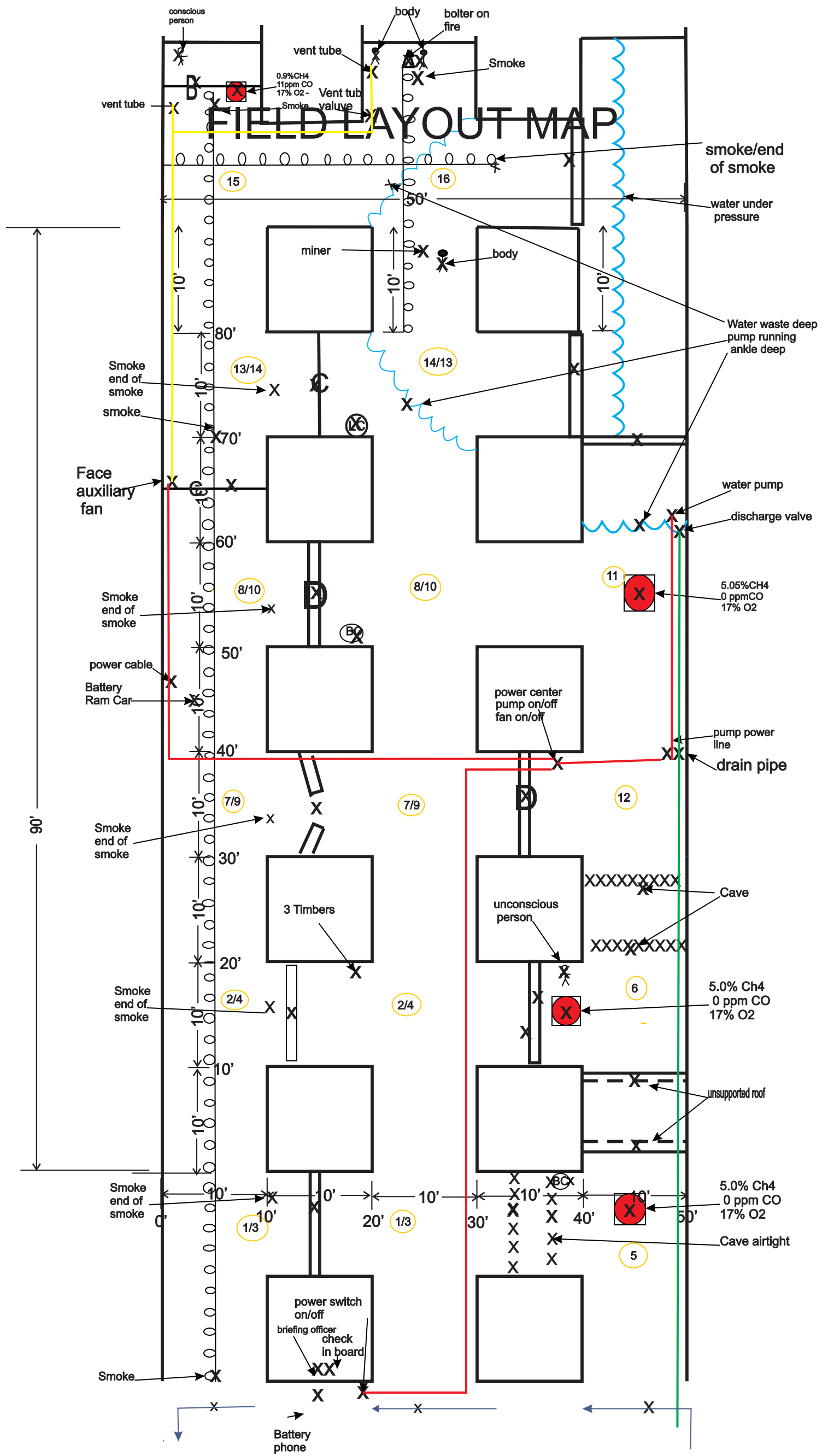

Field Problem #1



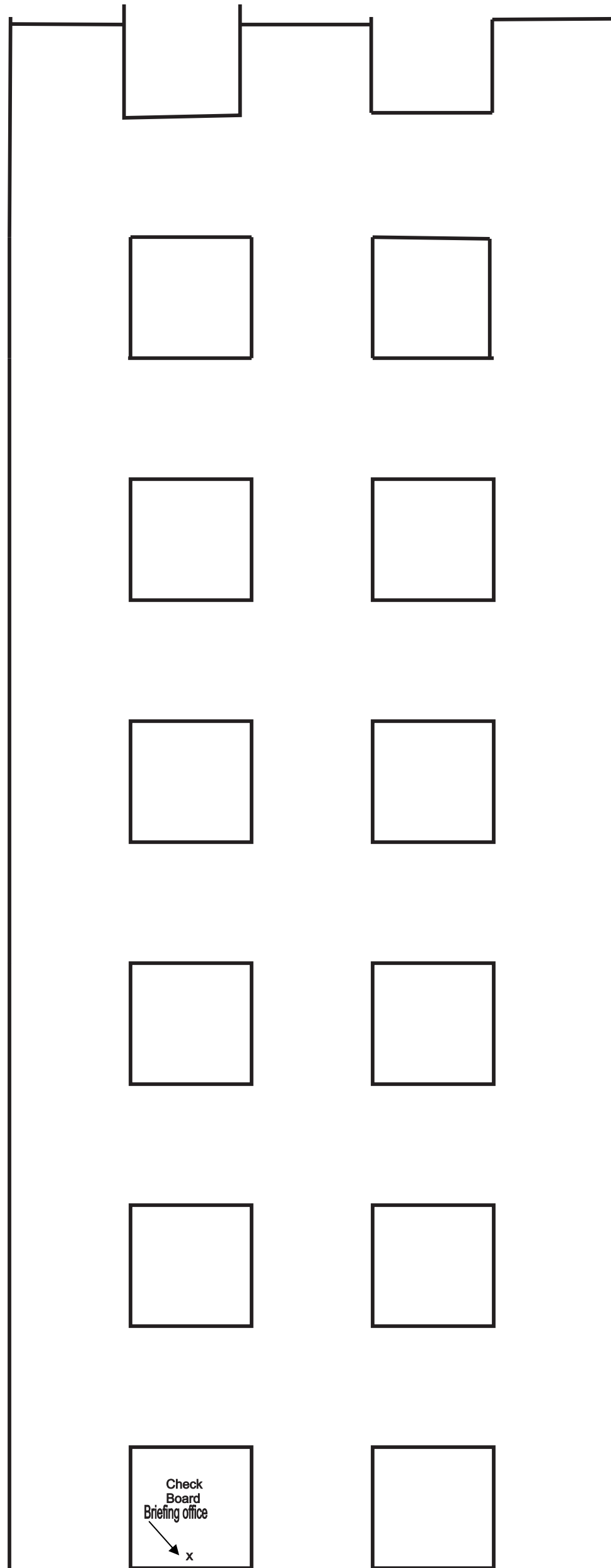

BRIEFING OFFICE MAP - SCALE 1" = 10'

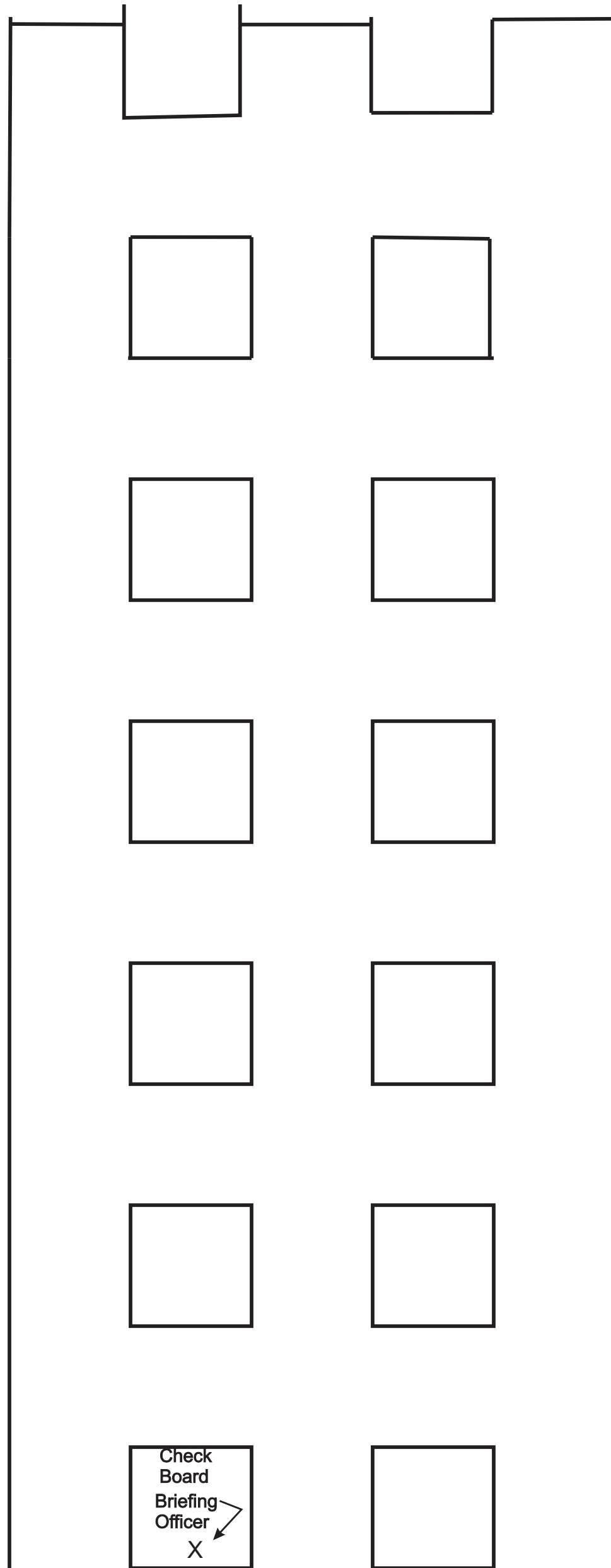

TEAM MAP - SCALE 1" = 10'

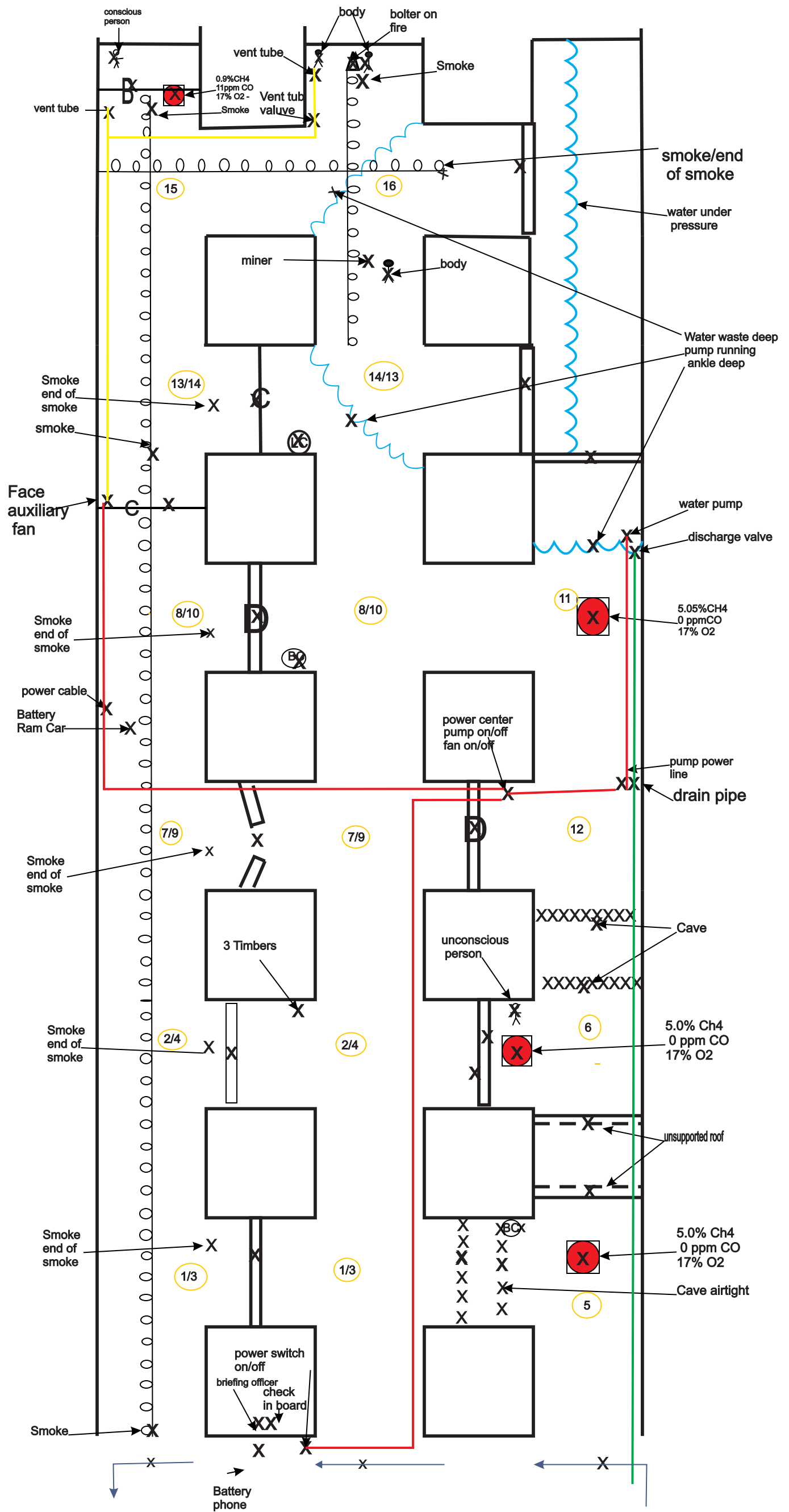

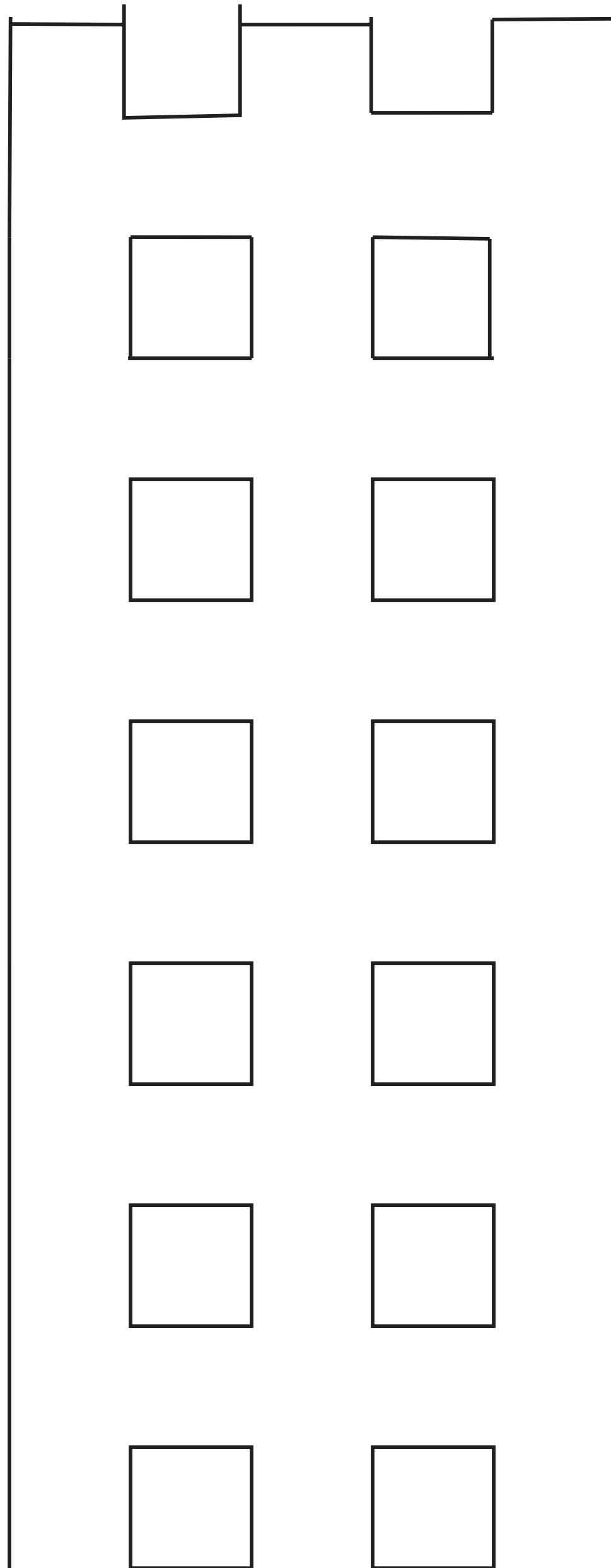

JUDGES MAP

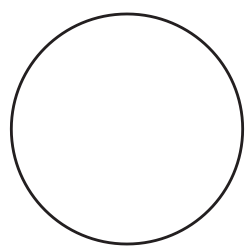
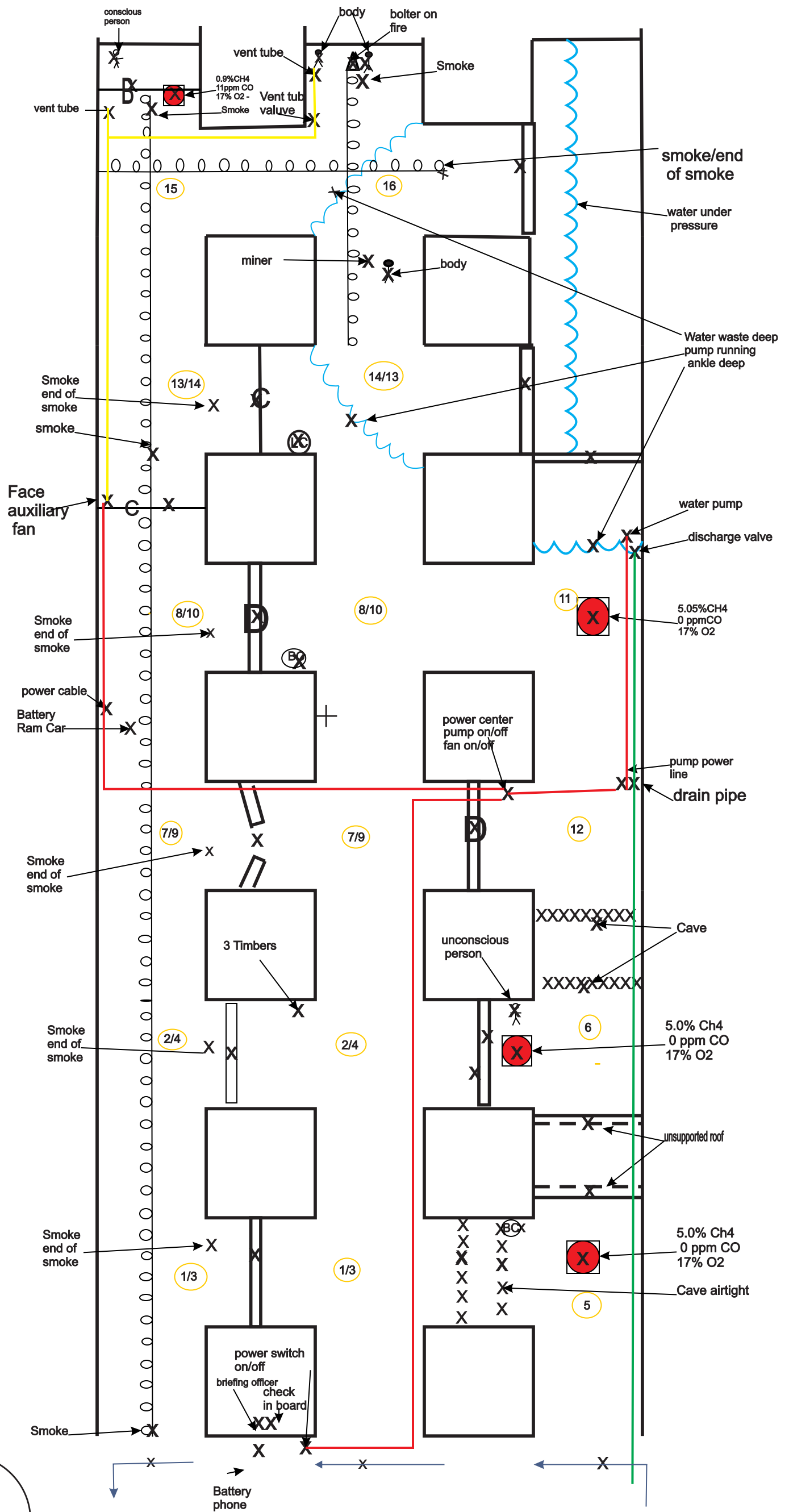

6' Radius Circle

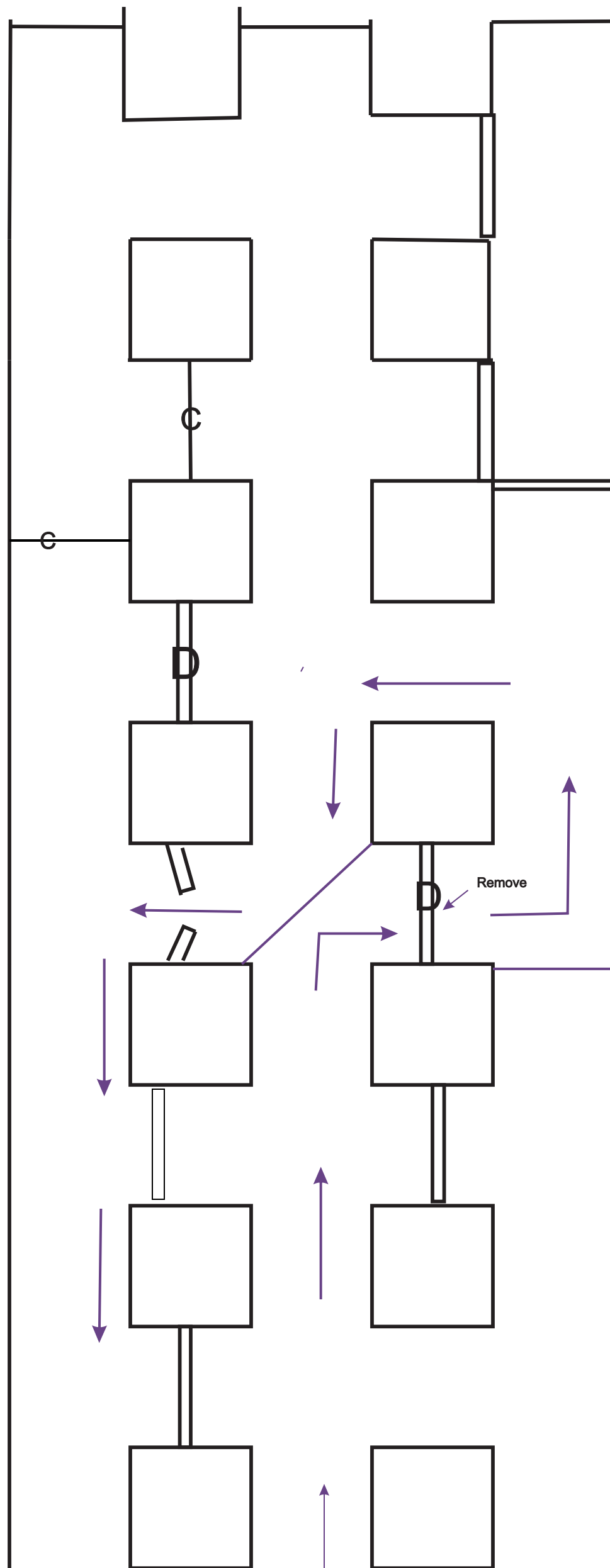

STEP 1 VENTILATION

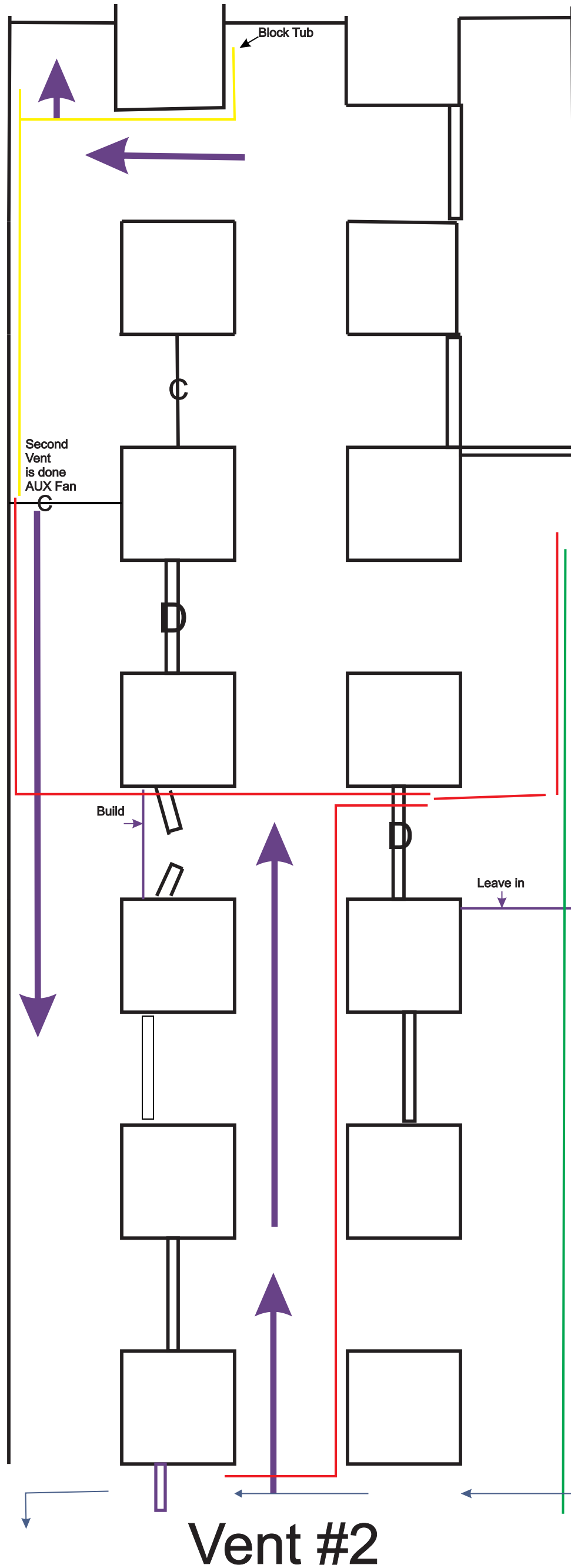

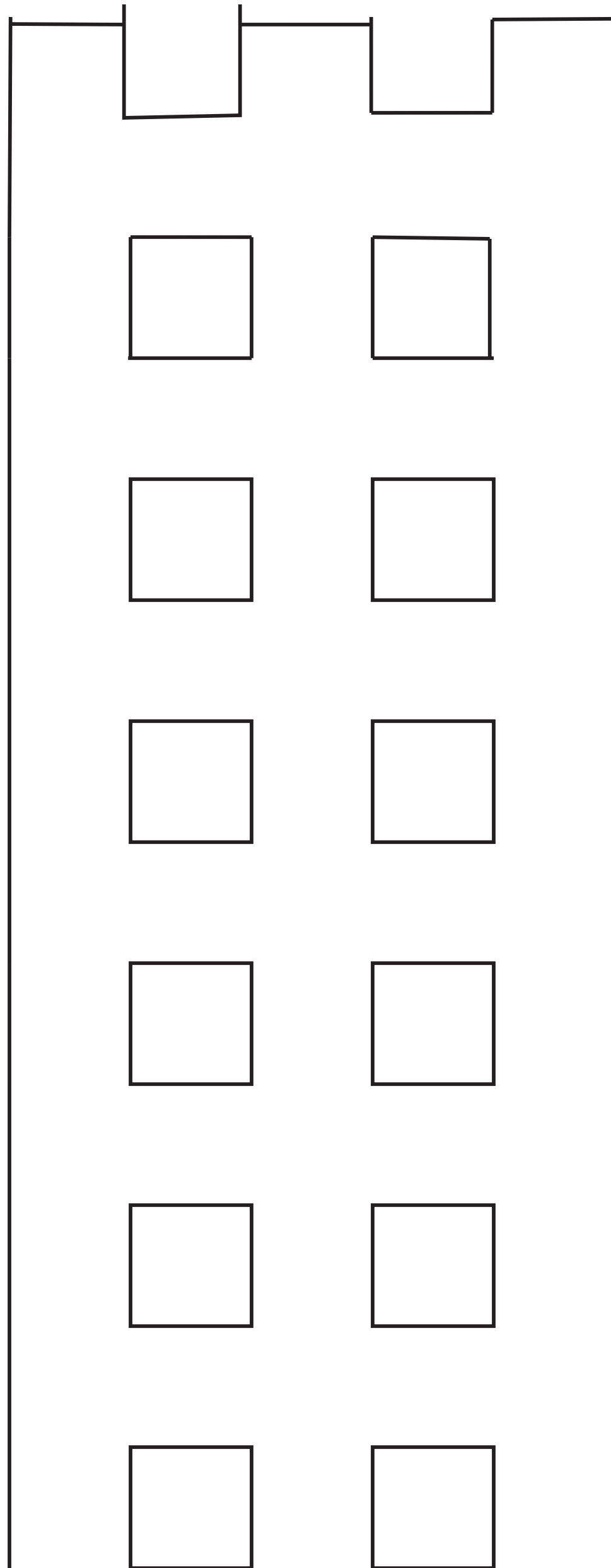

JUDGES VENT/FINAL MAP

2012 Colorado Mine Rescue Association
Four Corners Mine Rescue Contest
Farmington, NM

MR Problem No. 1 changes

The 3 gas placards with methane on them were changed.

- Entry 1 XC1 5%CH₄, 0ppmCO, 12%O₂
- Entry 1 XC2 5%CH₄, 0ppmCO, 12%O₂
- Entry 1 XC4 4.9%CH₄, 0ppmCO, 17%O₂